

PEROVSKITES - AN UNIQUE CLASS OF MATERIALS

B. Viswanathan

July 26, 2024

Contents

1	INTRODUCTION	7
1.1	Materials Science An emerging Discipline	7
1.2	Properties of Perovskites	13
1.3	Applications	13
1.4	Perspectives	14
1.5	Conclusion	16
2	STRUCTURE OF PEROVSKITES	19
2.1	Introduction-The Perovskite Structure	19
2.2	Cubic Close Packing (CCP)	20
2.3	Voids in crystal: Octahedral (O) and Tetrahedral (T_+ and T_-)	20
2.4	Location of tetrahedral and octahedral sites in an fcc/ccp unit cell	21
2.5	ReO_3 Structure	22
2.6	The Perovskite Structure	22
2.7	suggested Reading Resources	23
2.8	Distortion in Perovskite Structure	23
2.9	Structure of Hybrid Organic-Inorganic Perovskite (HOIP)	25
2.10	Suggested Reading Resources	26
2.11	A_2BO_4 -Layered Perovskite:	28
2.12	Double Perovskite, $A_2BB'O_6$	29
2.13	References	29
3	SPECIAL APPLICATIONS OF PEROVSKITES	35
3.1	Perovskites in Magnetic Devices	35
3.2	Electronic Structure of Perovskites	35
3.3	Perovskites in Magnetocaloric Effect Based Magnetic Refrigerators	36
3.4	Perovskites in Spintronics	37
3.5	Perovskites in Data Storage System	38
3.6	References	38
4	HYBRID ORGANIC INORGANIC PEROVSKITES - AN INTRODUCTION	41
4.1	Introduction	41
4.2	References	43
5	PERSPECTIVES ON PEROVSKITES	47
5.1	Perovskite Solar Cells	47

6	HYBRID PEROVSKITES - SOLAR CELLS	53
6.1	Introduction	53
6.2	Hole Transport Layer:	56
6.3	Electron Transport Layer:	56
6.4	Opto-Electronic Property	59
6.5	Factors Influencing the Performance of Perovskite Materials	60
6.5.1	Solar Radiation	60
6.5.2	Influence of Thickness	60
6.5.3	Influence of Defect Density	60
6.5.4	Influence of Temperature	61
6.5.5	Influence of Moisture Content and Oxygen	61
6.5.6	Influence of Other Effects	62
6.6	The Challenges	63
7	PROPERTIES OF PEROVSKITES	67
7.1	Introduction	67
7.2	phase Transitions in Perovskites	67
7.3	Piezoelectricity	68
7.4	Pyroelectricity	69
7.5	Ferroelectricity	70
7.6	Superconductivity	70
7.7	Multiferroicity	71
7.8	Colossal magnetoresistance (CMR)	72
7.9	Other Properties	73
7.10	Thin Film Capacitors	74
7.11	Laser and Light-Emitting Diodes	74
7.11.1	Laser (Light Amplification by Stimulated Emission of Radiation)	75
7.11.2	Light-emitting diodes (LEDs).	75
7.12	Memory Devices	75
7.13	References	76
8	Perovskite – A catalyst for Solar Hydrogen Production	77
8.1	Introduction	77
8.2	Principle of Water Decomposition	78
8.3	References	79
9	Sensing Applications of Perovskites	81
9.1	Introduction	81
9.2	Sensors Based on Perovskites	81
9.2.1	Chemiresistive Gas Sensors	81
9.3	Optical sensors using halide perovskites	82
9.3.1	Gas optical-sensor	82
9.4	Optical sensors for the chemicals in the solution	83
9.4.1	Ionic sensing	83
9.5	Photoelectrochemical sensor	83
9.6	General Remarks	84
9.7	References	84

<i>CONTENTS</i>	5
10 Preparative Methods for Perovskites	87
10.1 Introduction	87
10.2 Solid State Reaction	87
10.3 Sol-gel auto combustion method	88
10.4 Co-precipitation method	89
10.5 Hydrothermal synthesis	89
10.6 Pechini Method	89
10.7 Microwave Synthesis	90
10.8 References	90
11 In Retrospect	93
11.1 Introduction	93
11.2 Future Prospects	94
11.3 Reference	96
12 Appendix	97
13 INDEX	107

PREFACE

In Science education today, Materials occupy a unique place. Identifying appropriate material is an essential step for many detecting and monitoring devices. These devices are an integral part of human life today. Though in the last five decades or so, Materials Science has assumed an important place in our educational curriculum, the enormous properties exhibited by a set of materials like Perovskites are always fascinating and interesting.

The science and technology of Materials have been undergoing tremendous change in the last 50 years and many aspects of these systems are still under investigation all over the world. These materials under the influence of external field like electric, magnetic or combination of fields exhibit various phenomena like ordering arrangements in magnetic spins and other attended physical variables and these can manifest in an appropriate signal which can be amplified and used for detection and monitoring.

The field of Material Science is vast and boundless. Therefore, to make it easy to comprehend, in this short monograph we have considered a class of important material namely Perovskites. Even here, we have to restrict ourselves on certain aspects of these materials to make it within certain number of pages and hence only the essential features of these materials are dealt with in this exercise.

Perovskites constitute possibly one of the fascinating classes of materials exhibiting diverse properties anywhere between ferroelectricity and superconductivity. Oxides and fluorides are the most commonly found materials of perovskite structure with the general composition ABX_3 . A variety of other structures, especially in complex metal oxides, contain the perovskite unit. Structure and properties of perovskites constitute an excellent case study of the chemistry and physics of materials and hence this choice.

Every effort has some objective in mind. In formulating this monograph, the objective is to enthuse young generation into the fascinating field of material science and show them the golden opportunities that lay before them. If it in any way to a limited extent, fulfills this objective, one will consider the fulfillment of the objective.

As a typical example, in this exercise, we have chosen Perovskite materials, this does not mean to undermine the importance of other class of materials (optical, electronic, dielectric and so on materials). This class of compounds are chosen for the simple reason that many solid state materials are possible by substitution (partial or whole) at A and B sites in ABX_3 composition representing perovskite structure.

Any shortcomings in this exercise are pointed out, we shall be grateful. Thanks are also due to all those members of National Centre for Catalysis Research at the Indian Institute of Technology, Madras who are and were motivating spirit in this exercise.

B. Viswanathan
July 2024.

Chapter 1

INTRODUCTION

1.1 Materials Science An emerging Discipline

Material Science is the Emerging Discipline in this century, Material Science will dominate the research and application fields due to various reasons, mainly because of their application potential in devices. Materials have been the centre of all human endeavours through all the centuries. In this sense, the ages have also been named after materials such as stone age, bronze age, iron age, and so on and the current time can be called nano-age. The history of materials science is the study of materials of various kinds which are used and employed in the development of society all these days. The development of material science has been the main reason for the culture of the people on this earth. The materials have been the record of the age of the cultures throughout these centuries.

Even though many branches of science have their founding figures, no such single person can be identified as the founding central figure of modern material science. During the second world war, the collaborations of multiple fields of study were needed to produce technological advances which have led to the concept of Material Science and Engineering. After this, the US President Science Advisory Committee (PSAC) came up with the idea of materials as the central factor in the development of space and military technology. Consequent to this, five chosen and major universities in the US were identified as initial centres of research activities in Material Science. This initiative has led to many departments around the world, changing its name to material science. Some new centres have also been formulated in various institutions [1].

Material Science has been revolutionizing life on earth, especially in the last few decades. In every sphere of human activity, new materials have changed life style in terms of time and comfort. Metal oxides are a growing set of materials employed in many industrial products, especially in environmental remediation, medical technology, energy conversion, water treatment and personal care products. These applications it is projected, will increase in the coming days. It is stated that three to four new consumer products are introduced every week, employing these solid-state materials.

The known oxide materials assume various structures. Typical oxide systems are assembled in Table 1. Many of these systems are naturally found. Their properties can be effectively utilized in some of the solid-state devices now in use [2].

Among the various solid-state materials, oxides especially the class under the general name “perovskites” have been occupying a central place. Perovskites (mostly mineral of magnesium, silicon and oxygen, (MgTiO_3)) accounts for half of the total mass of the planet earth, and therefore it is the most available material in this world. Earth mantle is supposed to be made up of various kinds of perovskite structure; nobody has yet taken a sample out of it to prove it.

Table 1.1: Table 1 some of the known Oxide Materials

Name of the structures	Typical examples	Typical uses
Perovskites	CaTiO_3	Solar cells, opto-electronics
Spinel	$\text{Mg}_2\text{AlO}_4, \text{Fe}_3\text{O}_4$	Ferrimagnetism
olivine	$\text{Mg}_2\text{SiO}_4, \text{Fe}_2\text{SiO}_4$	Gemstone
ilmenite	FeTiO_3	Ore for Ti
Fluorite	CaF_2	Fluorescence
Pyrochlore	$(\text{NaCa})_2\text{Nb}_2\text{O}_5\text{F}$	Magnetic property
Garnet	$\text{X}_3\text{Y}_2(\text{SiO})_2$	Magnetic Property
Rutile	TiO_2	semiconductor, Photocatalyst

At high pressures, the silicate mineral olivine transforms into ringwoodite spinel structure, and very high pressure transforms it to perovskite structure [3] as shown: Mg_2SiO_4 (Olivine) \rightarrow SiMg_2O_4 (Spinel) \rightarrow MgSiO_3 (Perovskite) + MgO (Periclase)

Depth (km)	Phase Transformation
Transition Zone	
410	Olivine ($\alpha\text{-(Mg,Fe)}_2\text{SiO}_4$) \leftrightarrow Wadsleyite ($\beta\text{-(Mg,Fe)}_2\text{SiO}_4$)
450	Kyanite (Al_2SiO_5) \leftrightarrow Corundum (Al_2O_3) + Stishovite (SiO_2) (tetr.)
520	Wadsleyite ($\beta\text{-(Mg,Fe)}_2\text{SiO}_4$) \leftrightarrow Ringwoodite ($\gamma\text{-(Mg,Fe)}_2\text{SiO}_4$)
400-600	Pyroxene ($(\text{Mg,Fe)}_2\text{Si}_2\text{O}_6$) \leftrightarrow Majorite ($\text{Mg}_3(\text{MgSi})\text{Si}_3\text{O}_{12}$)
Lower Mantle	
670	Ringwoodite ($\gamma\text{-(Mg,Fe)}_2\text{SiO}_4$) \leftrightarrow Perovskite ($(\text{Mg,Fe})\text{SiO}_3$) + Magnesio-wüstite ($(\text{Fe,Mg})\text{O}$)
850-900	Pyrope ($\text{Mg}_3\text{Al}_2\text{Si}_3\text{O}_{12}$) \leftrightarrow Perovskite ($(\text{Mg,Fe})\text{SiO}_3$) + Sodium solution of Corundum (Al_2O_3) and Ilmenite ($(\text{Mg,Fe})\text{SiO}_3$)
1200	Stishovite (SiO_2) \leftrightarrow SiO_2 (CaCl ₂ structure)
1700	Metallization of chemical bonds in Wüstite (FeO)
2000	SiO_2 (CaCl ₂ structure) \leftrightarrow SiO_2 (structure intermediate between PbO and ZrO ₂)
2200-2300	Corundum (Al_2O_3) \leftrightarrow Al_2O_3 (Rh ₂ O ₃ structure)
	D" layer
2800-2900	Complicated phase relations, partial melt
Outer Core	
2900	Liquid Iron

Table 1.2: Depth and Phase Transformations in the Earth's Mantle and Core

Perovskite is the name for materials similar to calcium titanate (CaTiO_3), a mineral composite first discovered in 1839 composed of calcium, titanium, and oxygen. The family of solid-state materials which have calcium titanate structure collectively then termed as perovskites. These two terms have been often used interchangeably. The name perovskite gave on behalf of the famous Russian mineralogist, Count Lev Alekseevich Perovski (1792–1856) and the mineral was first found out in the Ural Mountains by Gustav Rose. Victor Goldschmidt in 1926 was the first

who identified the detailed perovskite crystal structure through the work on tolerance factor [4]. Helen Dick Megaw, in 1945 came with a structure derived from X-ray diffraction data for the first time [5]. Table 1.3 represents the evolution of perovskite structure and applications throughout the centuries [6].

The perovskite crystal family is a group of materials that have been attracting attention in recent years due to their exceptional properties and potential applications in nanotechnology. One of the most exciting areas of research is their use in the development of nanostructured solar cells. These materials have the potential to significantly improve the efficiency and cost-effectiveness of solar energy conversion, making them a highly promising area of research for scientists and engineers. With their unique physical and chemical characteristics, perovskites have the potential to revolutionize the way we harness and utilize solar energy.

Period	Inventor/organization	Description
1839	Gustav Rose (Berlin, Germany)	During an expedition in Russia, he discovered the mineral based on CaTiO_3 in the Ural Mountains. The mineral was named “perovskite” after the Russian mineralogist Lev Aleksevich von Perovski
1892	H.L. Wells, G.F. Campbell, P.T. Walden and A.P. Wheeler/ Sheffield Scientific School (New Haven Conn)	Prepared compounds based on caesium, lead and halides from aqueous solutions.
1947	Philips (Eindhoven, the Netherlands)	Introduced barium titanate for production of condensers
1952	Perovskite introduced into catalysis	Original articles on this regard reported in the several years of 1952[7], 1953[8] and 1965[9].
1955	Western Electric (New York, N.Y.)	Reported the use of ferroelectric crystalline oxides with perovskite structure for fabrication of electromechanical transducers
1957	C.K. Møller/ Chemical Laboratory at the Royal Veterinary and Agricultural College (Copenhagen, Denmark)	Evaluated the microstructure of the compounds produced by H.L. Wells and his collaborators and found that they had a perovskite structure
1957	Siemens (Munich, Germany)	Developed barium titanate-based resistors
1959	Clevite (Cleveland, Ohio)	Introduced perovskite materials in the fabrication of piezoelectric resonators for electromechanical filters.
1962	A.E. Ringwood/ Australian National University (Canberra, Australia)	Proposed that the Earth’s lower mantle is made primarily of MgSiO_3 perovskite.
1964	Compagnie Generale d’Electricité (Paris, France)	Developed perovskite-based solid electrolytes for fuel cells.
1971	Corning Glass Works (Corning) (N.Y.)	Reported the use of perovskite oxides in frits for glass-ceramic articles.
1971	Exxon Research Engineering (Linden, N.J.)	Developed perovskite-based cathode catalysts for electrochemical cells used to convert alcohols into ketones.
1975	Hitachi (Tokyo, Japan)	Manufactured the first gas sensors based on oxide perovskites
1978	D. Weber/University of Stuttgart (Stuttgart, Germany)	Developed the first organic-inorganic halide perovskites
1979	NGK Insulators (Nagoya, Japan)	Introduced a honeycomb structural body based on barium titanate for use as heating element
1981	GTE Laboratories (Waltham, Mass.)	Introduced lasers based on perovskite crystals
1988	Ferranti Plc (Oldham, U.K.)	Developed a superconducting composition with a perovskite Structure
1994	D.B. Mitzi et al. IBM (Yorktown Heights, N.Y.)	Developed luminescent organic inorganic halide perovskites for light-devices

Period	Inventor/organization	description
1996	Boeing North America (Seal Beach Calif.)	Introduced caesium-germanium halide salts with perovskite structure as nonlinear optical crystals for Optoelectronics
1999	Murase Chikao et al., National Institute of Advanced Industrial Science and Technology (Tokyo, Japan)	Created an optical absorption layer for a solar cell using a rare earth oxide having a perovskite crystal structure
2000 and beyond		New processes for fabrication of solar cells based on perovskite materials were developed leading to an increase of activities in this field, the creation of first devices.

A perovskite structure is a substance that has the generic form ABX_3 and the same crystallographic structure as perovskite (the original mineral). In the periodic table shown in Fig. 1.1 the elements that generally occupy the A or B site cationic positions are indicated. It is seen that almost all elements except the ones that exist either in a gaseous or liquid state under normal conditions can occupy either of these two positions in the perovskite structure.

The perovskite lattice arrangement is shown in Fig.1.2. As is usual with structural science and

IA																	0		
H	IIA											B	C	N	O	F	He		
Li	Be											Al	Si	P	S	Cl	Ar		
Na	Mg	IIIA	IVA	VA	VIA	VIIA	← VIII →					IB	IIB	Al	Si	P	S	Cl	Ar
K	Ca	Sc	Ti	V	Cr	Mn	Fe	Co	Ni	Cu	Zn	Ga	Ge	As	Se	Br	Kr		
Rb	Sr	Y	Zr	Nb	Mo	Tc	Ru	Rh	Pd	Ag	Cd	In	Sn	Sb	Tc	I	Xe		
Cs	Ba	La	Hf	Ta	W	Re	Os	Ir	Pt	Au	Hg	Tl	Pb	Bi	Po	At	Rn		
Fr	Ra	Ac																	
			Ce	Pr	Nd	Pm	Sm	Eu	Gd	Tb	Dy	Ho	Er	Tm	Yb	Lu			
			Th	Pa	U	Np	Pu	Am	Cm	Bk	Cf	Es	Fm	Md	No	Lr			

Figure 1.1: The Periodic Table showing the possible A and B site elements

in crystallography, perovskites can be represented in multiple ways. The simplest way to conceive a perovskite structure is to have a large atomic or molecular cation (positively-charged) of type A in the centre of a cube. The corners of the cube are then occupied by ions of the type B (also positively-charged cations), and the faces of the cube are occupied by the anion X with a negative charge. More on the structure of perovskites will be dealt with in the subsequent chapters.

Various oxide compounds are known to belong to a few perovskite-based homologous series, such as $A_{n+1}B_nO_{3n+1}$ Ruddlesden-Popper, $A_nB_nO_{3n+1}$ Dion-Jacobson, $Bi_2A_{n-1}B_nO_{3n+3}$ Aurivillius series and some others. The perovskite structures exist in different forms such as:

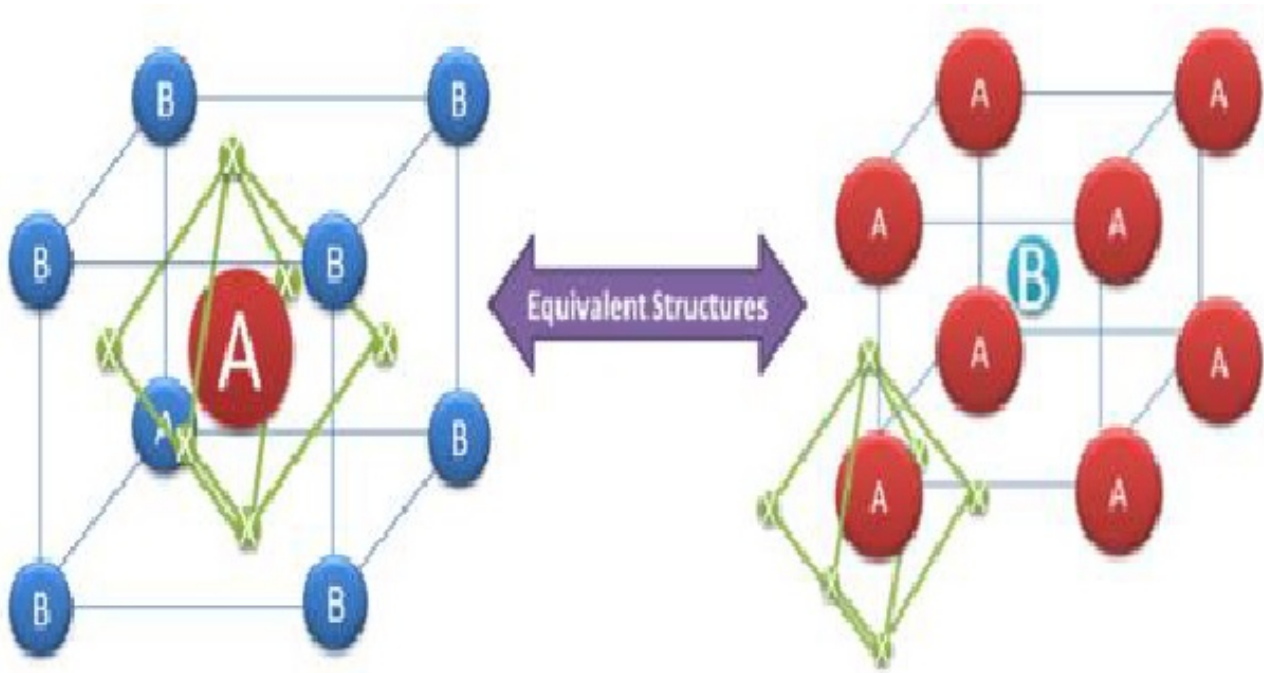

Figure 1.2: Two equivalent structures of perovskite structures with left-hand side is drawn with B site ion at $\langle 0,0,0 \rangle$ and the right-hand diagram with A site ions at $\langle 0,0,0 \rangle$ position [10].

ABO_3 perovskite (ex: $BaTiO_3$, $CaTiO_3$), A_2BO_5 Layered perovskite (ex: Sr_2RuO_4 , K_2NiF_4), $A_2BB'O_6$ Double perovskite (ex: Ba_2TiRuO_6) and $A_2A'B_2B'O_9$ Triple perovskite (ex: $La_2SrCo_2FeO_9$). Several perovskite-type oxides have been extensively studied due to their new properties including superconductivity, insulator-metal transition, ionic conduction characteristics, dielectric properties, optoelectronic property and ferroelectricity. Perovskite is one of the most frequent studied structures in solid-state chemistry, and it accommodates as stated above, most of the metal ions in the periodic table with a significant number of different anions. During the last few years, many investigations were focused on the study of perovskite solids, typically ABO_3 . These solids are currently gaining considerable importance in the field of electrical ceramics, refractories, geophysics, material science, astrophysics, particle accelerators, fission-fusion reactors, heterogeneous catalysis, environment and others. Perovskite structured oxides can accept considerable substitutions in one or both cationic sites (i.e. A and B sites) while retaining their original crystal structures. Such a feature provides the chemical tailoring of the materials via partial replacement of the cationic site(s) with foreign metal ions, hence modifying their structural, microstructural, electrical and magnetic properties. Perovskite-type oxides and perovskite-like oxides have found many applications in physics and chemistry. The physicochemical and device application properties of perovskites are dependent on the crystal structure, lattice defect, exposed lattice plane, surface morphology, particle size, and specific surface area as well as the porous texture. The cubic perovskite is called the ideal one. This class of materials has excellent potential for a variety of device applications due to their simple crystal structures and unique ferroelectric and dielectric properties. Perovskite systems can crystallise in a variety of compositions. There can be a variety of combinations of cations like A^+B^{5+} , $A^{2+}B^{4+}$, $A^{3+}B^{3+}$ and a host of defect compositions in ABX_3 systems. The following flow diagram (Fig.1.3.) with examples demonstrates this concept [11-12].

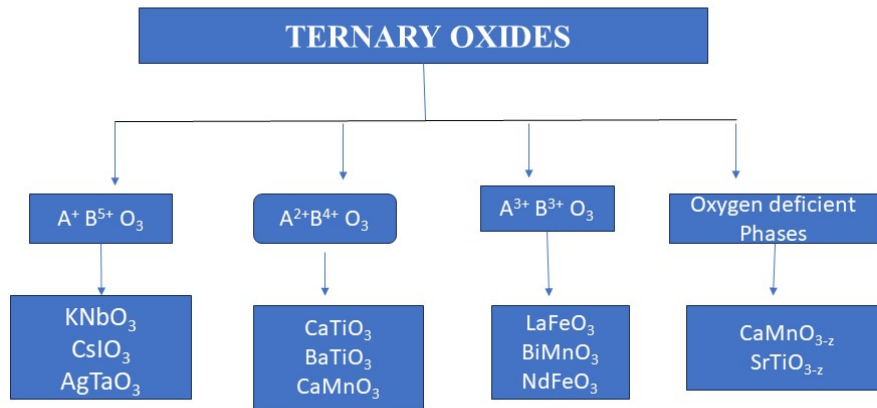

Figure 1.3: Flow diagram of the generation of variety of compositions in ABX_3 systems [11]

1.2 Properties of Perovskites

Perovskites is a derivative of the close packed structure in which the oxide ions are arranged in a cubic close packed arrangement except one oxide ion is missing in every second layer leaving a large volume empty in the centre. The Ti^{4+} ion occupies at the octahedral interstices, and the large cation Ca^{2+} fills the vacant cavity created in the centre by the missing of oxide ion with a coordination number 12. The ability of perovskite to accommodate large cations of rare earth element makes it as a unique among the close-packed oxides. If the 12-coordinated cation is smaller compared to the oxide ion, the tilting of octahedra distorts the perovskite structure. It usually takes place at a lower temperature and giving rise to many phase transformations. The modified structure produced after tilting could be tetragonal, orthorhombic or monoclinic or sometimes without any centre of symmetry. Non-centric perovskites display piezoelectricity or ferroelectricity, and synthetic perovskites used as electronic sensors. The structure of newly discovered high-temperature superconductors show resemblance to perovskite structure. In these superconducting materials Cu substitutes Ti in the layers and shows superconductivity at slightly elevated temperatures.

1.3 Applications

Perovskite materials find application in many devices' manufacture. Inorganic perovskite oxides are fascinating materials due to its very stable structure, the possibility of generating a large number of compounds, variety of surface and bulk properties and find many applications. These solids are currently gaining considerable importance in the field of electronics, geophysics, astrophysics, nuclear, optics, optoelectronics, environment, solar cells and catalysis. Perovskite-phase metal oxides exhibit a variety of interesting physical properties which include ferroelectric, dielectric, pyroelectric, piezoelectric, superconductivity, multiferroic, proton conducting, Colossal Magnetoresistance (CMR), Giant Magnetoresistance (GMR), mixed conduction, cat-

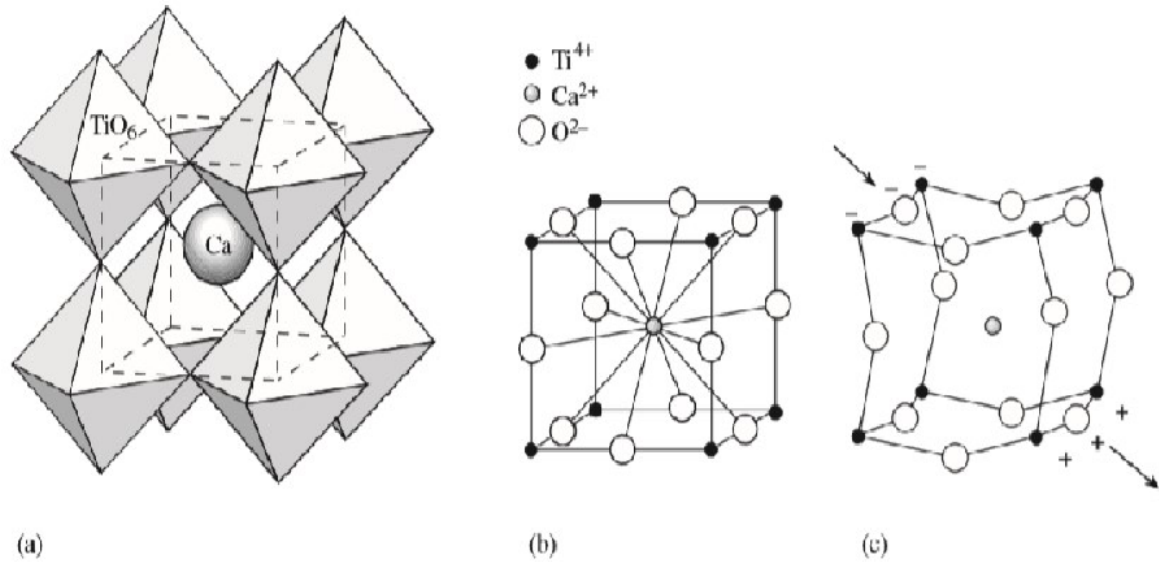

Figure 1.4: (a) Polyhedral representation of the structure of perovskite, showing the large 12-fold coordinated Ca^{2+} in the centre of the cubic unit cell and the smaller 8-fold coordinated Ti^{4+} in the corners. (b) Representation of perovskite structure with small spheres. (c) The perovskite structure distorts when stress is applied, creating an electric field (piezoelectricity). Reproduced from [3]

alytic behaviour and solar energy conversion. Depending on these distinct properties perovskite systems find use in various device applications such as (1) Thin film capacitors (2) Non-volatile memories; (3) Photoelectrochemical cells; (4) Recording applications (5) Read heads in hard disks, (6) Spintronics devices (7) Laser applications, (8) For windows to protect from high-temperature infrared radiations, (9) High temperature heating applications (Thermal barrier coatings) (10) Frequency filters for wireless communications (11) Non-volatile memories (12) Sensors, actuators and transducers, (13) Drug delivery, (14) Catalysts in modern chemical industry (15) Ultra-sonic imaging, ultra-sonics and underwater devices, (16) microwave devices and so on. Perovskites exhibit many new and unique properties, and some of the properties exhibited by typical perovskites are assembled in Table .4

1.4 Perspectives

Perovskites are unique today among all the known solid-state materials with a variety of applications contrasting in a property like highly resistive (Positive temperature coefficient materials) to highly conducting materials (superconductor). As stated above nearly all the elements can be included in the perovskite structure, and since this structure tolerates partial substitution at both the cationic sites and several anions can be placed in the perovskite composition, the number of materials that can be obtained in perovskite composition appears to be in numerous. Many of these perovskite materials are revolutionising the application potential and are becoming competitive to the existing materials like silicon for solar cell application.

The flexibility of the ABO_3 perovskite crystal structure and the possibility to include a wide range of cations with different oxidation states as well as cation or anion vacancies are responsible for the variety of perovskite-based compounds with a wide range of physical properties. Due to the number of applications and utility in the different fields, there is a need to study

Comounds	Properties	Applications	Notes
BaTiO ₃	Ferroelectricity piezoelectricity high dielectric constant	Multilayer Ceramic capacitors (MLCCs) PTCR resistors embedded capacitance	most widely used dielectric ceramic T _c = 125 ⁰ C
(Ba, Sr) TiO ₃	Non-linear dielectric Properties	Tunable microwave devices	Used in th paraelectric state
(Pb, Zr) TiO ₃	Ferroelectricity, piezoelectricity	piezoelectric transducers and actuators erroelectric memorie (FERAMs)	PZT most successful successful Piezoelectric Material
Bi ₄ Ti ₃ O ₁₂	Ferroelectric with high Curie Temperature (T _c)	High-temperature actuators, FeRAMs	Aurivillius compound T _c = 675 ⁰ C.
(K _{0.5} Na _{0.5} NbO ₃	ferroelectricity, piezoelectricity	lead free Piezoceramics	perormance not yet comparable to PZT but progress
(Pb,La)(Ti,Zr)O ₃	Transparent ferroelectric	optoelectroic devices	first transparent ferroelectric ceramic
BiFeO ₃	Magnetoelectric coupling, high Curie temperature	Magnetic field detectors, memories	Most investigated multiferroic compound T _c = 850 ⁰ C
PbMg _{1/3} Nb _{2/3} O ₃	Relaxor ferroelectric	Capacitors, actuators	High permittivity significantelectrorestictiv ccoefficients, frequency dependent properties
SrRuO ₃	Ferromagnetism	Electrode material for epitaxial ferroelectric thin films	
()La, A) MnO ₃	Ferromagnetism, giant magnetoresistance, spin polarised electrons	Magnetic field sensors, spin electronic devices	
SrTiO ₃	Incipient ferroelectricity thermoelectric power Metallic electronic conduction when n doped mixed conduction when p doped, photocatalyst	alternative gate dielectric material barrier layer capacitors, a substrte for epitaxial Growth photo-assisted water splitting	multifunctional materials
LaGaO ₃ BaIn ₂ O ₅	Oxide-ion conductio	he electrolyte in solid oxide fuel cells (SOFCs)	BaIn ₂ O ₅ is an oxygen-deficient perovskite with Brownmillerite structure
BaCeO ₃ , BaZrO ₃	Proton conduction	The electrolyte in protonic solid oxide fue cells(PSOFCs)	High protic conduction at 500 -700 ⁰ C
(La, Sr) BO ₃	Mixed conduction catalyst	The cathode material in SOFCs, oxygen separation membranes Membrane reactors Controlled oxidation of hydrocarbons	used in SOFC cathodes
LaAlO ₃ , YAlO ₃	Host materials for rare earth luminescent ions	Lasers Substrates for epitaxial film deposition	

the perovskite structured materials with improved properties, and this can be realized through new synthesis strategy and using different valence cations or anions and dopants.

The possibility of including organic cations like methylammonium and a host of other organic cations impart to the resulting system a variety of properties. The ionic radius of such organic cations has a high bearing on the properties of resultant perovskites. This concept of structures based on the ionic radius and their radius ratio has to be modified concerning the crystallisation of hybrid organic-inorganic perovskites, and these aspects require careful consideration.

1.5 Conclusion

The crystallization in perovskite structure is considered in terms of tolerance factor defined, in terms of cation and anion radii, and the universal applicability of this concept for adopting perovskite structure needs a careful examination. There are a variety of questions that one can have on perovskite materials like why the anion oxide perovskites are so crucial in the application field or why other compositions also crystallise in perovskite structure? The complete understanding of these aspects will be essential for exploiting them in the application field.

Bibliography

- [1] Cahn, R. W. (Ed.). *Chapter 1 - Introduction. In: The Coming of Materials Science (Vol. 5, pp. 3–17)*. Pergamon, 2001.
- [2] Yuanbing Mao, Hongjun Zhou, Stanislaus S. Wong. Synthesis, Properties, and Applications of Perovskite-Phase Metal Oxide *Nanostructures*, *Material Matters*, 2010, **5**(2), 50.
- [3] Hans-Rudolf Wenk, Andrey Bulakh. Chapter 25 - Oxides and hydroxides. Review of ionic crystals. In: *Minerals: Their Constitution and Origin*, Cambridge University Press, 2004.
- [4] Goldschmidt, V. M. (1926). Die Gesetze der Krystallochemie. *Naturwissenschaften*, 14(21), 477–485.
- [5] Megaw, H. Crystal Structure of Barium Titanate. (1945). *Nature*, **155**(3938), 484–485.
- [6] Gagliardi, M. Perovskite Solar Cells: Materials, Fabrication, and Global Markets, BCC Research, <https://bit.ly/2YeJ8s5>
- [7] Parravano, G. (1952). Ferroelectric Transitions and Heterogeneous Catalysis. *The Journal of Chemical Physics*, **20**(2), 342–343.
- [8] Parravano, G. (1953). Catalytic Activity of Lanthanum and Strontium Manganite. *Journal of the American Chemical Society*, **75**(6), 1497–1498.
- [9] Dickens, P. G., & Whittingham, M. S. (1965). Recombination of oxygen atoms on oxide surfaces. Part 2. Catalytic activities of the alkali metal tungsten bronzes. *Transactions of the Faraday Society*, **61**, 1226–1231.
- [10] Perovskites and Perovskite Solar Cells: An Introduction, <https://bit.ly/2a4utpF>
- [11] Jadhav, K. M. Investigations of electrical and magnetic properties of some perovskite structured materials, PhD Thesis, Dr. Babasaheb Ambedkar Marathwada University, 2017. <https://bit.ly/2X81AJ0>
- [12] Rama Murthy P. S. Study of structural, transport and magnetic properties of some perovskite based oxides, PhD Thesis, Goa University, 2010.
- [13] The Huy Bui, Joung Jo Shim, Perovskite materials for sensing applications, Recent advances and Challenges, *Microchemical Journal*. **191**,(2023)108924.
- [14] handra Babu Naidu, A review of Perovskite solar cells(PSCs) Materials and applications, *Journal of Materiomics*,**7**.(2024)940-956.
- [15] Lixiu Zhang Luyao Mei, Kaiyang Wang, Yinhua Lv, Shuai Zhang, Yaxiao Lian, Xiaoke Liu, Zhiwei Ma, GuanJun Xiao, Qiang Liu, Shuaibo Zhai, Shengli Zhang, Gengling Liu, Ligang Yuan, Bingbing Guo, Ziming Chen, Keyu Wei, Aqiang Liu, Shizhong Yue, Guangda Niu, Xiyan Pan, Jie Sun1, Yong Hua, Wu-Qiang Wu, Dawei Di, Baodan Zhao, Jianjun

- Tian, Zhijie Wang, Yang Yang, Liang Chu, Mingjian Yuan, Haibo Zeng, Hin-Lap Yip, Keyou Yan, Wentao Xu, Lu Zhu, Wenhua Zhang, Guichuan Xing, Feng Gao, *Nano micro Letters*,(15, (2023) 177.
- [16] Abdulaziz S. R. Bati, Yu Lin Zhong, Paul L. Burn, Mohammad Khaja Nazeeruddin, Paul E. Shaw and Munkhbayar Batmunkh, Next-generation applications for integrated perovskite solar cells, *COMMUNICATIONS MATERIALS* (2023) 42 <https://doi.org/10.1038/s43246-022-00325-4> |www.nature.com/commsmat
- [17] Gobeng R. Monama,Kabelo E. Ramohlola,Emmanuel I. Iwuoha Kwena D. Modibane, Progress on perovskite materials for energy application, *Results in Chemistry*, Volume 4, January (2022), 100321.
- [18] Edited by Poorva Sharma and Ashwini Kumar, Recent Advances in Multifunctional Perovskite Materials,Intech open (2022).

Chapter 2

STRUCTURE OF PEROVSKITES

2.1 Introduction-The Perovskite Structure

The perovskite has general formula ABX_3 . The 'ideal' perovskite structure, illustrated in Fig. 1a is cubic with atoms at the corners, edge centre and body centre. This structure is adopted by complex halides and by many complex oxides. The latter are very numerous because the sum of the charges on A and B (+6) may be made of 1+5, 2+4, or 3+3. The structure includes mixed oxide type materials such as $SrTiO_3$, $CaTiO_3$, $SrZrO_3$, $SrHfO_3$, $SrSnO_3$, and $BaSnO_3$. A unit cell of $SrTiO_3$ is shown in Fig. 1b, this unit cell is known as the A-type because, if we take the general formula ABX_3 for the perovskites, then the A atom is at the centre in this cell. The central Sr(A) atom is coordinated to 8 Ti (B) atoms at the corners and 12 oxygens (X) at the centre of the cell edges. The structure can be usefully described in other ways. First, it can be described as a ccp/fcc (cubic close packing/face-centred cube) array of A and X atoms with the B atoms occupying the octahedral hole. Second, perovskite has the same octahedral framework as ReO_3 based on BX_6 octahedra with an A atom added in at the centre of the cell.

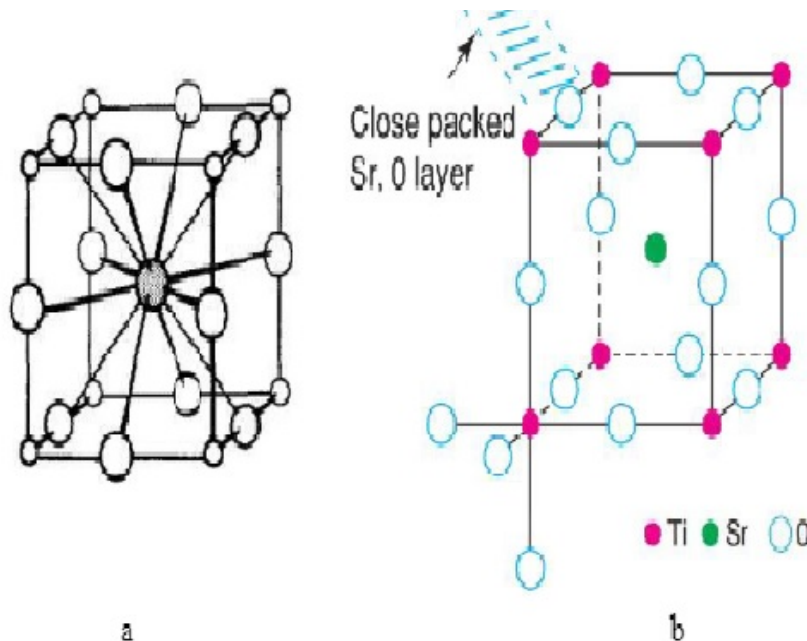

Figure 2.1: (a) Unit cell of cubic perovskite structure [1]; (b) unit cell of $SrTiO_3$ [2].

To understand the perovskite structure in detail, we need to understand a few basics such as ccp(cubic close packing),concept of voids and structure of ReO_3 . This will help us view

perovskite structure from a different point of view for better visualisation.

2.2 Cubic Close Packing (CCP)

During crystal growth, the atoms arrange in different ways to give crystal. For our understanding, let us arrange atoms layer by layer. Atoms in the first layer (layer A) can be arranged/packed in two different ways; a) a square array of spheres; b) a close-packed layer of spheres as shown in Fig. 2a and b. The close packing can be visualised as a squeezed square layer. To build up a close-packed structure in three-dimensions, we must now add a second layer (layer B). The spheres of the second layer sit in half of the hollows of the first layer; these have been marked with dots and crosses. The layer B in Fig. 3 sits over the hollows marked with a cross (although it makes no difference which type we chose).

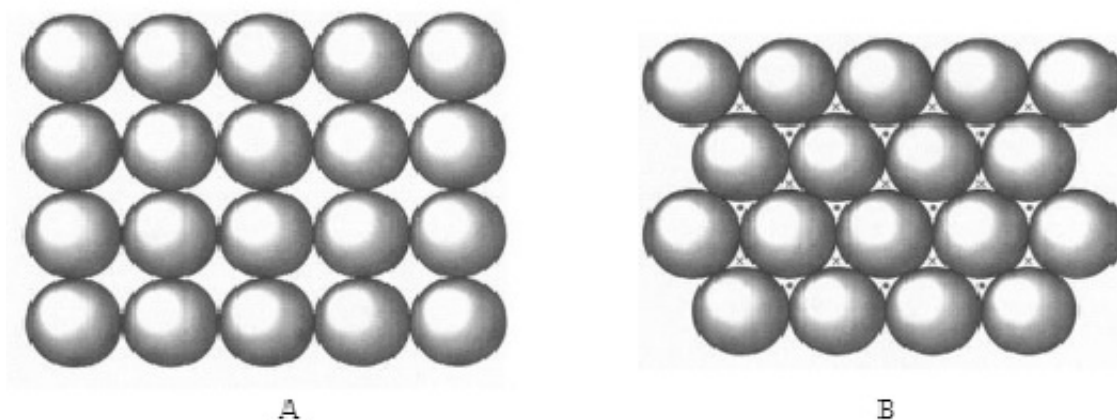

Figure 2.2: A square array of spheres; (b) a close-packed layer of spheres.[3]

When we add a third layer, it could be positioned over those hollows marked with a dot. This third layer, which we could label C, would not be directly over either A or B layer and the stacking sequence when repeated would be ABC ABC AB...and so on. This is known as cubic close-packing (ccp) (Fig. 4) (The name cubic arise from the resulting symmetry of the structure). In a 3D close packed structure, each sphere is in contact with with 12 others, and this is the maximum coordination number possible for contacting and equal-sized spheres. Close-packing represents the most efficient use of space when packing identical spheres—the spheres occupy 74% of the volume: the packing efficiency is said to be 74%. Each sphere in the structure is surrounded by twelve equidistant neighbours—six in the same layer, three in the layer above and three in the layer below: the coordination number of an atom in a close-packed structure is thus 12 as shown in Fig. 5 (a).

The unit cell of a ccp arrangement is the familiar face centred cubic (fcc) unit cell, Fig. 5 (b), with spheres at corner and face centre positions.

2.3 Voids in crystal: Octahedral (O) and Tetrahedral (T_+ and T_-)

An important feature of close-packed (cp) structures is the shape and number of the small amounts of space trapped in between the spheres. Two different types of spaces are contained

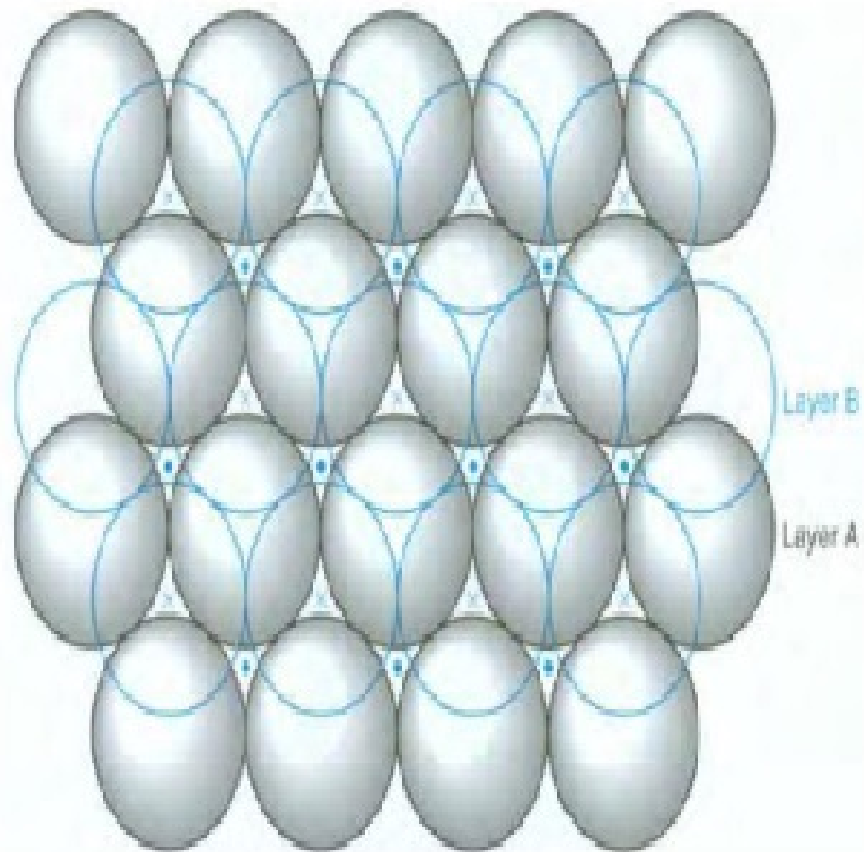

Figure 2.3: Two layers of close-packed spheres.[3]

within a close-packed structure: a) octahedral void and b) tetrahedral void. Firstly, the octahedral void is the space present between six spheres of two cp layers A and B: three spheres in layer A and three in layer B, as shown in Fig. 6a and b. The centres of these spheres lay at the corners of an octahedron, hence the name. If n spheres are in the array, then there are also n octahedral holes. Whereas, the tetrahedral void is the space present between four spheres of two cp layers A and B, wherein three spheres that form the base of the tetrahedron belong to one cp layer with the apex of the tetrahedron either in the layer above or below. This gives two orientations of tetrahedral sites, T_+ and T_- , in which the apex is up and down, respectively as shown in Fig. 6a and c, with centres of the spheres at the corners of a tetrahedron hence the name. If n spheres are in the array, then there are $2n$ tetrahedral holes. No. of octahedral voids with n atoms = n atoms No. of tetrahedral voids with n atoms = $2n$ atoms. Since there are 4 atoms in a ccp/fcc unit cell, hence there are 4 octahedral voids and 8 tetrahedral voids in a ccp/fcc unit cell..

2.4 Location of tetrahedral and octahedral sites in an fcc/ccp unit cell

It is important to visualise and understand the locations of these voids (T_+ , T_- , and O) in a unit cell since in crystals these voids are generally occupied by small ions/cations. As shown in Fig. 7, an fcc (face-centered cubic) or ccp (cubic close-packed) unit cell has anions, X, at the corners and face centers (A, B, C, and D). The octahedral sites are easiest to locate; they

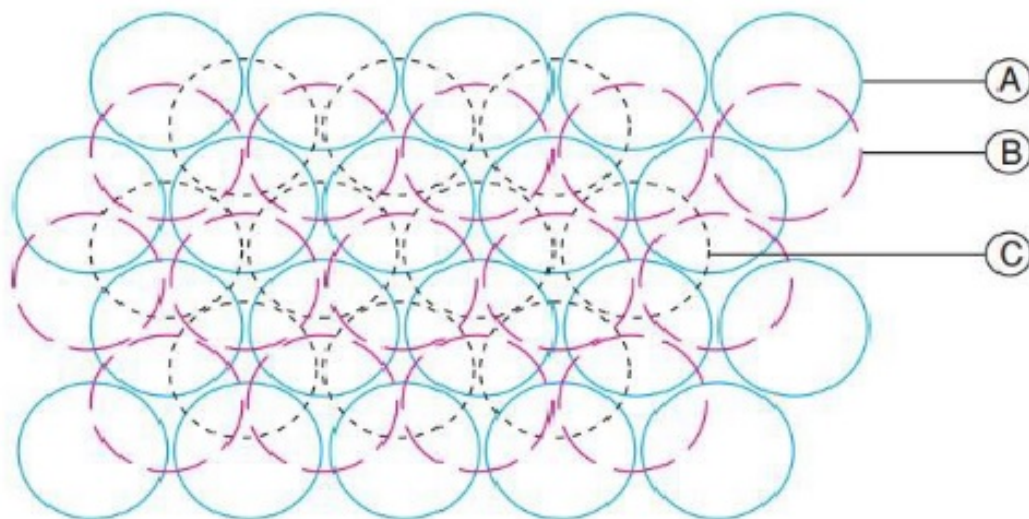

Figure 2.4: Cubic close-packing (ccp) with ABC layer sequence.[2]

are at edge-center (positions 1, 2, 3) and body-center (position 4). If the unit cell has length a , the M-X distance for octahedral sites is $\frac{a}{2}$. To see the T_+ and T_- sites clearly, it is convenient to divide the unit cell into eight mini-cubes by bisecting each cell edge (dashed lines). These mini-cubes contain anions at only four of the eight corners; in the middle of each mini-cube is a tetrahedral site, either T_+ or T_- .

2.5 ReO_3 Structure

It is a primitive cube structure consisting of ReO_6 octahedra linked together through each corner to give a highly symmetrical three-dimensional network. Part of the structure with single octahedral coordination is given in Fig. 8a, and the linking of the octahedra in 8b.

2.6 The Perovskite Structure

: Through ReO_3 structure and CCP/FCC and voids Perovskite has primitive cubic unit cell and octahedral framework as ReO_3 based on BX_6 octahedra. With an A atom added in at the centre of the unit cell of ReO_3 we will get perovskite structure. For example- SrTiO_3 as shown in Fig. 9a, with Sr atoms occupying the body center $(\frac{1}{2}, \frac{1}{2}, \frac{1}{2})$, Ti atoms occupying cube corners $(0,0,0)$ and oxygen atoms occupying edge centers $(\frac{1}{2}, 0, 0; 0, \frac{1}{2}, 0; 0, 0, \frac{1}{2})$. The 3D and 2D-view of SrTiO_3 structure are shown in Fig. 9a and b. O has two T_+ as its nearest cationic neighbors, whereas Sr is coordinated with 8 Ti atoms and 12 oxygen atoms. SrTiO_3 can also be represented as a ccp/fcc array Sr and O, with Sr occupying cube corners and O at face centers and with the Ti atoms occupying the body center octahedral void of fcc lattice as shown in Fig. 10a and b. The two descriptions in Fig. 9a and 10a are interchangeable and are simply related by translation of the origin half way along the cube body diagonal.

Perovskite is also regarded as a framework structure with corner-sharing TiO_6 octahedra and with Sr in 12-coordinate interstices. The octahedral coordination of one Ti is shown in Fig. 11; each O of this octahedron is shared with one other octahedron, such that the Ti-O-Ti

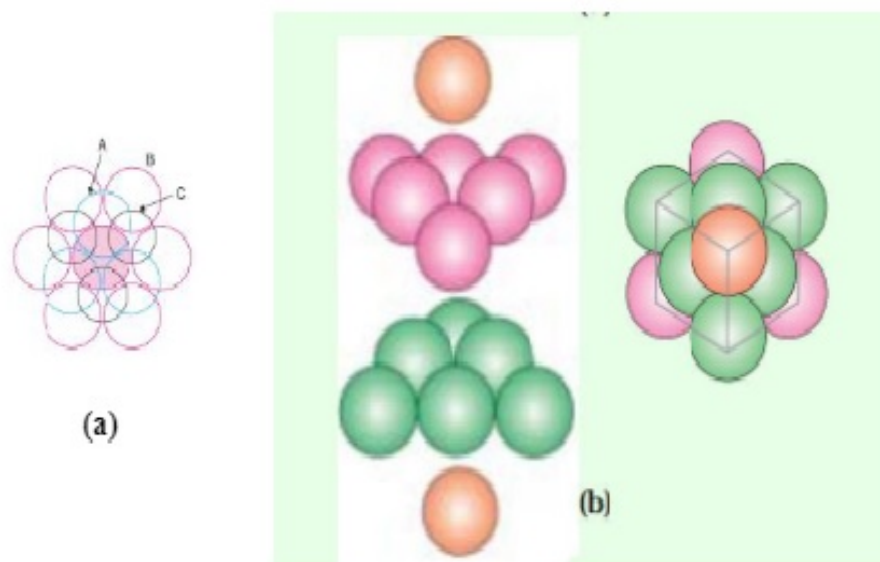

Figure 2.5: (a) Coordination number 12 of the shaded sphere in ccp; [2] (b) face centred cubic (fcc) formed from ccp. [4]

arrangement is linear. Thus, octahedra link at their corners to form sheets, and neighbouring sheets link similarly to form a 3D framework.

2.7 suggested Reading Resources

1. Wells, A.F., (2012). Structural inorganic chemistry. Oxford university press.
2. West, A.R., (2014). Solid state chemistry and its applications. John Wiley and Sons.
3. Smart, L.E. and Moore, E.A., (2016). Solid state chemistry: an introduction. CRC Press.
4. Chemistry class 12th PART 1 ncert, 2017.

2.8 Distortion in Perovskite Structure

The 'ideal' perovskite structure, illustrated in Fig. 9, is cubic, with A surrounded by 12 O and B by 6 O. Comparatively few compounds have this ideal cubic structure, many (including the mineral perovskite, CaTiO_3 ; itself) having slightly distorted variants with lower symmetry. Some examples are listed in Table 1. These departures from the most symmetrical structure are of great interest because of the dielectric and magnetic properties of these compounds. For example, many are ferroelectric, notably BaTiO_3 , some are anti-ferroelectric, for example, PbZrO_3 and NaNbO_3 , and ferromagnetic ($\text{LaCo}_{0.2}\text{Mn}_{0.8}\text{O}_3$) and anti-ferromagnetic (GdFeO_3 , LaFeO_3 , etc.) compounds are known.

In order to understand the distortions from the ideal cubic structure these oxides ABO_3 were first regarded as purely ionic crystals. From the geometry of the structure it follows that for the 'ideal' structure there is the following relation between the radii of the A, B, and O^{2-} ions as shown in equation (1): wherein r_A , r_B and r_X are ionic radius of A-site cation, B-site cation and X is anion (O^{2-} , halogens etc).

$$R_A + R_X = \sqrt{2}(r_B + R_X) \dots\dots\dots 1)$$

Actually the cubic perovskite structure or slightly deformed variants of it are found for ions which do not obey this relation exactly, and this was expressed by introducing a 'tolerance

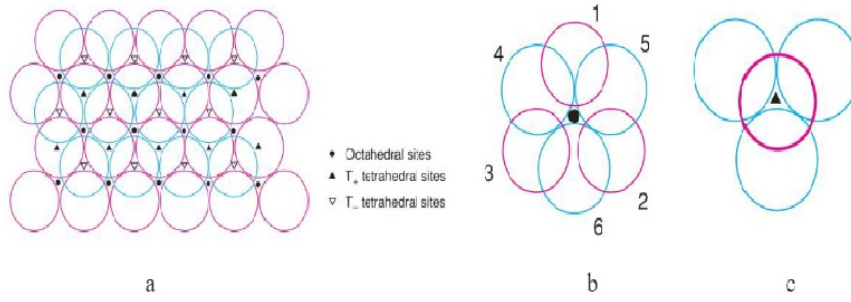

Figure 2.6: (a) Two cp layers showing octahedral and tetrahedral spaces; (b) octahedral void formed with 6 spheres; (c) tetrahedral void formed with 4 spheres.[2]

factor', the ratio of ionic sizes that perovskite architectures can tolerate is indicated by the Goldschmidt tolerance factor (t) as shown in equation (2) and (3):

$$r_A + r_X = t\sqrt{2}(r_B + r_X) \quad (2) \quad (2.1)$$

$$\text{Tolerance factor } t = \frac{r_A + r_X}{\sqrt{2}(r_B + r_X)} \quad (3) \quad (2.2)$$

In practice, there is some flexibility over bond lengths and usually, a cubic perovskite forms with t in the range 0.9 is less than or equal to t is less than or equal to 1.0. For t greater than 1, the B site is larger than required. If t is only slightly greater than 1.0, the structure distorts but is still basically a perovskite as in BaTiO_3 , t less than 1.06 as shown in Fig. 12a. The shifts of Ti and Ba are conventionally shown relative to the O_6 octahedra around the original Ti position. In BaTiO_3 Ti shifts by 0.12 Å and Ba in the same direction by 0.06 Å. The Ti environment in the crystal is shown in Fig. 12b, wherein Ti is displaced from the centre of its octahedron giving one short Ti-O distance of 1.86 Å, when compared to the mean value of 1.97 Å in rutile. this distortion has negligible effect on the twelve Ba-O distances. These distortions are the cause of ferroelectric behavior of BaTiO_3 .

For smaller tolerance factors, 0.85 less than t less than 0.90, several different kinds of structural distortions occur, as in GdFeO_3 , the A cation is too small for its site. These distortions generally involve tilting and rotation of the BO_6 octahedra as shown in Fig. 13. Consequently some, or all, of the B-O-B linkages are no longer linear but are zig-zag, which has the effect of reducing the size of the A cation site. The fact that the structures of compounds ABO_3 are dependent not only on size factors but also on the nature of B has been demonstrated in many comparative studies. For example, while AFeO_3 (A = lanthanide) all have perovskite-type structures this is true for $\text{AMn}^{3+}\text{O}_3$ only if A is La or Ce. The compounds in which A = Ho-Lu adopt a new hexagonal structure with 5- and 7-coordination of A site.

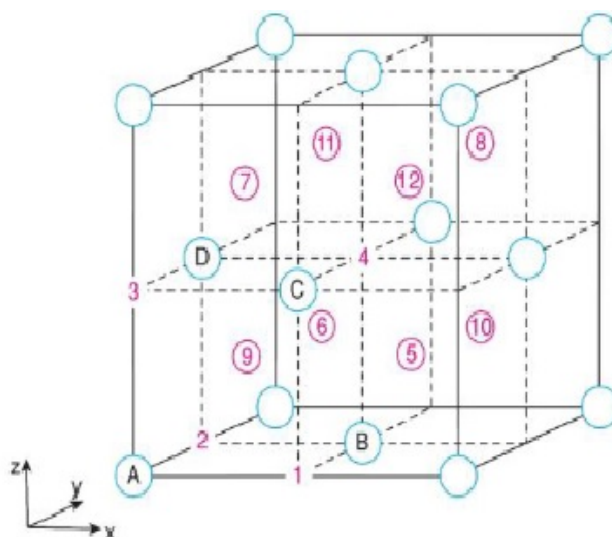

Figure 7. Available void/sites, 1–12, in an fcc/ccp array.[2]

Figure 2.7: caption required

Table 2.1: Compounds with the perovskite type of structure [1]

Ideal cubic structure	SrTiO ₃ , SrZrO ₃ , SrHfO ₃ , SrSnO ₃ , SrFeO ₃ , BaZrO ₃ , BaHfO ₃ , BaSnO ₃ , BaCeO ₃ , EuTiO ₃ , LaMnO ₃
At least one form with distorted small cell ($a = 4 \text{ \AA}$):	BaTiO ₃ (C, T, O, R)
Cubic (C)	KNbO ₃ (C, T, O, R)
Tetragonal (T)	KTaO ₃ (C, ?)
Orthorhombic (O)	RbTaO ₃ (C, T)
Rhombohedral (R)	PbTiO ₃ (C, T)
Distorted multiple cells	CaTiO ₃ , NaNbO ₃ , PbZrO ₃ , PbHfO ₃ , LaCrO ₃ , low-PbTiO ₃ , low-NaNbO ₃ , high-NaNbO ₃

2.9 Structure of Hybrid Organic-Inorganic Perovskite (HOIP)

Hybrid organic–inorganic perovskites (HOIPs) are a subclass of ABX₃ materials in which the A-site and/or X-site ions are replaced by organic amine cations and/or organic linkers, respectively. The organic components in the structure of these HOIPs introduce additional functionalities and structural flexibility that cannot be achieved in purely inorganic perovskites. Most importantly, their diverse structural and chemical variability offers substantial opportunities for tuning and modulating their physical properties by facile chemical modification. Hybrid perovskites were structurally characterized in 1978, with the report of the cubic phases of MAPbX₃ (MA = methylammonium and X = Cl, Br or I) as shown in Fig. 14.

By extending the X-site from a single halide to bridging molecular linkers, such as azide (N³⁻), cyanide (CN⁻) and borohydride (BH₄)⁻⁴, other families of HOIPs have been formed. The introduction of additional organic components in to the X-site gives another variety of HOIP derivative, namely metal–organic framework perovskites as shown in Fig.15. Metal formate and metal dicyanamide perovskites are well-known examples, in which the A-sites are

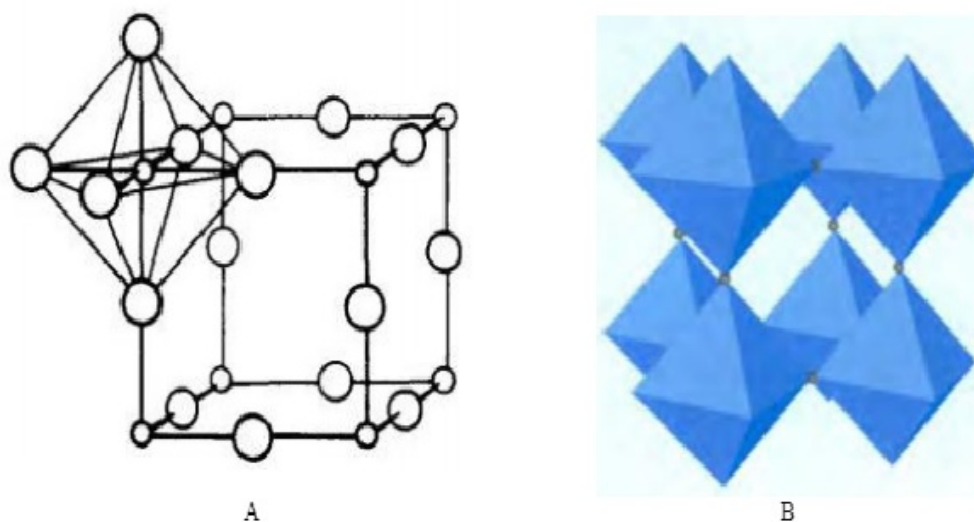

Figure 2.8: (a) a ReO₃ structure; [2] (b) ReO₃ structure showing the linking of [ReO₆] octahedra. [3]

amine cations and X-sites are (HCOO)⁻ or N(CN)²⁻ respectively. The abundant variations of organic components and metal salts offer enormous chemical possibilities for creating HOIPs, and, hence, this class of materials now spans a considerable part of the periodic table. For the 3D perovskites, the size of the organic A cation is limited by the size of the 3D hole into which it must fit. For a perfectly packed perovskite structure the geometrically imposed condition for the A, M, and X ions to be in close contact is given by equation 2 and 3 (tolerance factor) ‘t’ must satisfy t less than 1. Empirically it is found that 0.8 is less than or equal t less than or equal 0.9 for most cubic perovskites, although there is a slightly expanded range for distorted structures. Using t equal to 1 and essentially the largest values for r_B and r_X (e.g. $r_{Pb} = 1.19$, $r_I = 2.20$ Å), the limit on r_A is found to be approximately 2.6 Å. Consequently, only small organic cations (i.e. those consisting of three or less C-C or C-N bonds) are expected to fit into the structure. The possible A site, B site and X site combinations are presented in Fig. 16 in HOIPs, a significant number of tolerance factors are found to lie in the range approximately 0.8 to 1.0 as shown in Table 2. These results are similar to those for conventional perovskites and demonstrate the extended validity of the Goldschmidt tolerance factors. In addition, it is evident that the packing density has a pivotal role in the formation of HOIPs. Moreover, this simple semi-empirical approach for assessing size compatibility can guide the rational design and synthesis of new HOIPs using compositions with desired functionalities.

AZE, azetidinium; BTBA, benzyltributylammonium; BTEA, benzyltriethylammonium; DABCO, 1,4-diazabicyclo[2.2.2]octane; DMA, dimethylammonium; EA, ethylammonium; FA, formamidinium; GUA, guanidinium; HAZ, hydrazinium; HIM, imidazolium; HOIPs, hybridorganic-inorganic perovskites; MA, methylammonium; PIP, piperazinediium; PPN, bis(triphenylphosphoranylidene)ammonium; SPh₃⁺, triphenylsulfonium; t, tolerance factor; TMA, tetramethylammonium; TrMA, trimethylammonium.

2.10 Suggested Reading Resources

1. Wells, A.F., (2012). Structural Inorganic Chemistry. Oxford University Press.
2. West, A.R., (2014). Solid state chemistry and its applications. John Wiley and Sons.
3. Smart, L.E. and Moore, E.A., (2016). Solid state chemistry: an introduction. CRC press.

Figure 9. SrTiO₃ structure a) 3D-view; b) 2D-view.[2]

Figure 2.9:

Table 2.2: A summary of the chemical variabilities, crystal symmetries and physical properties of hybrid organic–inorganic perovskites

HOIPs	A-site	B-site	X-site	symmetry	Tolerance factor
Halides	MA and FA	Pn.Sn and Ce	Cl,Br,I ⁻	orthorhombic trigonal Tetragonal Cubic	0.912-1.142
	MA PIP	K ⁺ /Bi ³⁺ K,Cs,and RB	Cl	cubic monoclinic Orthorhombic Trigonal	0.906-0.923) .922-1.037
Formates	Cs ⁺ ,K ⁺ ,NH ₄ ⁺ ,MA, FA GUA,EA,DMA,AZE HIM and HAZ	Mg,Mn,Fe,Co Ni,Cu,Zn and Cd	(HCOO) ⁻	Monoclinic Orthorhombic Trigonal Tetragonal) .764 - 1.001 dielectricity
	HMA,DMA and EA	Na/Cr,Na/Al Na/Fe, K/Sc	(HCOO) ⁻	Triclinic Trigonal	Ferroelasticity 0.897-1.040
Azides	MA,DMA and TMA	MN,cd and Co	N ₃ ⁻	Triclinic monoclinic Cubic	0.736-1.023
	TMA	Na/Cr, Na/Fe K/Fe,K/Cr			0.934-1.008
Dicyanamides	BTBA,BIEA,SPh ₃ ,TMA	Mn,Fe,Co,Ni		Orthorhombic Tetragonal	1.142-1.166
Cyanides	HIM,dma.MA TMA,GUA	k/Fe,K/Co	CN ⁻	Triclinic Monoclinic	0.840-1.031
	Borohydrides	MA	Ca	BH ₄ ⁻	cubic

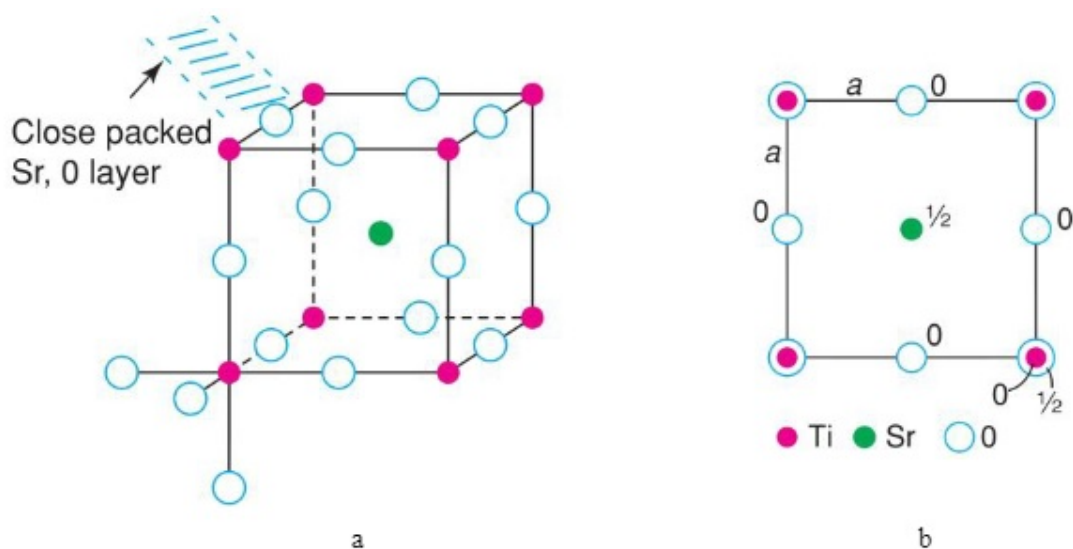
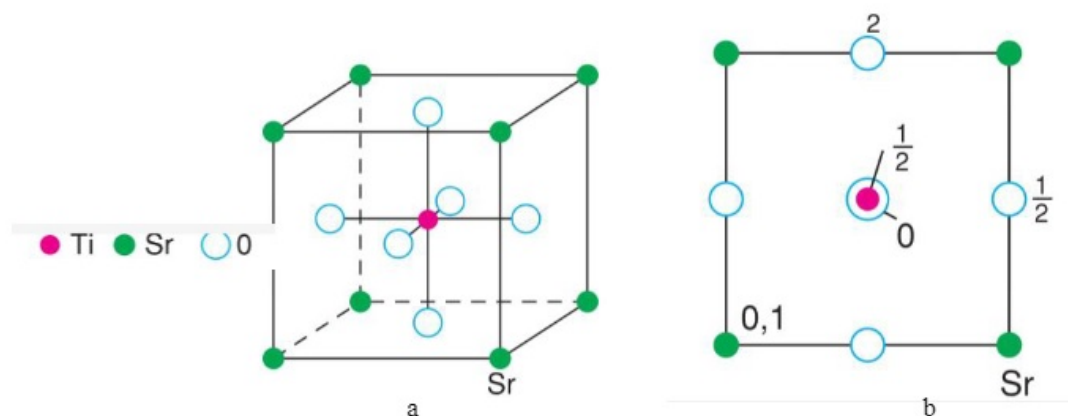

Figure 10. Translated view of SrTiO₃ structure a) 3D-view; b) 2D-view.[2]

Figure 2.10: caption required

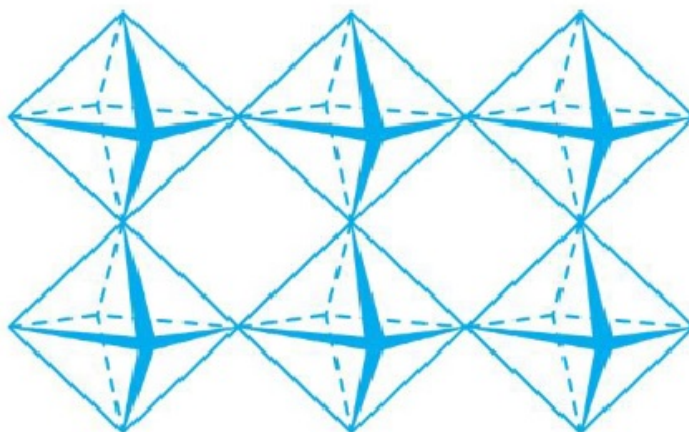

Figure 11. SrTiO₃ as corner sharing octahedral framework structure.[2]

Figure 2.11: caption required here

4. Chemistry class 12th PART 1 ncert, (2017)

5. Li, W., Wang, Z., Deschler, F., Gao, S., Friend, R.H. and Cheetham, A.K., (2017). Chemically diverse and multifunctional hybrid organic–inorganic perovskites. *Nature Reviews Materials*, 2(3), p.16099

2.11 A₂BO₄-Layered Perovskite:

The K₂NiF₄ structure: The K₂NiF₄ structure may be regarded as alternating layers of perovskite and rock salt structures, as shown in Fig. 17. The formula K₂NiF₄ could be written in expanded form as KNiF₃.KF to indicate the perovskite and rock salt components. The structure is body centred tetragonal with perovskite-like layers of octahedra centred at $c=0$ and $c=1/2$. K⁺ ions lie at the interface between rock salt and perovskite blocks and have a coordination number of 9. The coordination number of K in rock salt would be 12 but the rock salt blocks are less than one unit cell thick and the K coordination in rock salt is interrupted

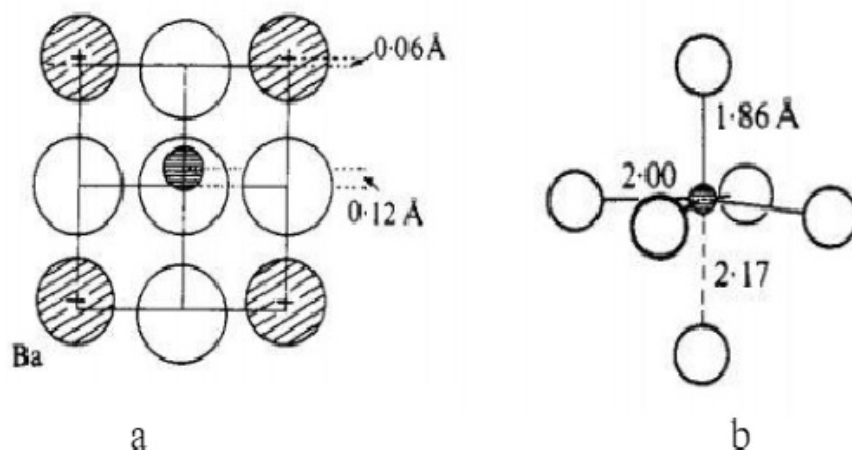

Figure 2.12: Distorted BaTiO₃ structure with $t = 1.06$ (a) 2D-view B distortion in Ti octahedra[2]

by the atomic displacements that generate perovskite block.

2.12 Double Perovskite, $A_2BB'O_6$

In the double perovskite $A_2B'B''O_6$ (where A is an alkaline-earth or rare-earth ion), the transition-metal sites (perovskite B-sites) are occupied alternately by different cations B' and B''. Sr₂FeMoO₆ is one such example, as depicted in Fig. 18. Intervening oxygen bridges every B' and B'' atom pair, thus forming alternating B'O₆ and B''O₆ octahedra.

2.13 References

1. Wells, A.F., 2012. Structural inorganic chemistry. Oxford University Press.
2. West, A.R., 2014. Solid state chemistry and its applications. John Wiley and Sons.
3. Smart, L.E. and Moore, E.A., 2016. Solid state chemistry: an introduction. CRC press.
4. Chemistry class 12th PART 1 ncert, 2017.5. Li, W., Wang, Z., Deschler, F., Gao, S., Friend, R.H. and Cheetham, A.K., 2017. Chemically diverse and multifunctional hybrid organic–inorganic perovskites. Nature Reviews Materials, 2(3), p.16099.
6. Kobayashi, K.I., Kimura, T., Sawada, H., Terakura, K. and Tokura, Y., 1998. Room-temperature magnetoresistance in an oxide material with an ordered double-perovskite structure. Nature, 395(6703), p.677

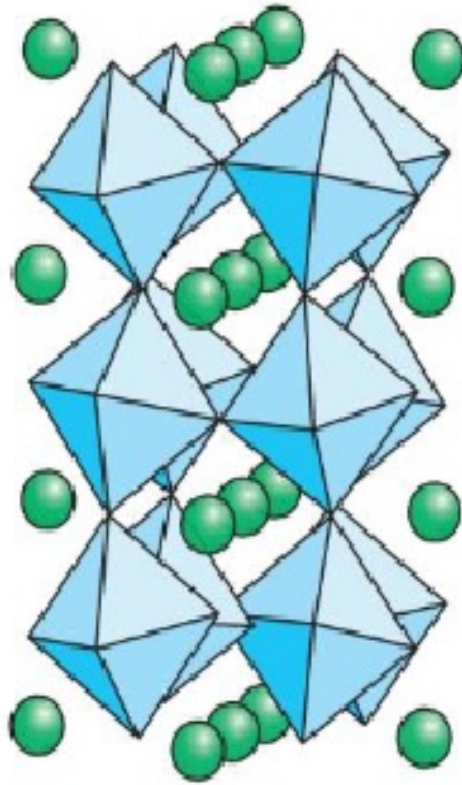

Figure 2.13: GdFeO_3 structure with $0.85 < t < 0.90$ showing tilting of the BO_6 octahedra.[2]

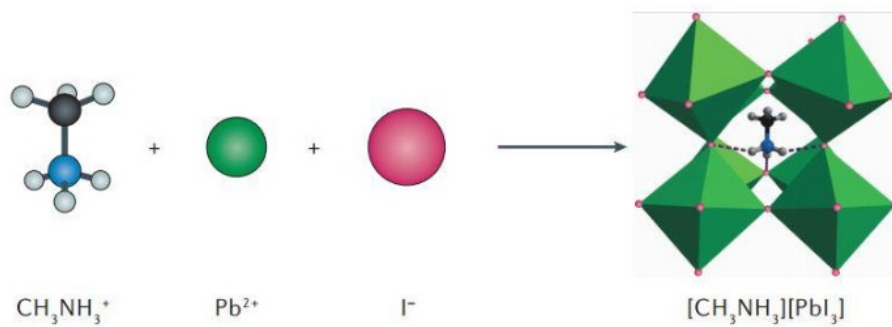

Figure 14. HOIP with an organic cation at the A-site, MAPbI_3 (orthorhombic, MA = methylammonium) [5]

Figure 2.14:

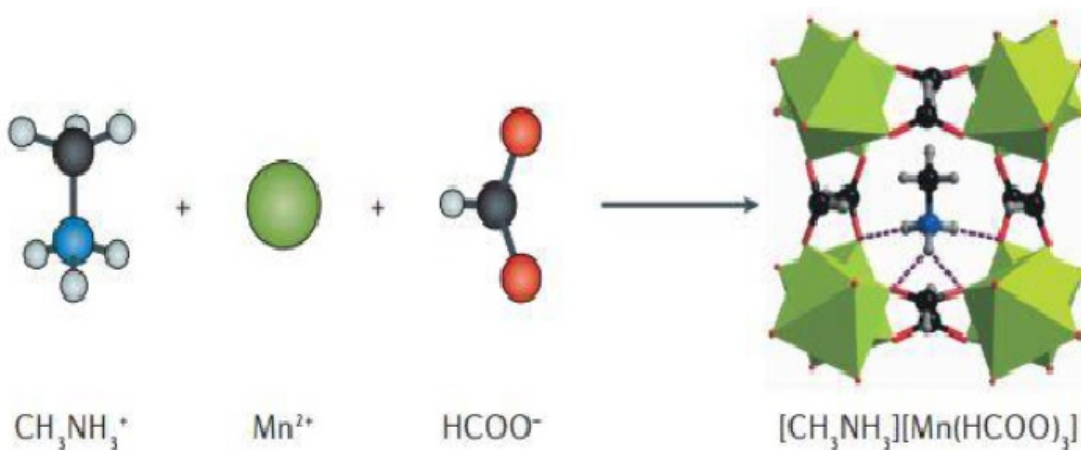

Figure 2.15: HOIP with an organic cation at the A-site and an organic anion at the X-site (a metal–organic framework perovskite), $[\text{MA}][\text{Mn}(\text{HCOO})_3]$ (orthorhombic). [5]

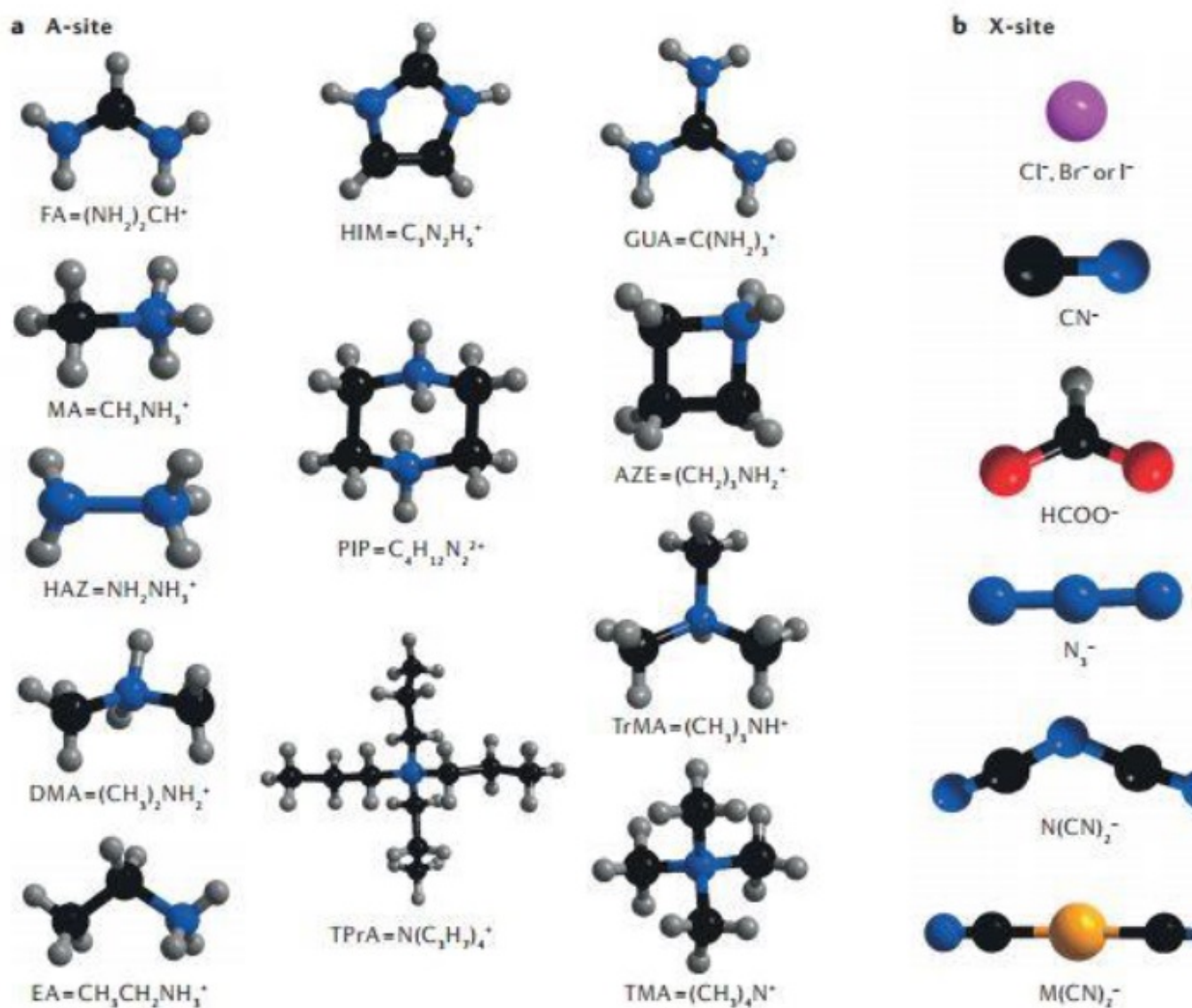

Figure 2.16: a) The structures of a selection of possible A-site cations used in (HOIPs); b) The structures of a selection of possible X-site anions used in HOIPs. [5] .

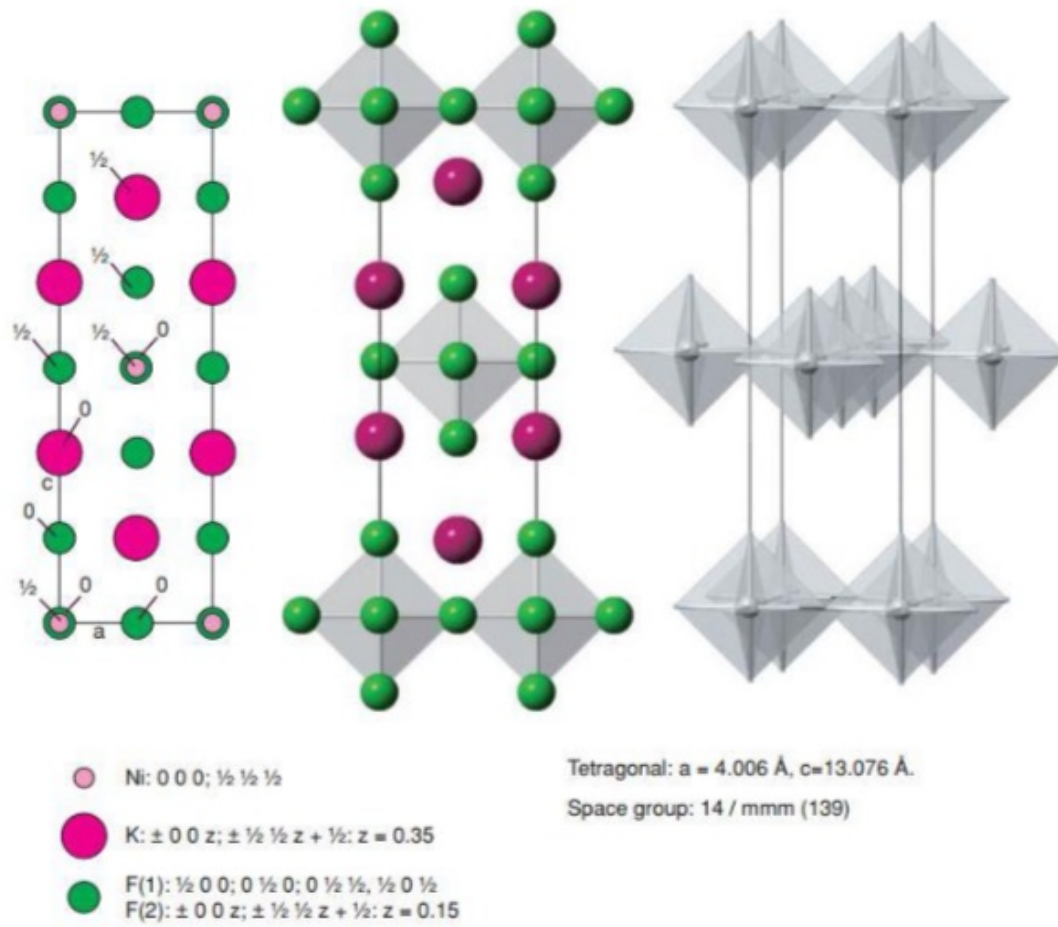

Figure 2.17: A_2BO_4 -Layered Perovskite: The K_2NiF_4 structure.[2]

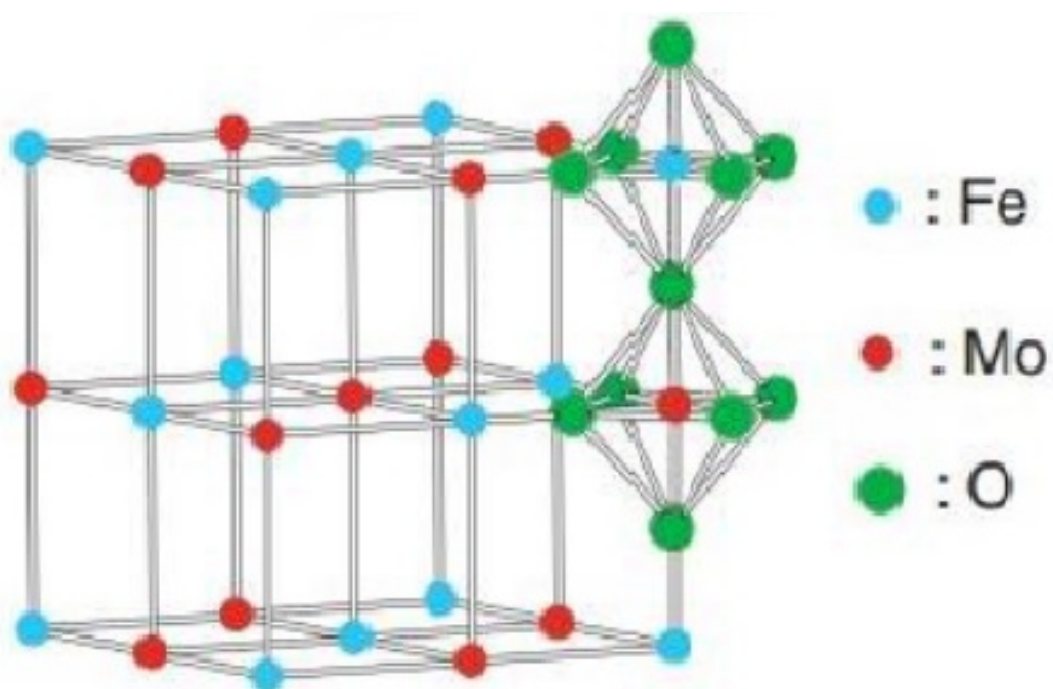

Figure 2.18: double perovskite $\text{A}_2\text{BB}'\text{O}_6$: The $\text{Sr}_2\text{FeMoO}_6$ structure.[6]

Chapter 3

SPECIAL APPLICATIONS OF PEROVSKITES

3.1 Perovskites in Magnetic Devices

Transition metal oxides of the perovskite ABO_3 materials have been an enticed area of material research for several decades in theoretical as well as application points of view owing to their intriguing physical properties such as superconductivity, multiferroicity, charge transfer, spin-dependent transport and colossal magnetoresistance along with their potential application in information storage, batteries, fuel cells spintronics and more [1-4]. Oxide-based heterostructures (crystallising in ABO_3 perovskite structure) opened receptive scope to a broader range of functionalities realised by changes in electron-lattice correlation modified by structural distortion, octahedral tilt, temperature, pressure and also as a consequent interplay between charge, orbital, spin and lattice degrees of freedom [5-10]. We present in this chapter a wide range of applications of perovskites from the magnetic device application point of view with a highlight on a fundamental understanding of the electronic and magnetic structure of the perovskite materials. We hope that the chapter will stimulate more interest in perovskites and help readers better understand some important scientific concepts which explain how perovskites took its place as promising candidate in magnetic device application.

3.2 Electronic Structure of Perovskites

To begin with, it is essential to understand the electronic structure of perovskites for better understanding of their application in magnetic devices. In the ABO_3 structure, the B site cation is responsible for numerous exciting phenomena as a consequence of strong electron interactions between the partially filled d-orbitals in the B site cations. Regardless of the specific structure variants in the perovskite structure, the B site cation is always surrounded by six nearest neighbour of oxygen anions. As one would expect, due to the Coulomb repulsion between the 'd' orbital electrons and the surrounding charges from oxygen, the energy of the d-orbital increases as the oxygen anions approach the B site cations. Thus, the crystal environment of such oxygen octahedra breaks the five-fold degenerate d-orbitals into two high energy e_g orbitals and three low energy t_{2g} orbitals. The deformation of the octahedral structures due to internal (Jahn-Teller distortion) or external (e.g. epitaxial strain) perturbation can lift the degeneracies between the e_g and t_{2g} orbitals further to reach an energy occupation configuration.

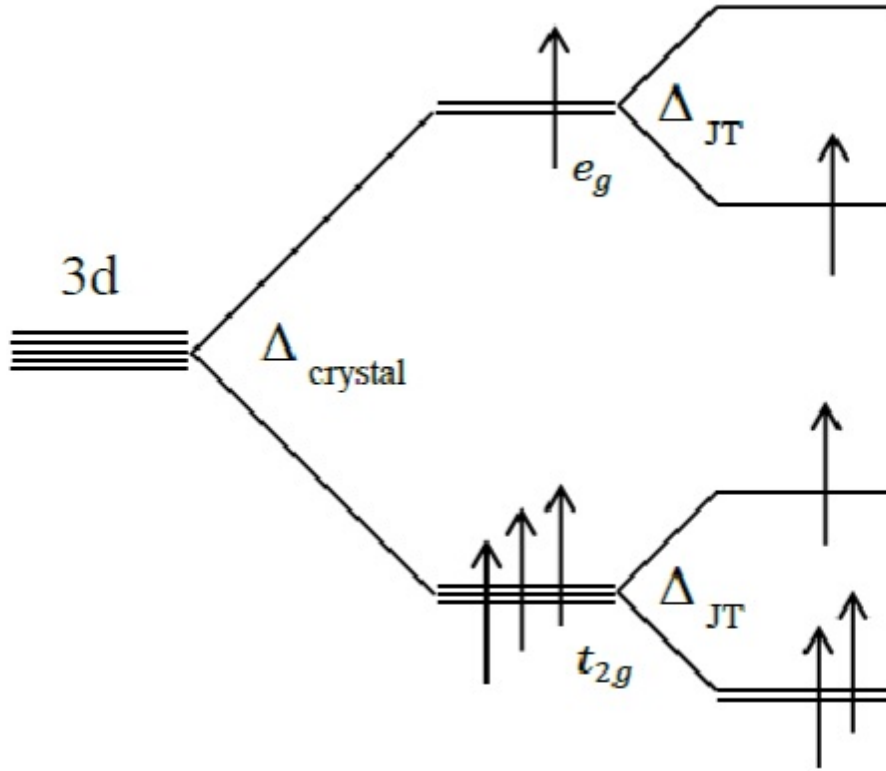

Figure 3.1: Schematic representation of crystal field splitting of five-fold degenerate atomic 3d-orbitals into d and e levels, further splitting due to Jahn-Teller (JT) distortions.

3.3 Perovskites in Magnetocaloric Effect Based Magnetic Refrigerators

Magnetic refrigeration is a cooling technology based on the magneto-caloric effect. This technique can be used to attain extremely low temperatures, as well as the ranges used in conventional refrigerators. The magneto-caloric effect (MCE) is an intrinsic property of all magnetic materials and is induced through the coupling of a spin system with a magnetic field. When a magnetic field is applied adiabatically to a magnetic material, the spins in the material are aligned parallel to the field. Due to the reduced magnetic entropy, the material warms up to offset the lost magnetic entropy through an increase of the lattice entropy. Upon removal of the magnetic field, the ensuing spin randomisation results in a rise of the magnetic entropy and a decrease of the lattice entropy (i.e. a drop in temperature). The magnetic refrigeration Carnot cycle cooling efficiency is 30-60% compared to 5-10% gas-compression refrigeration. Also, magnetic refrigeration is environmentally friendly as it does not use ozone-depleting or global warming gases. According to the Curie-Weiss law, ferromagnetic materials with a large effective Bohr magneton-number P ($P = g[J(J+1)]^{1/2}$, where g is the g factor, and J is the total angular momentum quantum number) are expected to have a substantial magnetic entropy change at the Curie temperature T_C . Given that, researchers of the previous studies mainly concentrated on intermetallic compounds and the alloys of rare earth metals with high J . In 1995 and 1996, anomalous thermal expansions were observed in perovskite-type ferromagnetic oxides at their Curie temperatures; some of them exhibited a sharp change of magnetisation and a discontinuous volume variation at the field. Due to the reduced magnetic entropy, the material warms up to offset the lost magnetic entropy through an increase of the lattice en-

tropy. Upon removal of the magnetic field, the ensuing spin randomization results in a rise of the magnetic entropy and a decrease of the lattice entropy (i.e. a drop-in temperature). The magnetic refrigeration Carnot cycle cooling efficiency is 30-60% compared to 5-10% gas compression refrigeration. Also, magnetic refrigeration is environmentally friendly as it does not use ozone-depleting or global warming gases. According to the Curie–Weiss law, ferromagnetic materials with a large effective Bohr magneton number P ($P = g[J(J + 1)]^{1/2}$, where g is the g factor, and J is the total angular momentum quantum number) are expected to have a substantial magnetic entropy change at the Curie temperature. Given that, researchers of the previous studies mainly concentrated on intermetallic compounds and the alloys of rare earth metals with high J . In 1995 and 1996, anomalous thermal expansions were observed in perovskite-type ferromagnetic oxides at their Curie temperatures; some of them exhibited a sharp change of magnetisation and a discontinuous volume variation at the ferromagnetic transition. The simultaneous structural and magnetic changes at T_C could have a strong influence on the magnetic entropy change [11]. Compared with the rare earth metals and their alloys, the perovskite type oxides exhibit a considerably smaller magnetic hysteresis, higher chemical stability, and a higher electrical resistivity that favours a lower value of eddy-current heating. In other words, the perovskite-type oxides appear to be more suitable candidates for magnetic refrigeration at high temperatures, especially near room temperature.

3.4 Perovskites in Spintronics

Spintronics is a conventional digital electronic system conveys a binary signal (think 1s and 0s) through pulses of electrons carried through a conductive wire. Spintronics can convey additional information via another characteristic of electrons, their spin direction (think up or down). Spin is related to magnetism. So spintronics uses magnetism to align electrons of a particular spin, or "inject" spin into a system. Because of heavy lead atoms in perovskite, physicists predicted that the mineral might possess strong "inject" spin into a system. Because of heavy lead atoms in perovskite, physicists predicted that the mineral might possess strong spin-orbit coupling. In a 2017 paper, Vardeny and Sarah Li showed that a class of perovskites called organic-inorganic hybrid perovskites do indeed possess large spin-orbit coupling. Also, the lifetime of spin injected into the hybrid materials lasted a relatively long time. Both results suggested that this kind of hybrid perovskite held promise as a spintronics material. The next step, which Vardeny and Wang accomplished in their recent work, was to incorporate hybrid perovskite into spintronic devices.

The first device is a spintronic light-emitting diode or LED. The semiconductor in a traditional LED contains electrons and holes, places in atoms where electrons should be but are not. When electrons flow through the diode, they fill the holes and emit light. Wang says that a spintronic LED works much the same way, but with a magnetic electrode, and with electron holes polarised to accommodate electrons of a particular spin. The LED lit up with circularly polarised electroluminescence, Wang says, showing that the magnetic electrode successfully transferred spin-polarised electrons into the material. "It is not self-evident that if you put a semiconductor and a ferromagnet together, you get a spin injection," Vardeny adds. "You have to prove it.

Moreover, they proved it. "The second device is a spin valve. Similar devices already exist and are used in devices such as computer hard drives. In a spin valve, an external magnetic field flips the polarity of magnetic materials in the valve between an open, low-resistance state and a closed, high-resistance state. Wang and Vardeny's spin valve do more. With hybrid

perovskite as the device material, the researchers can inject spin into the device and then cause the spin to precess, or wobble, within the device using magnetic manipulation. That is a big deal, the researchers say. "You can develop spintronics that are not only useful for recording information and data storage, but also calculation," Wang says. "That was an initial goal for the people who started the field of spintronics. and that is what we are still working on. "Taken together, these experiments show that perovskites works as a spintronic semiconductor. The ultimate goal of a spin-based transistor is still several steps away, but this study lays important groundwork for the path ahead. "What we have done is to prove that what people thought was possible with perovskite happens," Vardeny says. "That is a big step.

3.5 Perovskites in Data Storage System

With the advance of technology, the need for storage systems with higher density and efficiency increased, and this also requires materials with tunable magnetic properties in order to read and write data over them. EPFL scientists have developed a perovskite material whose magnetic order can be rapidly changed without disrupting it due to heating. The work, which describes the first ever magnetic photo-conductor, is published in Nature Communications. Magnetism in material arises from the interactions of localised and moving electrons of the material; in a way, it is the result of competition between different movements of electrons. This means that the resulting magnetic state is wired in the material and it cannot be reversed without changing the structure of electrons in the material's chemistry or crystal structure. However, an easy way to modify magnetic properties would be an enormous advantage in many applications, such as magnetic data storage. The new material that the EPFL scientists developed the first magnetic photo-conductor. This new crystal structure combines the advantages of both ferromagnets, whose magnetic moments are aligned in a well-defined order, and photo-conductors, where light illumination generates high density free conduction electrons. The combination of the two properties produced an entirely new phenomenon: the "melting" of magnetisation by photo-electrons, which are electrons that are emitted from a material when light hits it. In the new perovskite material, a simple red LED weaker than a laser pointer is enough to disrupt, or "melt" the material's magnetic order and generate a high density of traveling electrons which can be freely and continuously tuned by changing the light intensity. The time scale for shifting the magnetic in this material is very fast, virtually needing only quadrillionths of a second. Though still experimental, all these properties mean that the new material can be used to build the next generation of memory-storage systems, featuring higher capacities with low energy demands.

3.6 References

1. A. Ohtomo, H. Y. Hwang . A high-mobility electron gas at the LaAlO₃/SrTiO₃ heterointerface. *Nature* 427, 423–426 (2004).
2. M. N. Iliev, P. Padhan, and A. Gupta. Temperature-dependent Raman study of multiferroic Bi₂NiMnO₆ thin films. *Phys.Rev.B* 77, 172303 (2008).
3. Kai Lv, H. P. Zhu, W. Q. Zou, F. M. Zhang, and X. S. Wu, Charge transfer and orbital-reconstruction in the (La₂/3Sr₁/3MnO₃)_m/(SrRuO₃)_{nc} Superlattices. *J. Appl. Phys.* 117, 185305(2015).
4. Aamir Minhas Khan, Arif Mumtaz, Syed Khurshid Hasanain, Anwar Ul Haq. Low temperature magnetoresistive effects and coulomb blockade in La_{0.7}Ca_{0.3}MnO₃ nanoparticles

- synthesis by auto-ignition method. *Natural Science*. Vol.3, No.6, 496-501 (2011).
5. Elbio Dagotto. When Oxides Meet Face to Face *Science* 318 (5853), 1076-1077 (2007)
 6. Nico Homonnay, Kerry J. Oshea, Christian Eiseenschmidt, Martin Wahler, Donald A. MacLaren and Georg Schmidt. Interface Reactions in LSMO Metal Hybrid Structures. *Appl Mater. Interfaces*. **7**, 22196-22202 (2015).
 7. B. C. Behera, A. V. Ravindra, P. Padhan, and W. Prellier. Raman spectra and magnetization of all-ferromagnetic superlattices grown on (110) oriented SrTiO₃. *Appl. Phys. Lett.* 104, 092406(2014).
 8. P. Padhan, and W. Prellier. Size effect on magnetic coupling in all-ferromagnetic superlattices. *Appl. Phys. Lett.* 99, 263108 (2011).
 9. Sujit Das, Andreas Herklotz, Eckhard Pippel, Er Jia Guo, Diana Rata and Kathrin.D., Strain dependence of antiferromagnetic interface coupling in La_{0.70}Sr_{0.3}MnO₃/SrRuO₃ superlattices, *Phys.Rev.B*. **91**, 134405 (2015).
 10. B.C. Behera, P.Padhan , W.Prellier . Influence of substrate in all-ferromagnetic superlattices. *J Magn Magn Mater.* 22-27 388(2015)
 11. Zhong Wei, Au Chak-Tong, , and Du You-Wei . Review of magnetocaloric effect in perovskite type oxides. *Chin. Phys. B* Vol. 22, No. 5 ,057501(2013).

Chapter 4

HYBRID ORGANIC INORGANIC PEROVSKITES - AN INTRODUCTION

4.1 Introduction

The desire to surpass the efficiency of silicon in converting photon energy to electricity and thereby other useful chemicals has been pushing the scientists and engineers to find alternate materials not only to replace silicon (possibly due to cost considerations and processing methods) but also make the process of manufacture of these new materials in an easier way as compared to manufacture of single crystal silicon. In this exercise, lasting for more than 5 to 6 decades a new material has emerged in 2009, since then there is sudden raise in efficiency of perovskite based solar cells from 3.8% to nearly 22% which has stunned the photovoltaic community. This situation warrants attention not only from the point of view of increased efficiency but also the possibility of a number of new systems emerging due to the fact that a number of possibilities exist in the variation of composition in ABX_3 perovskite structure. Research on solar cell possibly started in 1839 with Alexandre Edmond Becquerel. In 1873, photo-conductivity was discovered in selenium by Willoughby Smith an English engineer. First solar cell was made by American inventor Charles Fritts based on selenium. In 1940, Bell laboratories started research on semiconductor based solar cells and patented a cell with 1% efficiency. In 1954, Bell laboratories demonstrated the first practical silicon based solar cells. In the similar way, the brief history of organic inorganic perovskites traces back to 1893. H.L. Wells first synthesized alkali metal tin and lead halides. In 1958, the chemical structure of perovskite caesium lead halide was determined by Christian Mueller. In 1978, Dieter Weber replaced trimethyl ammonium ion in the caesium lead halide to form a class of compounds called Hybrid Organic Inorganic Perovskites (HOIP). The optical and other properties of these new generation compounds have been examined since the last two decades and their application in solar cells started in 2009. The growth in solar cell efficiency is pictorially shown in Fig.1. This figure also gives the progress in efficiency of other solar cell materials like crystalline silicon, CdTe, Dye sensitized solar cells and quantum dots. Compared to other well-known Solar cell materials the efficiency of organic inorganic solar cells has reached a value of around 23% in a short span of less than a decade. The scope of generating newer materials for solar cell application among this class of organic inorganic perovskites appears to be great. This is demonstrated by Gregor Kiealich et al. [2]. They have used the concept of tolerance factor (conventionally known as Goldschmidt's tolerance factor) and applied to the permutations of 14 different protonated amines 8 different anionic species and 21 divalent metal ions generated 2352 tolerance factor (TF) values, out of these 742 had tolerance factor values in the range 0.8 to 1 (the limits of perovskite structure) out of which 140 are known materials and the remaining 562 are organic anion based. This study with limited number of organic cations shows that

there is still scope of finding suitable materials for solar cell application. This limited discussion on the possibility of generating many unknown materials with perovskite structure speaks volumes on the feasibility of generating new solar cell materials with the required efficiency in the near future.

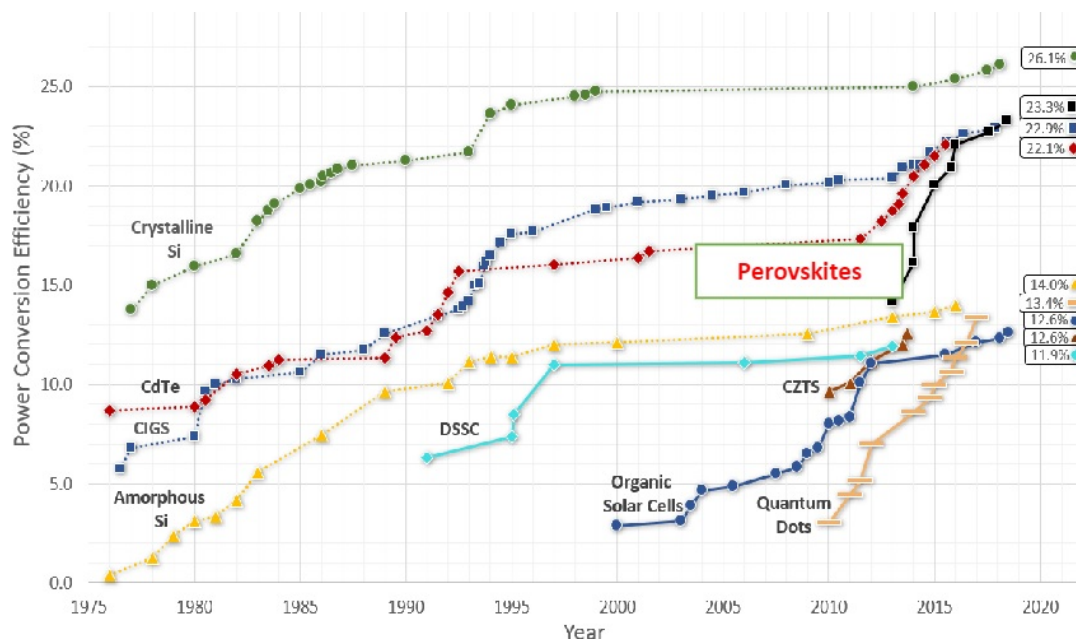

Figure 4.1: Values of the efficiency versus time plot for various (crystalline Silicon, CdTe, DSSC, organic solar cells). Perovskite solar cells have increased in power conversion efficiency at a phenomenal rate compared to other types of photovoltaics. [reproduced from Ref [1].

Fig.2 Illustrates the rapid increase in the efficiency of perovskite solar cells. The increase achieved in the past decade is remarkable. The cells have already achieved documented efficiencies of the order of greater than 23%, which represents an unprecedented rate of progress compared to any other solar cell technology. For comparison the rate of increase of efficiency for other typical solar cells are also shown for a chosen typical solar cell. OPV stands for organic photovoltaics; DSSC means dye-sensitized solar cell; A-Si stands for amorphous Si solar cell; Efficiency denotes solar to electrical power conversion efficiency of the best cells at that time [reproduced from ref.7].

In the synthesis of HOIP, the pioneering work was done by Schmidt et al [3]. This team synthesized HOIP by injecting methyl ammonium bromide and lead bromide solutions into a preheated reaction medium oleic acid and octyl ammonium bromide dissolved in octadecene. The particles are Perovskites precipitated by adding acetone. Zhang et al. [4] have developed a ligand assisted re-precipitation approach for preparing methylammonium lead halide nanoparticles. The synthesis procedure involves step-wise injection of a solution of the precursors in DMF and precipitation in toluene. Fig.1b Typical solar cell efficiency for chosen systems with respect to the period. [reproduced from ref.7]. Vapour assisted solution process consists of crystallization of metal halide coated substrate which is spin coated before hand into a methyl ammonium iodide vapour filled environment. This synthesis procedure was adopted to get a material which originally gave an efficiency of 12.1% [5]. Though in the initial stages of the precipitation of the precursors, the perovskite framework is formed, its growth and the conditions under which various architectures are evolved and the role of impurities in the formation of nucleus and growth are not well documented in literature [6]. Even though low temperature

Evolution of hybrid I-O Perovskite solar cells

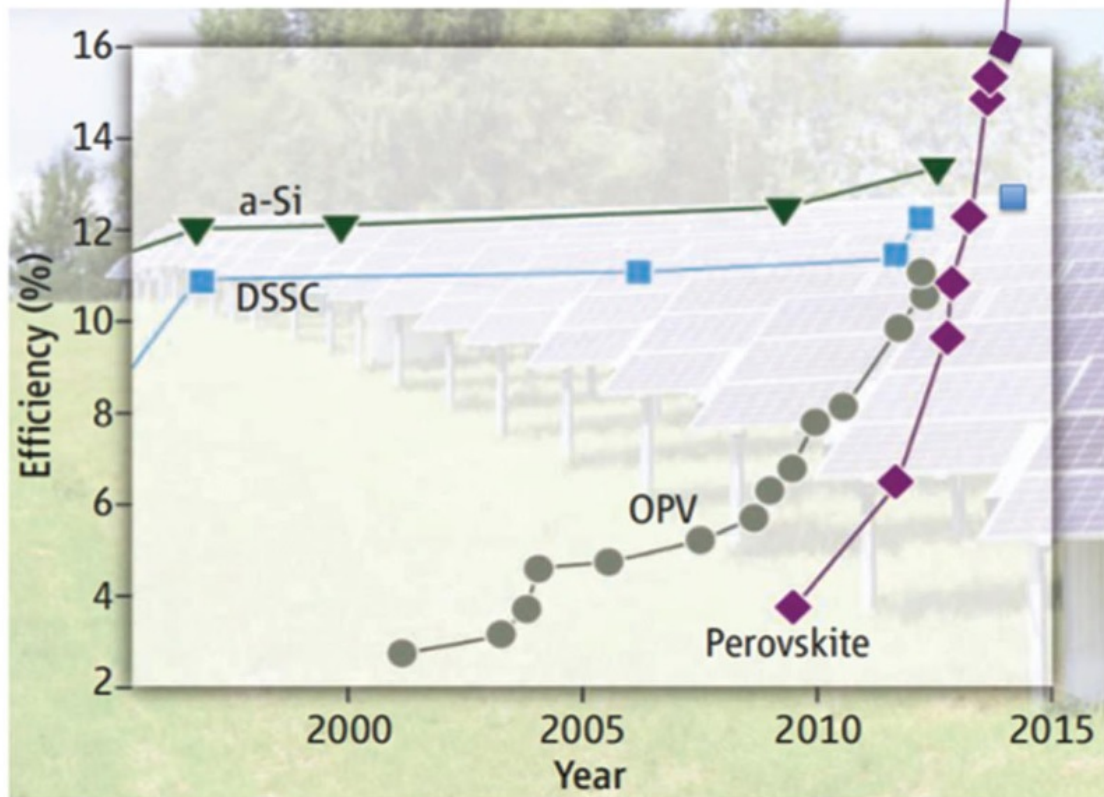

Figure 4.2: Fig.1b Typical solar cell efficiency for chosen systems with respect to the period. [reproduced from reference 7]

solution phase methods are applicable for preparation of these materials, their stability and optical properties are still to be improved and it is hoped considerable progress in these directions will take place in the near future.

Table 1. Transport characteristics of HOIPs and their comparisons with those characteristics of other semiconductors

HOIPs are softer mechanically as compared to other efficient solar cell materials. What does this imply? HOIPs are susceptible for many facile phase transitions (in this sense these are dynamic materials) inducing migration of intrinsic and extrinsic ionic species. These fluctuations and long-range ionic motions have strong impact on charge transport and optical properties. Perovskite structure is usually adopted by ABO_3 types of oxide materials. Hybrid organic inorganic perovskites with the composition ABX_3 where A and B are mono and bivalent cations and X can be monovalent anion and A cation is an organic component.

4.2 References

1. <https://www.ossila.com/pages/perovskites-and-perovskite-solar-cells-an-introduction>.
2. Gregir Kieslich, Shijing Sun and A.K.Cheetham, An extended Tolerance factor approach-

Table 4.1: Material characteristics of perovskite and semiconductor materials

Material	Diffusion length (μm)	Carrier life time (μs)	Mobility ($\text{cm}^2\text{V}^{-1}\text{s}^{-1}$)	Effective mass(m_0)	Trap density (cm^{-3})
$\text{CH}_3\text{NH}_3\text{PbI}_3$ (polycrystalline film)	0.01-1	0.01-1	1-10	0.015	10^{15} - 10^{16}
$\text{CH}_3\text{NH}_3\text{PbI}_3$ (single crystal)	2-8	0.5-1	24-105	-	$(1 - 3) \times 10^{16}$
$\text{CH}_3\text{NH}_3\text{PbBr}_3$ (polycrystalline film)	0.3-1	0.05-0.16	30	0.13	-
$\text{CH}_3\text{NH}_3\text{PbBr}_3$ (single crystal)	3-17	0.3-1	24-115	-	$(0.3 - 6) \times 10^{10}$
Silicon (e^-h^+)	1-600	1000	1450-500	0.1-0.16	10^5 - 10^{15}
GaAs (e^-h^+)	7-1.6	0.1-1.0	8000-400	0.063-0.076	-

Table 4.2: Structural phase transitions for commonly employed hybrid perovskites

Composition	Phase	Temp (K)	Structure	Space group	Band gap (eV)	Volume (\AA^3)
MAPbI_3	Alpha	400	Tetragonal	P4mm	1.51-1.55	251.6
	Beta	293	Tetragonal	I4m	-	900
	Gamma	162-172	Orthorhombic	Pna2	-	959.6
MAPbCl_3	Alpha	178.8	Cubic Pm3m	-	-	182.2
	Beta	172.9-178.8	Tetragonal	P4/mmm	-	180
	Gamma	172.9	Orthorhombic	P222	-	375
MAPbBr_3	Alpha	236.9	Cubic Pm3m	-	-	286.3
	Beta	155.1	Tetragonal	I4/m	-	819.4
	Gamma	144.5	Tetragonal	P4/mmm	-	811.1
MASnI_3	Alpha	293	Tetragonal	P4mm	-	241.9
	Beta	200	Tetragonal	I4/m	-	952.1
FAPbI_3	Alpha	293	Tetragonal	P2m	1.43-1.48	748.9
	Beta	150	Tetragonal	P3	-	2988.4
FASnI_3	Alpha	340	Orthorhombic	Amm2	-	509.03
	Beta	180	Orthorhombic	Imm2	-	1959.2

skites, organic-inorganic perovskites, Chem.Sci., 6, 3430 (2015).

3. Schmidt L.C., Pretegas, A., Gonzalez-Crroero,S., Malinkiewicz, re O., Agouram,S.,Espallargas,G.M., Bolin,H.J., Galian,B.E., Perez-Prieto,J., J.Am.Chem.Soc., 136, 850(2014).

4. Zhang,F., Zhong,H., Chen,X.C., Wu,H., Huang,J., Han,B., Zou,Y., Dong, ACS Nano,9,4533 (2015).

5. Thomas, M. Brenner, David A.Egger, Lecor Kronik, Cary Hodes, and David Cahen, HybridOrganic-Inorganic perovskites low-cost semiconductors with intriguing charge transport-properties, Nature reviews,1, 1-6 (2016).

6. Qi Chen, Nicholas De Marco, Yang (Michael) Yang, Tze-Bin Song, Z.Hong, Chun ChaoChen, H.Zhao, Z.Hong, H.Zhou, Yang Yang, Under the spotlight: The organic-inorganichybrid halide perovskite for optoelectronic applications, Nano Today, 10,355 (2015)

7. Joseph Berry , Tonio Buonassisi , David A. Egger , Gary Hodes , Leeor Kronik , Yueh-LinLoo, Igor Lubomirsky Seth R. Marder , Yitzhak Mastai , Joel S. Miller , David B. Mitzi,Yaron Paz, Andrew M. Rappe , Ilan Riess , Boris Rybtchinski , Oscar Stafsudd , VladanStevanovic , Michael F. Toney , David Zitoun , Antoine Kahn , David Ginley ,and DavidCahen, Hybrid Organic-Inorganic Perovskites (HOIPs): Opportunities and Challenges,Adv. Mater. 2015, 27,

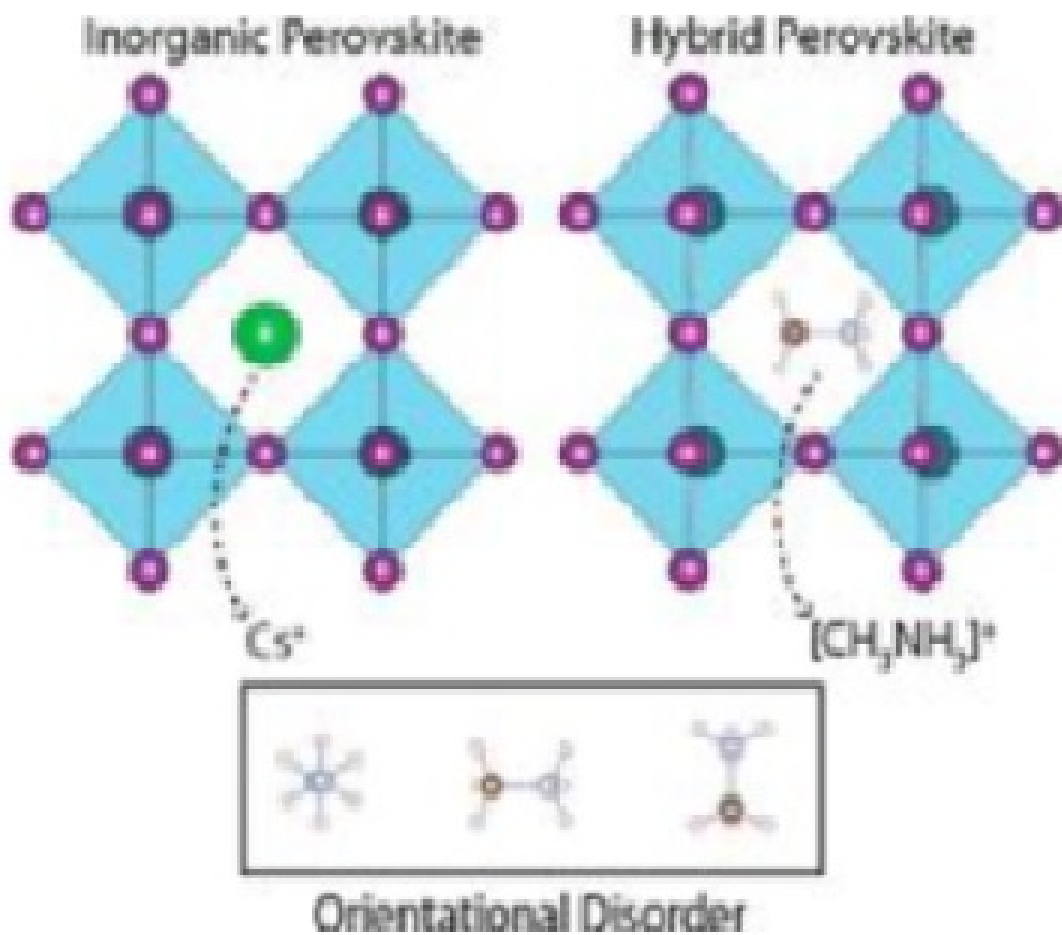

Figure 4.3: Orientational disorder associated with the non-spherically symmetric organic methylammonium [(CH₃NH₃)] cation as compared to the spherically symmetric inorganic cation [Reproduced from reference 6]

5102–5112

Chapter 5

PERSPECTIVES ON PEROVSKITES

5.1 Perovskite Solar Cells

The science of perovskite materials is at crossroads since, in many applications like solar cells, they are competing with the already established high-performance materials. The current situation on these materials is reflected from the number of high impact scientific publications in various journals and also the establishment of the perovskite-info weekly newsletter. This situation is mainly due to the possibility of generating innumerable compositions with this structure. This situation today warrants a selection based on thousands (even millions) of possibilities, and hence one has to resort to some predictions based on computer-based screening of materials. This is reflected in the recent publications on this topic [1]. Designing new functional materials has always been a challenge since the conventional methods are ineffective when one has to screen thousands of potential materials [2,3].

There are empirical methods (like tolerance factor) that have been commonly employed to predict the formation of the perovskite phase. However, it must be stated that there are limitations to this method, especially for hybrid systems. This aspect has been dealt with in earlier chapters. The synthesis methodologies adopted for forming perovskite phases are simple and straight forward like solid-state reaction, complex decomposition or co-precipitation, and so on. These methods generally yield the perovskite phase as identified by the X-ray diffraction method.

The versatility of perovskites arises from the geometry of the crystal structure and the ionic radii of the constituent ions. The electronic configuration of the various ions is mainly responsible for the observed electrical and magnetic and dielectric property of the perovskite systems. One of the applications where perovskites are threatening to replace almost all other alternatives is the exploitation of their opto-electronic property, and hence, they are today considered as the materials for solar cells. The progress in this application of these materials has been dealt with in the earlier chapters. The rapid progress in this field is again traced in the following figure

Despite this rapid development, some critical factors appear to restrict this unusually rapid development of perovskite-based solar cells [4,5]. These can be listed as follows:

- The stability especially of the organic lead halide perovskites is greatly affected by environmental factors (like humidity, temperature, and radiation), which lead to the low stability of the devices and the great difficulties in encapsulating cells. To specify the exact composition of the device and also to package the layers for the charge transport will be necessary for the practical application of these devices.
- The hole transporting material employed in perovskite-based solar cells is expensive, and its synthesis procedure is complicated. Therefore, it is necessary to find alternate hole transport materials to adapt to the commercial applications of perovskite solar cells

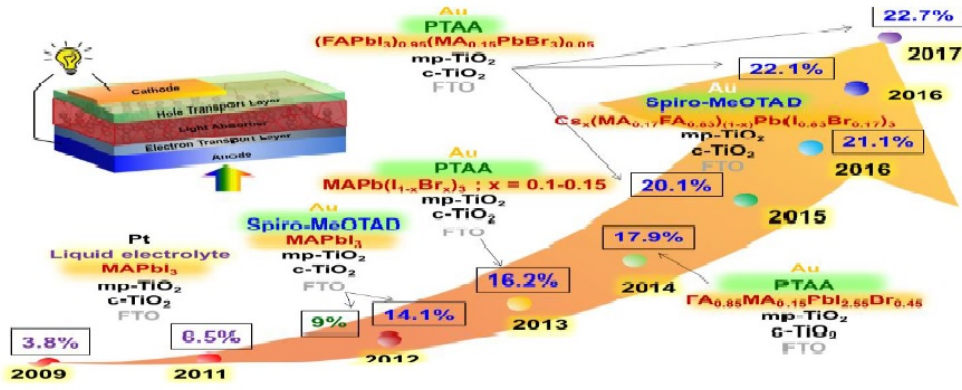

Figure 5.1: The graphical representation of the year-wise evolution of the efficiency of perovskite based solar cells. The figures in blue are the certified efficiencies by NREL. [Figure reproduced from reference 6]

- Technologically obtaining large area perovskite films with the available traditional methods is difficult. There is a need to improve these deposition methods for commercial production in the future.
- The elements involved (especially Pb) employed in perovskite solar cells is toxic, which will come in the way of industrial production and promotion of this technology. Various alternatives have been proposed and being tested including double perovskites [7,8,9]
- The understanding of the microscopic mechanism of perovskite solar cells has not reached the desired levels. This aspect has to be carefully looked into so that further improvements in performance and new materials can be formulated.

The progress in the value of the efficiency of perovskite solar cells is impressive, but the issue of instability has attracted enormous attention. For the commercialisation of perovskite-based solar cells, instability of the fabricated device is the main barrier that has to be surmounted. There is a considerable improvement in the stability of perovskites. Still, it has to be improved considerably. Structural design, charge transport materials, encapsulation methods have to be improved [10,11]. The replacing the poisonous lead has been attempted by applying Goldschmidt's rule and also quantum mechanical calculations and this methodology has been used for the development of photovoltaics. It is interesting to pay attention to the opto-electronic properties of the lead-free materials to provide environmentally friendly devices. This methodology has to be improved further [12]. The factors namely low cost, large area, high throughput, high solar-to-energy, reproducibility long lifetime and toxicity have to be optimized for these photovoltaic devices to industrial scale applications. [13]. There are various aspects wherein the improvements are essential, and leading experts have discussed these in recent times. [14-18]. These can be identified as thermal stability, grain boundary defects, the stoichiometry of the phases, the hysteresis of the materials, and also moisture stability, and all these aspects have to

be carefully overcome so that commercialization of the technology will prove fruitful. There is considerable progress in identifying the cause of these shortcomings, and how to overcome them but still more research efforts have to be expanded in order to make these materials suitable for commercial applications.

Bibliography

- [1] Gregir Kieslich, Shijing Sun and A.K.Cheetham, An extended Tolerance factor approach for organic-inorganic perovskites. *Chem. Sci.*, 6, 3430 (2015).
- [2] Shuaihua Lu, Qionghua Zhou, Yixin Ouyang, Yilv Guo, Qiang Li, and Jinlan Wang, Accelerated discovery of stable lead-free hybrid organic-inorganic perovskites via machine learning, *Nat. Commun.*, 9, 3405 (2018).
- [3] Chiho Kin, Tran Doan Huan, Sridevi Krishnan and Rampi Ramprasad, A hybrid organic-inorganic perovskite dataset, *Sci. Data*, 4, 170057 (2017).
- [4] Berry J, Buonassisi T, Egger DA, Hodes G, Kronik L, Loo YL, Lubomirsky I, Marder SR, Mastai Y, Miller JS, Mitzi DB, Paz Y, Rappe AM, Riess I, Rytchinski B, Stafsudd O, Stevanovic V, Toney MF, Zitoun D, Kahn A, Ginley D, Cahen D, Hybrid Organic-Inorganic Perovskites (HOIPs): Opportunities and Challenges, *Adv. Mater.*, 27(35), 5102-12 (2015).
- [5] Di Zhou, Tiantian Zhou, Yu Tian, Xiaolong Zhu, and Yafang Tu, Perovskite-Based Solar Cells: Materials, Methods, and Future Perspectives, *J. Nanomater.*, Volume 2018, Article ID 8148072, 15 pages.
- [6] Luis K Ono and Yabing Qi, Research progress on organic-inorganic halide perovskite materials and solar cells, *J. Phys. D: Appl. Phys.*, 51 (2018) 093001 (27pp).
- [7] Nitin Labhassetwar, Govindachetty Saravanan, Suresh Kumar Megarajan, Nilesh Manwar, Rohini Khobragade, Pradeep Doggali and Fabien Grasset, Perovskite-type catalytic materials for environmental applications, *Sci. Technol. Adv. Mater.*, 16 (2015) 036002.
- [8] Zhengqi Shi and Ahalapitiya H. Jayatissa, Perovskites-Based Solar Cells: A Review of Recent Progress, Materials and Processing Methods, *Materials (Basel)*, 11(5): 729 (2018).
- [9] M. Pazoki and T. Edvinsson, Metal replacement in perovskite solar cell materials: chemical bonding effects and optoelectronic properties, *Sustain. Energy Fuels*, 2, 1430 (2018).
- [10] Liang Chu, Waqar Ahmad, Wei Liu, Jian Yang, Rui Zhang, Yan Sun, Jianping Yang, Xing'ao Li, Lead-Free Halide Double Perovskite Materials: A New Superstar Toward Green and Stable Optoelectronic Applications, *Nano-Micro Lett.*, 11:16 (2019).
- [11] Rui Wang, M. Mujshif, Yu Duan, Zhao-Kui Wang, Jingjing Xue and Yang Yang, Review of Perovskites Solar Cell Stability, *Adv. Funct. Mater.*, 2019, 1808843.
- [12] Ajay Kumar Jena, Ashish Kulkarni, and Tsutomu Miyasaka, Halide Perovskite Photovoltaics: Background, Status, and Future Prospects, *Chem. Rev.*, 119, 3036 (2019).
- [13] Hilal Ahmad Reshi and Rayees Ahmad Zargar, Recent Development in Optoelectronic Devices, Chapter 7, *IntechOpen*, (2018).

- [14] Longbin Qiu, K. Ono and Yabing Qi, Advances and challenges to the commercialization of organic-inorganic halide perovskite solar cell technology, *Materials Today Energy*, 7, 169 (2008).
- [15] <https://www.advancedsciencenews.com/perovskite-perspectives-henry-snaith-and-zhiping>
- [16] <https://www.advancedsciencenews.com/perovskite-perspectives-weiguang-xie-and-jianbin>
- [17] <https://www.advancedsciencenews.com/perovskite-perspectives-jingbi-stoichiometry-bet>
- [18] <https://www.advancedsciencenews.com/perovskite-perspectives-yi-hou-christoph-brabec>
- [19] <https://www.advancedsciencenews.com/perovskite-perspectives-chul-ho-lee-min-jae-ko>

Chapter 6

HYBRID PEROVSKITES - SOLAR CELLS

6.1 Introduction

Perovskites hold promise for creating solar panels that could be easily deposited onto most surfaces, including flexible and textured ones. These materials would be lightweight, cheap to produce, and as efficient as today's leading photovoltaic materials, which are mainly based on silicon. The term perovskite refers to a class of materials not like Si or CdTe which are single materials and other contenders in the photovoltaic domain.. The original mineral perovskite, calcium titanium oxide (CaTiO_3), has a distinctive crystal configuration. The family of perovskites consists of the many possible combinations of elements or molecules that can occupy each of the three components (A, B, or X) and form a structure similar to that of the original perovskite. "You can mix and match atoms and molecules into the structure, with some limits. For instance, if you try to stuff a molecule that's too big into the structure, you'll distort it. Eventually you might cause the 3D crystal to separate into a 2D layered structure, or lose ordered structure entirely," says Tonio Buonassisi, Professor of Mechanical Engineering at MIT and director of the Photovoltaics Research Laboratory. "Perovskites are highly tunable, like a build-your-own-adventure type of crystal structure," he says. Within the overall category of perovskites, there are a number of types, including metal oxide perovskites, which have found applications in catalysis and in energy storage and conversion, such as in fuel cells and metal-air batteries. But a main focus of research activity for more than a decade has been on lead halide perovskites, according to Buonassisi says. Many teams have also focused on variations that eliminate the use of lead, to avoid its environmental impact. Buonassisi notes, however, that "consistently over time, the lead-based devices continue to improve in their performance, and none of the other compositions got close in terms of electronic performance.". Searching for promising new candidate compositions for perovskites has seen many approaches including machine learning system.. While perovskites continue to show great promise, and several companies are already gearing up to begin some commercial production, durability remains the biggest obstacle they face. While silicon solar panels retain up to 90 percent of their power output after 25 years, perovskites degrade faster. Great progress has been made in this direction. From a research perspective, Buonassisi says, one advantage of perovskites is that they are relatively easy to make in the lab — the chemical constituents assemble readily. But that is also their downside: "The material goes together very easily at room temperature," he says, "but it also comes apart very easily at room temperature. Easy come, easy go!" To deal with that issue, most researchers are focused on using various kinds of protective materials to encapsulate the perovskite, protecting it from exposure to air and moisture. But others are studying the exact mechanisms that lead to that degradation, in hopes of finding formulations or treat-

ments that are more inherently robust. Buonassisi and his co-researchers recently completed an investigation showing that once perovskites reach a usable lifetime of at least a decade, thanks to their much lower initial cost that would be sufficient to make them economically viable as a substitute for silicon in large, utility-scale solar farms. Overall, progress in the development of perovskites has been impressive and encouraging, he says. With just a few years of work, it has already achieved efficiencies comparable to levels that cadmium telluride (CdTe), “which has been around for much longer, is still struggling to achieve,” he says. “The ease with which these higher performances are reached in this new material are almost stupefying.” Comparing the amount of research time spent to achieve a 1 percent improvement in efficiency, he says, the progress on perovskites has been somewhere between 100 and 1,000 times faster than that on CdTe. “That’s one of the reasons it’s so exciting,” he says.

The search for alternate energy conversion devices instead of using conventional fuels like fossil fuels, coal and other non-renewable sources has been more intense in the last decade and half. The extensive utilization of the inexhaustible source of sun’s energy has been a dream source for many centuries though the extent of its utilization has always been small percentage. The anxiety has been increasing slowly, but from 2010 on wards, the concept of Solar Cells (devices which convert radiation into electricity directly) has assumed importance especially after the introduction of silicon based solar cells were introduced. Even though many varieties of solar cells have been proposed, cost and conversion efficiency are the factors that have been the main concern. The desire to compete with silicon based solar cells (nearly 26%) in terms of conversion efficiency, Perovskite based solar cells (with conversion efficiency already achieved around 22%) are proposed as alternate choice materials.

Perovskites, is named after the Russian mineralogist L. A. Perovski, with the general formula ABX_3 (X = oxygen or halogen). The larger A cation occupies a cubo-octahedral site common with twelve X anions, the modest B cation is balanced out in an octahedral site with six X anions. The structure of a typical unit cell of perovskite is shown in Fig.1.

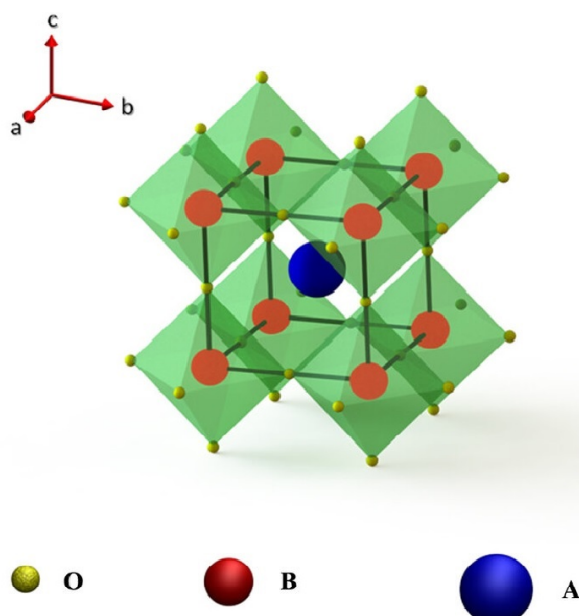

Figure 6.1: A typical Unit cell of Perovskite Structure

In general, photovoltaic performance of the perovskite solar cells is associated with their intrinsic properties like high absorption coefficient, tunable band gap, large carrier diffusion length, ambipolar carrier-transport ability and carrier mobility. The anxiety to make use of a

variety of perovskites, a new concept was introduced namely hybrid perovskite (OHIP), where A cation is an organic moiety like methylammonium (MA^+ , CH_3NH_3), formamidinium (FA^+ , $\text{CH}_3\text{CH}_2\text{NH}_3$), while the B cation is the conventional inorganic cations like Sn^{2+} , Pb^{4+} and X anions are usual halide ions. A simple pictorial representation of this hybrid system is shown in Fig.2.

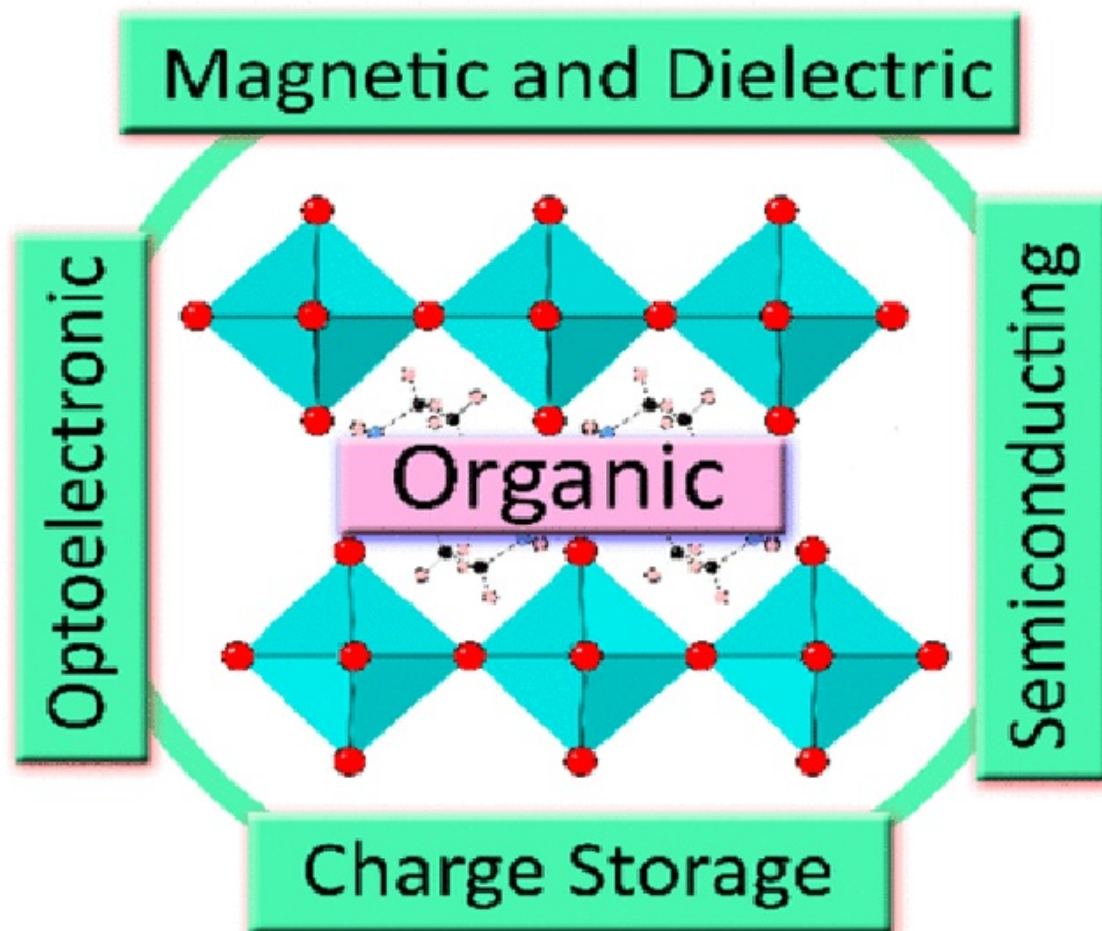

Figure 6.2: A pictorial representation of HOIP and their main properties and functions, The new properties result as a combination of two components

Further, in comparison to simple organic and inorganic semiconductors, the organic-inorganic hybrid perovskites exhibit unique optical and electrical properties. based on the concept of tolerance factor (see below) there have been attempts to predict various types of hybrid perovskites. One such attempt was made by Cheetham et al.[4] who have calculated the value of tolerance factor for over 2500 (for over 2500 prospective organic cation/metal halide-based anion ABX_3) compounds and determined that over 700 have a consistent tolerance factor with the perovskite structure, with more than 600 of these being unknown hypothetical compounds as of 2015.. It is important to note that the concept of tolerance factor for ionic radii represents a necessary condition for the perovskite structure, and it has had significant success in predicting new perovskite structures; however, other space-filling considerations also need to be considered.

In addition, these OHIP materials consists of large Bohr radius, weak binding energy, high dielectric constant, high carrier diffusion velocity and diffusion length along with outstanding light absorbing capacity. Owing to all these advantages, the OHIP materials became the candidates for fabricating efficient solar cells with low cost. Normally, the perovskite solar cells consist

an absorber layer (for example: $\text{CH}_3\text{NH}_3\text{PbX}_3$), which is inserted between electron-transport layer (ETL) and hole-transport layer (HTL). When the perovskite-absorber is subjected to light it inserts an electron and hole into n-type and p-type carrier transporting materials in order to generate free charge carriers. The energy-levels and charge-transfer process the path for the charge carriers of perovskite solar cells are digramatically shown in Fig. 3. This means that the solar cells have to be made in a designed fashion with several layers stacked one above the other. This fabrication aspect will be taken up subsequently.

Few words on the HTL and ETL will be in order at this stage.

6.2 Hole Transport Layer:

Electron-blocking materials are used as hole transportation materials in Perovskite Soolar cells (PSCs). The hole transport layer (HTL) assists in injecting the hole from the perovskite active layer and transfers the injected hole to the back electrode. The hole-transport layer also works as an electron-blocking layer that prevents electron flow The typical hole transport layers are, Spiro-OMeTAD (2,20,7,70-tetrakis-(N,N-di-p-methoxyphenylamine)-9,90-spiro-biurene), P3HT (Poly(3-hexylthiophene -2,5-diyl)), CuI-(Copper(I) iodide), CuSCN (Copper(I) thiocyanate), and so on.

6.3 Electron Transport Layer:

The layer that assists the injected electrons from the perovskite active layer to the front electrode is ETLs in the PSCs. The electron-transport layer also works as a hole-blocking layer that prevents the release of the holes to the front electrode, respectively. The typical electron transport layer is ZnO (Zinc Oxide), TiO_2 (Titanium Dioxide), SnO_2 (Tin (IV) oxide), IGZO (Indium-gallium-zinc oxide), PCBM (6,6-phenyl-C61-butyric acid methyl ester), and so on.

There are various aspects to be considered for the choice of ETL [Elelctron Transporting Layer] and HTL [Hole Transporting Layer] materials for increasing the efficiency of solar cells. The materials must be defect free (to decrease or eliminate charge recombination centres), thin nature (to increase photon absorption and performance), adding dopants to increase carrier mobility (conductivity and charge transfer), altering the morphology,(surface roughness and grain size) multiple growth methods and these have also been suggested for improved performance of solar cells.

The selection of suitable electrode materials (anode and cathode) should be based on the energy positions so that the carrier transport is a facile process.This condition is shown pictorially in Fig.3.

When sunlight strikes a PSC [Perovskite Solar Cells], the perovskite material absorbes photon, excitons are formed, and charge transporters (electrons and holes) are formed upon exciton parting. Exciton parting occurs at the boundary between the charge-transporting layer and perovskite film. After the electron is detached from the hole and inserted into the Electron Transporting Layer (ETL), it travels to the anode usually made of fluorine doped tin oxide (FTO) glass. Instantaneously, the hole is inserted into the HTL and afferwards travels to the cathode (typically a metal).The holes and electrons are collected by counter and working electrodes, separately and moved to the outward circuit to generate current. This is the common general principle of typical solar cells. The steps involved can be listed as follows:

- Photon absorption trailed by the generation of free charge
- Transport of charge

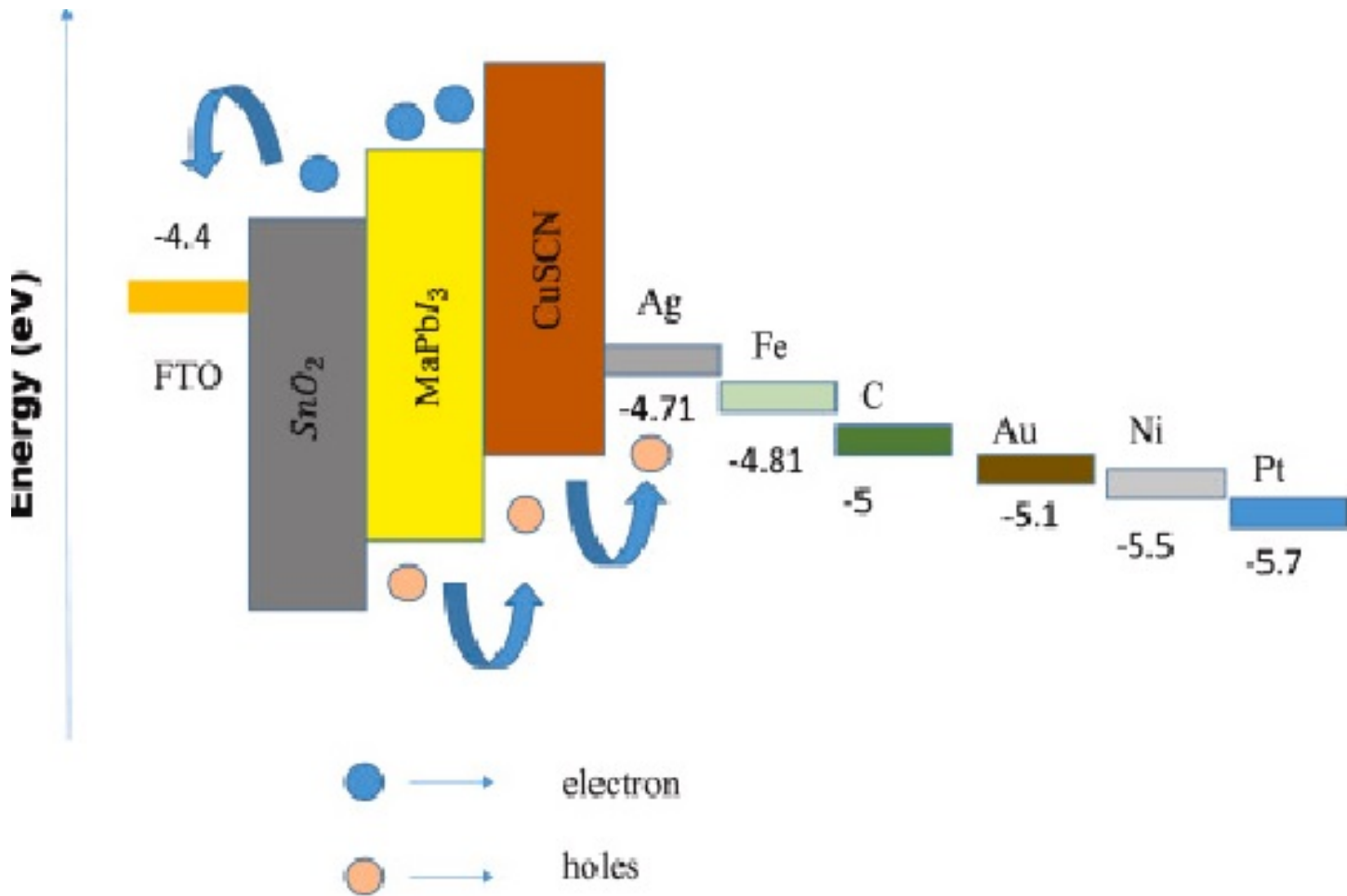

Figure 6.3: The different anodes and cathodes with their values of the work functions. Metals with different work function helps in tuning the magnitude and direction of electric field for better movement of light generated charge carriers.

- Extraction of charge

The structure adopted by ions and species depends on their radii and rigidity. Two critical factors for crystallizing in a perovskite structure are the octahedral factor (coordination factor) and the tolerance factor. The tolerance factor, defined as the ratio of bond lengths A–X to B–X in a perfect solid-sphere model, is scientifically expressed as:

$$(R_A + R_X) = t\sqrt{2}(R_B + R_X)$$

where R_A , R_B , and R_X are the ionic radii of corresponding ions. The tolerance factor t must satisfy $0.8 \leq t \leq 1.0$ for 3D perovskites. This concept has been discussed in earlier chapters. Lower values of t result in less symmetric tetragonal or orthorhombic structures, while values of t greater than 1 could destabilize the 3D B–X system.

For simple elemental inorganic ions, assigning an ionic radius is straightforward. However, molecular ions used in HIOPs (Hybrid Inorganic-Organic Perovskites) pose limitations due to potential free rotation around their center of mass. Ionic radii of some organic cations found at the A site are listed in Table 1, based on values reported by Kieslich et al. [4] or Becher et al. [19].

In Table 1, the values that are normally associated with these type of ions are assembled. The choice of the two cations A and B depends on the anion and if the anion is a halide ion

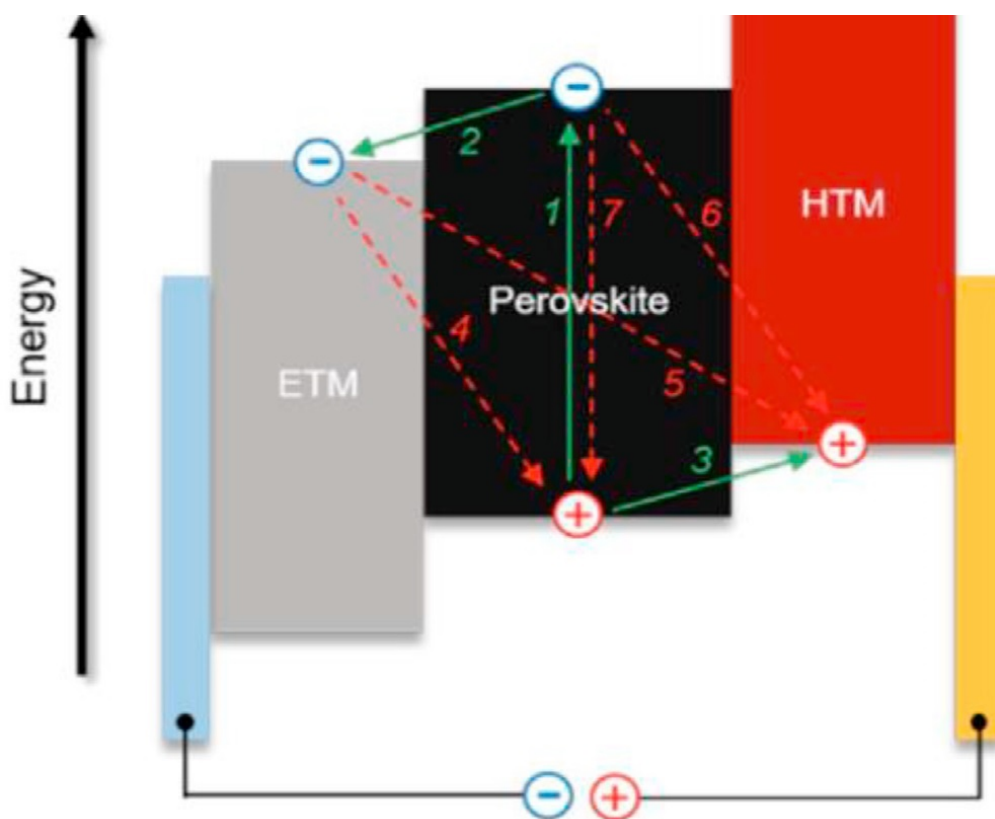

Figure 6.4: The electron and hole paths. Reproduced from Ameen S, Akhtar MS, Shin H-S, Nazeeruddin MK. Charge-transporting materials for perovskite solar cells. *Adv Inorg Chem* 2018:185e246. doi.org/10.1016/bs.adioch.2018.05.009

A must be univalent cation and B can be a divalent cation. In general, it must be ensured that the total cationic charge can compensate for the total anionic charge. For example two B cations with charge +1 and +3 can be equally substituted in the B site so that the net cationic charge can be +2. This only shows that a variety of perovskites can be generated by suitable substitution at both A and B sites and hence a variety perovskite materials can be generated.

In addition to size and charge, there are also the bonding/coordination preferences for the metal ions involved. The dimensionality from 3D to lower order (2D or less) the restrictions imposed by the value of tolerance factor is relaxed and For example, in two-dimensional (2-D) layered derivatives of the perovskite structure, there are no known restrictions for the interlayer “A” cation length and, in the 0-D derivatives, size restrictions are not applicable altogether, as MX_6 octahedra are isolated and can readily shift in relative position. This structural flexibility and tunability of the dimensionality provide a rich and fertile “playground” for the preparation of interesting crystal structures with varying physical properties and also structural variations. Even though, it is considered that size restrictions may be relaxed for the lower dimensional perovskites, there are still other important parameters to be considered for the successful design and synthesis of a desired perovskite-related structure. The organic cation “A” must contain terminal functional groups that can ionically interact with the anionic inorganic substructure, but without the rest of the organic molecule interfering with the inorganic components “B” and “X”. Most of the known layered perovskite derivatives feature mono- or diammonium cations, yielding the general formulas of $(\text{RNH}_3)_2\text{BX}_4$, where “R” represents an organic functional group. The presence of ammonium cations leads to various hydrogen bonding schemes with the anionic substructure, which are important for determining the orientation and conformation of the

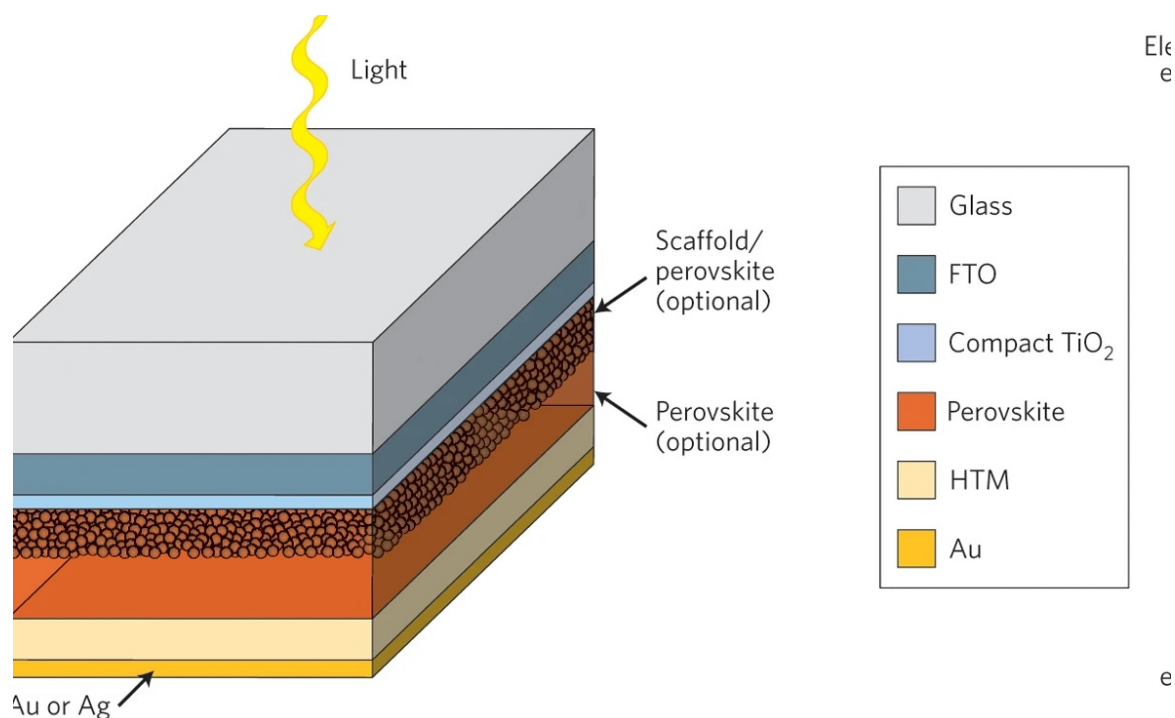

Figure 6.5: A diagrammatic design of solar cell

interlayer organic cations. Depending on the choice of metal, the inorganic framework can be more or less rigid, which also influences the hydrogen bonding schemes.

In general, both the organic cations and the anionic inorganic framework have templating influence on each other on the basis of size, width and length, allowing a certain degree of control over the final structures adopted and the resultant properties.

6.4 Opto-Electronic Property

Even though, initially it was considered that the organic moiety in HOIPs is only fulfilling the space filling function, the organic moiety now is known to alter the HOMO-LUMO energy levels and thereby enabling an active role in the opto-electronic properties of the solid.

The Perovskite Solar cells (PSCs') quick increase in PCE from 3.8% to nearly 25.2% within a decade (as shown in the previous sections) indicates their potential for exploitation. The approach to efficiency increase included changes to the device architecture, (various architectures like Mesoporous perovskite solar cell, Regular planar perovskite solar cell, Inverted planar perovskite solar cell, and so on), new carrier transport materials (ETLs and HTLs), and improvements to the absorber layer. The alteration of the anionic and cationic components, such as the use of FA along with MA and mixed halides, improves the absorber layer. The structural and opto-electronic characteristics of the film depend on the added solvent, the method used to make the film, the annealing temperature, and environmental factors like temperature, moisture content, oxygen, and others in addition to the organic and inorganic components in the perovskite layer. To design an effective PSC, it is necessary to have a control over the stoichiometry, grain structure, and crystallographic phase of the perovskite layer.

Table 6.1: Typical values of ionic radii for some cations and anions commonly found in perovskite lattices. The two values given for some cations refer to those reported by Kieslich et al. [4] and Becker et al. [19].

Anion	Effective radius $r_{X,\text{eff}}$ (pm)
Fluoride	129
Chloride	181
Bromide	196
Iodide I^-	220
Formate HCOO^-	136
Oxide O^{2-}	146
Sulfide S^{2-}	184
Selenide Se^{2-}	192
Cyanide $(\text{CN})^-$...
Nitride (N_3)	140 (approx.)
Borohydride (BH_4^-)	...

6.5 Factors Influencing the Performance of Perovskite Materials

Let us consider briefly the various factors that influence the performance of perovskite materials.

6.5.1 Solar Radiation

It is known that seasonal variations can cause the extent of solar energy in the range 1.4 kW/m^2 to 1.31 kW/m^2 . at the earth means distance from the sun. The wavelength range of 250 nm - 3000 nm accounts for more than 80% of solar electricity. Photons with a wavelength approaching 600 nm have the highest intensity in this solar spectrum. In addition, the effect of turbidity, ground reaction, and scattering are not negligible but they are not considered usually. A certain solar spectrum undergoing specific conditions is leveled with an air mass (**AM**) standard symbol. Some of the scales normally used to denote the solar ration are defied as follows: **AM0** denotes the sun spectrum outside of the atmosphere. At that point, the actual path length of solar radiation is assumed to be zero. **AM1**: The equator and its environs receive sun radiation with a zenith angle of 00, resulting in an AM coefficient of 1. **AM1.5** It is the conventional solar spectrum, with $\theta = 48.20^\circ$, that's used in solar cell testing on the ground. The majority of the world's population lives in a moderate climate zone between the tropics and the arctic.

6.5.2 Influence of Thickness

One of the important approaches for The MAPbI_3 based PSC device is accomplished using this parameter. It is known that the short circuit current increases as the material exposed to light increases and thus gives rise higher excitons generation. But still higher thickness, a recombination effect comes to play in the PSC device. .

6.5.3 Influence of Defect Density

Another parameter that influences the overall outputs of the perovskite devices is the defect density.. The bulk defect density significantly impacts the performance of perovskite solar cells. Incomplete dangling bonds within the material leads to additional trap energy levels

Table 6.2: Typical values of effective ionic radii for some cations commonly found in perovskite lattices. The two values given for some cations refer to those reported by Kieslich et al. [4] and Becker et al. [19].

Cation	Effective radius $r_{A,\text{eff}}$ (pm)
Ammonium $[\text{NH}_4]^+$	146, 170
Hydroxylammonium $[\text{H}_3\text{NOH}]^+$	216, 226
Methylammonium $[\text{CH}_3\text{NH}_3]^+$	217, 238
Hydrazinium $[\text{H}_3\text{N-NH}_2]^+$	217
Azetidinium $[(\text{CH}_2)_3\text{NH}_2]^+$	250, 284
Formamidinium $[\text{NH}_2(\text{CH})\text{NH}_2]^+$	253, 277
Imidazolium $[\text{C}_3\text{N}_2\text{H}_5]^+$	258, 303
Dimethylammonium $[(\text{CH}_3)_2\text{NH}_2]^+$	272, 296
3-Pyrrolinium $[\text{NC}_4\text{H}_8]^+$	272
Thiazolium $[\text{C}_3\text{H}_4\text{NS}]^+$	320
Ethylammonium $[\text{C}_2\text{H}_5\text{NH}_3]^+$	274
Guanidinium $[\text{C}(\text{NH}_2)_3]^+$	278, 280
Tetramethylammonium $[(\text{CH}_3)_4\text{N}]^+$	292, 301
Piperazinium $[\text{C}_4\text{H}_{12}\text{N}_2]^{2+}$	322
Tropylium $[\text{C}_7\text{H}_7]^+$	333
Dabconium $[\text{C}_6\text{H}_{14}\text{N}_2]^{2+}$	339
$[\text{C}_7\text{H}_7]^+$...
$[(\text{CH}_2)_4\text{NH}_2]^+$...
$[(\text{HN})(\text{CH}_2)_3\text{S}]$...
$[(\text{CH}_3)(\text{NH}_3)]^+$	317, 238

within the band gap and these levels acts as a recombination centre and reduces the carrier lifetime. These defects levels can be passivated by using compositional, chemical, or material engineering to reduce the defect density and increase the carrier lifetime for better performance. The defect density is known to affect both the short circuit current and also open circuit voltage.

6.5.4 Influence of Temperature

Thermal instability is a concern for researchers and scientists in Perovskite Solar cells (PSCs). The fact that annealing is a critical stage in the fabrication of perovskite films indicates that perovskites will likely be exposed to high temperatures. The operating temperature for solar cells ranges from 300 K to 400 K; hence, the newly fabricated perovskite solar cells must be able to tolerate high temperature conditions. Research has shown that the MAPbI_3 active layer has a very low thermal conductivity and also degrades at a temperature of 85 °C even in an inert atmosphere. On the contrary, the constituent material in the perovskite structure, in the ABX_3 type of structure, where A is a cation and primarily an organic cation component, is a volatile substance in nature that tends to degrade at high temperatures.

6.5.5 Influence of Moisture Content and Oxygen

The problem PSCs encounter is the perovskite layer's interaction with oxygen and water molecules. This is an inevitable occurrence that happens even when cells are being tested and put together. When water molecules react with the ABX_3 layer, the layer separates into its component parts. Taking MAPbI_3 layer as a standard example, the breakdown route is

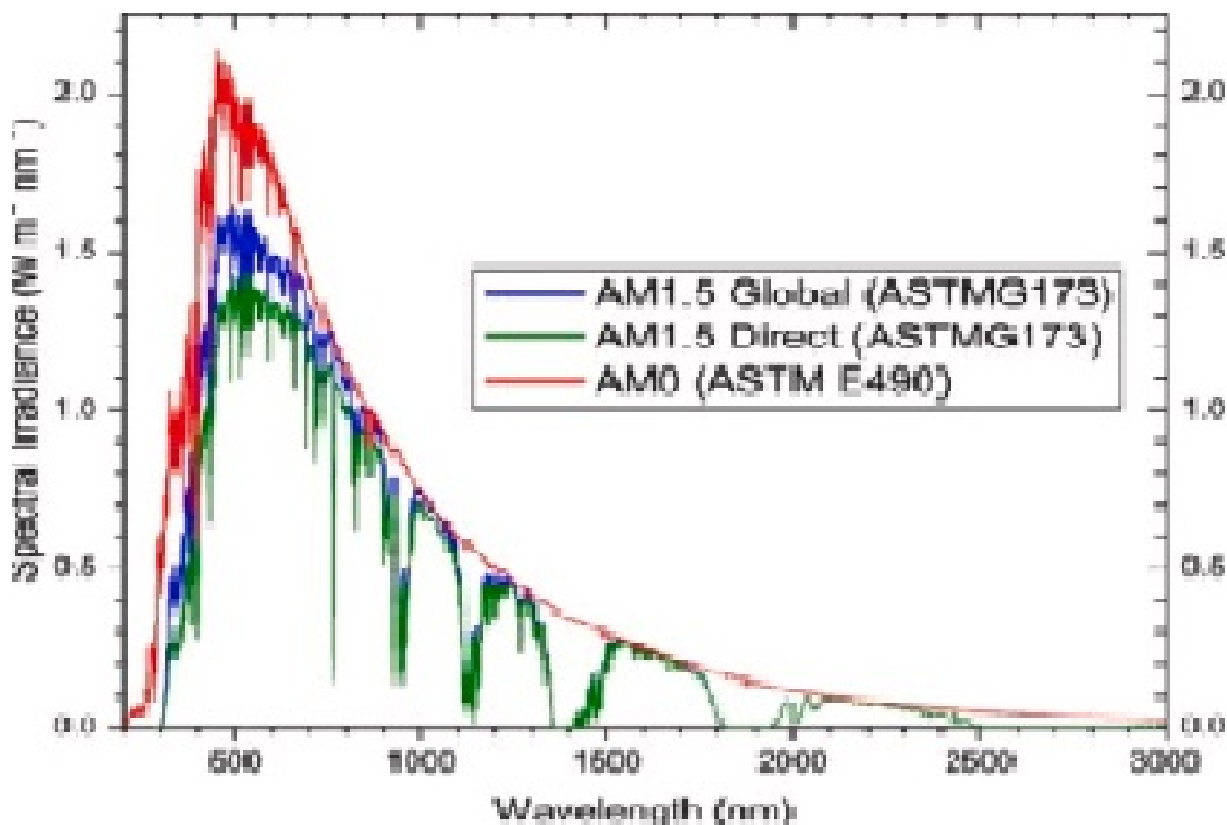

Figure 6.6: Comparison between the AM0, AM1, and AM1.5 solar spectrum.

explored. It first degrades into the original MAI and PbI_2 , then creates aqueous HI, solid PbI_2 , and volatile CH_3NH_2 as a result. The hygroscopic nature of the amine salts generally causes the instability caused by moisture. In the presence of moisture, the behavior of $\text{MAPbI}_{3-x}\text{Cl}_x$ and MAPbI_3 is similar: MA sublimates, leaving just PbI_2 remaining. The substance is hydrophilic, which causes it to rapidly absorb water from its environment and result in the fabrication of compounds that resemble hydrates (CH_3NH_3) $_4\text{PbI}_6 \cdot 2\text{H}_2\text{O}$)

6.5.6 Influence of Other Effects

Due to the ionic conductivity and low Frenkel and Schottky defect generation energies, the behavior of PSCs under electrical bias is a cause for concern. According to several theoretical research, the vacancy enhanced FA^+ , MA^+ , and ion movement. The ions low activation energies, which range from 0.1 to 0.8 eV, are equivalent to the energies of the ions in conductors. These ions can readily aggregate and migrate at the perovskite/contact interface under biased conditions, which lowers the internal potential and charge collection efficiency. The hybrid organic-inorganic perovskites have ionic characteristics and low ion migration activation energy.

6.6 The Challenges

The performance of the device, cost, and stability are the three determining elements for a solar cell's commercial viability. At this time, maintaining long-term stability at the module level and ensuring reliable outdoor operation are the biggest difficulties facing PSCs. There must be standards for the stability measuring methodologies. one has to have a stadard method to accurately anticipate the lifespan of PSCs under operating settings. The performance decay brought on by illumination and heat should be addressed.

The lifespan and efficiency of solar panels significantly impact cost per kilowatt-hour. The availability of abundance and cheap raw materials of PSC processing leads to cutting manufacturing costs below those of traditional PV systems. Indeed, PSCs become commercially competitive due to the lower production cost, which can eventually decrease the cost of the whole module.

A simple comparison of different solar cells are given in Table.

Table Comparison of Solar cell designs

Solar cell type	Merits	Demerits
Wafer-based solar cell	Tested Technology Easy fabrication process Reliable Inexpensive Plentiful and nontoxic High-conversion efficiency	Absorption coefficient is low Remand often exceeds supply Efficiency decreases when T increases temperature increases
Thin film-based solar cells	Easy fabrication for high volume More efficient when temperature is very high Flexible and lightweight	The power conversion efficiency is low Toxic materials are used Higher cost Stability is very low Lifetime is short

Perovskite solar cells have thus emerged as one of the most standout cell in terms of efficiency. Therefore the researchers have shown tremendous interest in Perovskite solar cells. Flexibility, lightweight, and semi-transparency are some of the valuable proportion of perovskite.

Bibliography

- [1] N. Suresh Kumar a, K. Chandra Babu Naidu, A review on perovskite solar cells (PSCs), materials and applications, *Journal of Materiomics* textbf7, (2021), 940-956.
- [2] Rabia Sharif, Arshi Khalid, Syed Waqas Ahmad, Abdul Rehman, Haji Ghulam Qutab, Hafiz Husnain Akhtar, Khalid Mahmood, Shabana Afzal and Faisal Saleem, A comprehensive review of the current progresses and material advances in perovskite solar cells, *Nanoscale Adv.*, (2023), **5**,3803.
- [3] B.Viswanathan, V. Suryakumar, B. Venugopal, SH Rosjima amd N.Hariprasad, Perovskite Materials an Introduction, e-book from National Centre for Catalysis Research, IIT, Madras (2019).
- [4] Kieslich, G.; Sun, S.; Cheetham, A. K. An Extended Tolerance Factor Approach for Organic-Inorganic Perovskites *Chem. Sci.* (2015), **6**, 3430– 3433 DOI: 10.1039/C5SC00961H; G. Kieslich , S. Sun and A. K. Cheetham , *Chem. Sci.*, 2014, **5** , 4712 —4715.
- [5] Jeon NJ, Noh JH, Kim YC, Yang WS, Ryu S, Seok SI.Solvent engineering for high-performance inorganic–organic hybrid perovskite solar cells, *Nat Mater* (2014);**13**:897.
- [6] Liu D, Kelly TL.Perovskite solar cells with a planar heterojunction structure prepared using room-temperature solution processing techniques, *Nat Photonics*, (2013),**8**,133.
- [7] Hong F, Saparov B, Meng W, Xiao Z, Mitzi DB, Yan Y.Viability of Lead-Free Perovskites with Mixed Chalcogen and Halogen Anions for Photovoltaic Applications, *J Phys Chem C* (2016),**120**6435.
- [8] Saparov B, Sun J-P, Meng W, Xiao Z, Duan H-S, Gunawan O, Shin D, Hill IG, Yan Y, Mitzi, Thin-Film Deposition and Characterization of a Sn-Deficient Perovskite Derivative Cs_2SnI_6 , *Chem Mater* (2016)**28**,2315.
- [9] Xiao Z, Meng W, Wang J, Mitzi DB, Yan Y.Searching for promising new perovskite-based photovoltaic absorbers: the importance of electronic dimensionality, *Mater Horiz*, (2017) **4**,206.
- [10] Xiao, Z.; Meng, W.; Saparov, B.; Duan, H.-S.; Wang, C.; Feng,C.; Liao, W.; Ke, W.; Zhao, D.; Wang, J.; Mitzi, D. B.; Yan, Y.Photovoltaic Properties of Two-Dimensional $(\text{CH}_3 \text{NH}_3)_2 \text{Pb}(\text{SCN})_3 \text{I}_2$ Perovskite: A Combined Experimental and Density Functional Theory Study., *J. Phys. Chem. Lett.* (2016),**7**, 1213-1218.
- [11] Yu Y, Wang C, Grice CR, Shrestha N, Zhao D, Liao W, Guan L, Awni RA,Meng W, Cimaroli AJ, Zhu K, Ellingson RJ, Yan Y. Synergistic Effects of Lead Thiocyanate Additive and Solvent Annealing on the Performance of Wide-Bandgap Perovskite Solar Cells *ACS Energy Lett* (2017);**2**,1177.

- [12] Liao W, Zhao D, Yu Y, Grice CR, Wang C, Cimaroli AJ, Schulz P, Meng W, Zhu K, Xiong RG, Yan Y. Lead-Free Inverted Planar Formamidinium Tin Triiodide Perovskite Solar Cells Achieving Power Conversion Efficiencies up to 6.22%, *Adv Mater*, (2016), **28**,9333.
- [13] Mitzi, D. B. Synthesis, Structure and Properties of Organic-Inorganic Perovskites and Related Materials Prog. Inorg. Chem. 1999, 48, 1– 121 DOI: 10.1002/9780470166499.
- [14] Mitzi, D. B. Templating and Structural Engineering in Organic-Inorganic Perovskites J. Chem. Soc., Dalton Trans. 2001, 1– 12 DOI: 10.1039/b007070j
- [15] Goldschmidt, V. M. Die Gesetze der Krystallochemie Naturwissenschaften 1926, 14, 477–485 DOI: 10.1007/BF01507527.
- [16] Rabia Sharif, Arshi Khalid, Syed Waqas Ahmad, Abdul Rehman, Haji Ghulam Qutab, Hafiz Husnain Akhtar, Khalid Mahmood, Shabana Afzal and Faisal Saleem. A comprehensive review of the current progresses and material advances in perovskite solar cells, *Nanoscale Adv.*, (2023), **5**,3803.
- [17] Bayrammurad Saparov and David B. Mitzi, Organic–Inorganic Perovskites: Structural Versatility for Functional Materials Design, *Chem. Rev.*, (2016),**116**, 7, 4558–4596.
- [18] M. A. Green, A. Ho-Baillie and H. J. Snaith, The emergence of perovskite solar cells, *Nat. Photonics*, (2014), **8**(7), 506–514.
- [19] M. Becker , T. Klüner and M. Wark ,Formation of hybrid ABX₃ perovskite compounds for solar cell application: first-principles calculations of effective ionic radii and determination of tolerance factors† *Dalton Trans.*, (2017), **46** , 3500.
- [20] Sagar Bhattarai, Asya Mhamdi, Ismail Hossain, Yassine Raoui, Rahul Pandey, Jaya Madan, Abdelaziz Bouazizi, Madhusudan Maiti, Dipankar Gogoi, Arvind Sharma, A detailed review of perovskite solar cells: Introduction, working principle, modelling, fabrication techniques, future challenges, *Micro and Nanostructures*, **172**(2022), 207450.
- [21] Sahil Kumar, Vishal Sharma, Neha Kumari Gun Anit Kaur¹, Anirban Saha· Sapna Thakur· Mamta Shandilya,Recent advances in perovskite materials: exploring multifaceted properties for energy harvesting applications, *Ionics*, <https://doi.org/10.1007/s11581-024-05658-3>
- [22] Sarat Kumar Sahoo, Balamurugan Manoharan and Narendiran Sivakumar, Chapter 1 - Introduction: Why Perovskite and Perovskite Solar Cells?, in *Perovskite Photovoltaics ,Basic to Advanced Concepts and Implementation*, 2018, Pages 1-24. <https://doi.org/10.1016/B978-0-12-812915-9.00001-0>.
- [23] Nisar Ali, Naeem Shehzad, Sarir Uddin, Rashid Ahmed, Musarrat Jabeen, Abul Kalam, Abdullah G. Al-Sehemi, Hussein Alrobei, Mohammed Benali Kanoun, Amir Khesro, Souraya Goumri-Said, A review on perovskite materials with solar cell prospective, *International Journal of Energy Research*, 06 August 2021 <https://doi.org/10.1002/er.706>.
- [24] Jiang-Yang Shao, Dongmei Li, Jiangjian Shi, Chuang Ma, Yousheng Wang, Xiaomin Liu, Xianyuan Jiang, Mengmeng Hao, Luozheng Zhang, Chang Liu, Yiting Jiang, Zhenhan Wang, Yu-Wu Zhong, Shengzhong Frank Liu, Yaohua Mai, Yongsheng Liu, Yixin Zhao, Zhijun Ning, Lianzhou Wang, Baomin Xu, Lei Meng, Zuqiang Bian, Ziyi Ge, Xiaowei Zhan, . . . Qingbo Meng, Recent progress in perovskite solar cells: material science, *Science China Chemistry*, **Volume 66**, pages 10–64, (2023)

Chapter 7

PROPERTIES OF PEROVSKITES

7.1 Introduction

Among all the materials, Perovskites find a unique place because they find application in a variety of fields among them, the chief ones are Piezoelectricity, pyro-electricity, Ferroelectricity, Superconductivity, their main applications in solar cells (this aspect has been already considered) solid oxide fuel cells, thin film capacitors and many more.

7.2 phase Transitions in Perovskites

The different phases and structural transitions exist when there is a change in temperature. Specifically, these transitions include a cubic phase occurring above 120 °C, followed by a tetragonal phase between 120 and 5 °C, an orthorhombic phase between 5 and -90 °C, and ultimately a rhombohedral phase below -90 °C. Notably, during the rhombohedral phase, the crystal's polar axis is aligned with a body diagonal. Below the Curie temperature, which defines the transition from ferroelectric (FE) to paraelectric (PE) phase, the crystal structure deforms into the tetragonal phase, resulting in spontaneous polarization and ferroelectric and piezoelectric behavior. BaTiO₃ exhibits distinct phases depending on temperature variations. It acquires a paraelectric cubic phase above its Curie point, approximately at 120 °C. In the temperature range from 130 to 0 °C, it stabilizes into a ferroelectric tetragonal phase with a c/a ratio of approximately 1.01. The spontaneous polarization in this phase aligns with one of the [001] directions from the original cubic structure. BaTiO₃ assumes a ferroelectric orthorhombic phase transition between 0 and -90 °C, with polarization along one of the [109] directions in its original cubic structure. When the temperature falls below -90 °C, an orthorhombic to ferroelectric rhombohedral phase transition occurs, with polarization following one of the [110] cubic orientations. This spontaneous polarization below the Curie temperature (T_C) results from changes in the crystal structure. Table 1 shows the substitution of various dopants and their influence on phase transition. The cubic phase displays paraelectric characteristics and has a very small dielectric constant, but the tetragonal phase indicates ferroelectric characteristics, which are more useful for dielectric applications due to its high dielectric constant.

Perovskite materials find utility across a diverse array of applications, including capacitors, non-volatile memories, actuators, sensors, piezoelectric devices, ultrasonic equipment, underwater technologies, high-temperature heating systems, frequency filters for wireless communications, and more. Perovskite materials can be nano-crystalline, bulk, thin films, or rods, depending on their application. Several factors make perovskite-type structures functional, such as non-stoichiometric arrangements of cations and anions, irregular cation configurations,

and an electronic structure with mixed valences. These structures support most periodic table metals. Multi-component perovskites (ABO_3) can be synthesized by partially substituting cations in the A and B locations. This technique creates complex, multifaceted materials in a perovskite-type oxide structure. These properties make perovskite materials distinctive. Ferroelectricity allows spontaneous electric polarization that may be reversed with an electric field.

7.3 Piezoelectricity

The Nobel laureates, Pierre and Jacques Curie first identified the piezoelectric behaviour in 1880 through measuring surface charges that appeared on various crystals when subjected to stress, the materials they studied include tourmaline, quartz, and Rochelle salt. An intense research and development into piezoelectric materials was started with the discovery of piezoelectric ceramics with remarkable behaviour, which led to their wide ranging applications. One of them, is barium titanate ($BaTiO_3$) ceramic, and it was found to have a dielectric constant of 1100. This value was ten times greater than the value for rutile TiO_2 .

Due to the discovery of additional piezoelectric ceramics, including lead niobate in 1952 and lead zirconate titanate (PZT) in 1955, the production of these materials picked up in the late 1950. Today, a number of piezoelectric ceramics, like $BaTiO_3$, PZT, lead magnesium niobate and lead zinc niobate are widely known. Non-centro-symmetric crystals show piezoelectricity behaviour, in which the application of stress causes the material to acquire an electric polarization. The development of an induced strain, on the other hand, is inversely proportional to an applied electric field. Piezoelectricity is a phenomenon exhibited by certain materials, showcasing their unique capability to produce an electric current in response to the application of mechanical force and, conversely, to convert electrical energy into mechanical motion. This fascinating property results from the interaction between mechanical stress and the electrical charge innate to these materials.

When these materials are subjected to mechanical stress, a transformation takes place. This transformation results in the separation of positive and negative ions within the material through the creation of electric polarization. There are essentially two groups of piezoelectric materials one group for which typical examples are quartz and tourmaline, where the atomic structures are ordered, and the second group examples like lead zirconate titanate, barium zirconate titanate and the piezoelectric property in these materials arise due to micro-structure and chemical composition. These materials find applications in a variety of disciplines, including sensors, transducers, actuators, and energy-harvesting devices.

Electric dipoles align parallel to the direction of the applied field in these materials when they are exposed to a high DC electric field, which polarizes the specimen. Electric dipoles are initially randomly oriented, but during application of field, they align in the applied field's direction to produce net polarization. Electric dipoles exhibit slight deviation from their symmetry after poling, which results in permanent polarization and mechanical deformation, resulting in the specimen's piezoelectricity. Additionally, the substitution or addition of dopants could improve the properties of piezoelectric materials by distorting the crystal structure and its properties. PZT is one of the piezoelectric materials that is most widely utilized and exploited for piezoelectric actuators, sensors, transducers, and so on, but it is extremely hazardous and can harm the kidneys, brain, nervous system, and particularly the intelligence of children. Moreover, the volatilization of PbO during the high-temperature sintering process results in instability in the production composition and electrical properties in addition to environmental degradation. A considerable amount of research has been done to find alternative piezoelectric materials in order to overcome the problem of lead toxicity. As a result, during the past two decades, research into new lead-free materials has greatly increased. Polarization in a material depends on two

primary factors: the magnitude of the applied stress and the nature of the stress, whether it is tensile or compressive. When an external pressure is applied to the material, it produces an electric charge proportional to the magnitude of the applied burden. This means that when a mechanical load is applied, the material will produce an electric charge proportional to the applied load. In the compression effect, volume is decreased, and it shows a voltage of the same polarity as the material, whereas in the case of the tension effect, volume is increased, and it shows a voltage opposite to the polarity of the material.

7.4 Pyroelectricity

The pyroelectric phenomenon was noticed in 400 BC in Greece due to the ability of heated tourmaline crystals to attract small objects. The pyroelectric effect was first studied in relation to its possible origin, particular material performances, and potential applications during the 1930s. Since the pyroelectric phenomenon is used in thermal detectors, it has been the subject of extensive research. The term “pyroelectric effect” describes a shift in spontaneous polarization that occurs in some polar materials as a result of temperature fluctuations known as an electrocaloric effect, which can alter temperature as a result of polarization variation, like the piezoelectric materials. One intriguing characteristic of some materials is their capacity to produce an electric potential in response to temperature changes, whether they are heating or cooling. When a material temperature fluctuates, positive and negative charges within the material migrate to opposing ends, causing this phenomenon. An electrical potential difference and material polarization are the outcomes of this movement. The pyroelectric effect mechanism is connected to spontaneous polarization. The electric dipoles only vibrate at random in the vicinity of their aligning axes at a constant temperature, which leads to a constant total spontaneous polarization. As the temperature rises, the electric dipoles oscillate at a greater angle, which reduces both the number of bound charges and the overall spontaneous polarization. In order to offset the bound charges, the free charges correspondingly redistribute, creating an electron flow, or pyroelectric current. Paradoxically, a pyroelectric current will be produced in the opposite direction if the material is cooled instead of heated. The pyroelectric coefficient, in the absence of an external electric field, can be treated in terms of the pyroelectric current and the change in temperature. Pyroelectric current can be measured to determine the pyroelectric coefficient. In pyroelectric applications, pyroelectric ceramics are fairly significant. They have many benefits, such as good mechanical qualities, low cost, easy manufacturing in large areas, and dependable electrical performance. The common understanding of perovskite materials’ ferroelectricity is that a permanent electric dipole is created when a B-site ion is displaced from its centrosymmetric position in the unit cell along the *c*-axis. Thus, one can greatly alter the electrical properties by suitably altering the A or B site’s composition. In pyroelectric applications, there are numerous significant lead-free ceramic systems, including ceramics based on BaTiO_3 . Therefore, ferroelectric material (such as BaTiO_3) is non-centrosymmetric, piezoelectric, and pyroelectric. In the domain of ferroelectric crystals, these are the crystals that are inherently polar, and the direction of their spontaneous polarization can be altered by the application of an external electric field. Therefore, all ferroelectric materials are pyroelectric by nature. It is essential to observe, however, that not all pyroelectric materials possess this switchable polarization; this is the distinguishing characteristic that separates ferroelectric materials from other pyroelectric materials.

7.5 Ferroelectricity

In 1912, Erwin Schrodinger coined the term “ferroelectricity”. Spontaneous polarization in crystalline materials below a specific temperature known as the Curie temperature (T_c) is a phenomenon known as ferroelectricity. Under the influence of an external electric field, the polarization can reverse itself. Ferroelectricity is a spontaneous polarization of the specimen that is electrically switchable. The substances that exhibit this kind of behavior are known as ferroelectric substances or ferroelectrics. Piezo- and pyroelectric properties are shared by all ferroelectric materials. Polarization– electric field loop or ferroelectric hysteresis loop are terms used to describe how electric polarization lags behind an field is applied, the crystal domains have a natural tendency to align in the direction of the field. This results in the manifestation of various phenomena related to the hysteresis loop, including domain rotation and domain growth. Electric dipoles begin to align themselves towards the electric field when it is applied, which results in net polarization in the specimen. At higher electric fields, every single dipole is pointed directly in the direction of the field, causing saturation in the polarization, also known as saturation polarization. Polarization changes its direction in response to an electric field reversal. Remnant polarization, a specific value of polarization, exists when the electric field is zero or when there is no electric field. The coercive field is the name given to the field that is applied in the opposite direction to cause remnant polarization to be zero. The thickness of the specimen, the locations of flaws, mechanical stress, and thermal treatment are only a few of the variables that might affect the P-E loop. The transition from ferroelectric to paraelectric above T_c reveals the lack of the P-E hysteresis loop. The synthesis and characterization of lead-free materials with properties comparable to those of materials based on $\text{Pb}(\text{Zr},\text{Ti})\text{O}_3$ (PZT) are receiving a lot of attention in the field of ferroelectrics. When the randomly distributed ferroelectric domains in ferroelectric ceramics are aligned through the poling process, piezoelectricity is produced. During World War II, there was another research that led to the finding of ferroelectricity in barium titanate and other perovskite-based materials. Since then, these materials have been utilized in a wide variety of applications, including the creation of ferroelectric capacitors for electronic devices and non-volatile memory, piezoelectric sensors, actuators, and even medical ultrasonic imaging. With the help of the tolerance factor (t), we can describe the ferroelectric behavior of perovskites. Antiferroelectrics have a distribution of 0.78 less than or equal to t less than or equal to 1.0, while ferroelectrics cover the whole perovskite range of 0.78 less than or equal to t less than or equal to 1.05. In complex and simple perovskites, phase compounds with low t and x tended to form pyrochlore phase(s). However, raising t in solid solutions stabilizes perovskites. Ferroelectrics have a dielectric constant that is two orders of magnitude higher than that of regular dielectrics. BaTiO_3 , a ferroelectric material with a relative dielectric constant exceeding 2000 and a permanent electric dipole, is an example of this. However, polarization in the solid is caused by the alignment of neighboring unit cell dipoles. The existence of spontaneous polarization promotes numerous energy applications like nanogenerators, sensors, and multi-layer capacitors.

7.6 Superconductivity

Superconductivity, a phenomenon, has found intriguing expression in perovskite materials. In recent years, these materials have been receiving attention due to their extraordinary electrical and optical properties, which make them valuable for a variety of applications, ranging from photovoltaics to superconductivity. A superconductor is a material that exhibits zero electrical resistance and expulsion of the magnetic flux when a material is cooled below some temperature (critical temperature). It was first discovered in 1911 by Dutch physicist Heike Kamerlingh

Onnes in mercury when he cooled it to 4 °K. Following the discovery of superconductivity in perovskite and related cuprate systems in 1986, interest in the perovskite structure increased. The majority of cuprate superconductors crystallize in the perovskite structure. In fact, because of its intriguing features, perovskite structure compounds are among the most investigated types of compounds currently. Two significant non-cuprate $\text{Ba}_{1-x}\text{K}_x\text{BiO}_3$ ($T_c\text{-max} = 30$ K), are derived from BaBiO_3 with the perovskite structure. The structural foundation for supporting charge density waves (CDWs) in BaBiO_3 and a combination of Bi^{3+} and Bi^{5+} is provided by this crystal structure. The phenomenon of superconductivity can be explained by the BCS theory, which is based on the Cooper pair. A Cooper pair is an electron–electron pair that is formed at low temperatures. Numerous practical applications have resulted from these properties, including highly efficient electrical transmission lines, powerful electromagnets used in magnetic resonance imaging (MRI) devices, and particle accelerators. At the starting stage, the critical temperature is low for the superconductor materials. Mixed valence oxides have a low tendency of states per unit cell $N(EF)$ at the Fermi level and should have a tendency of large electron–phonon coupling constant. The phase diagram of coupling constant $\lambda = [N(EF)]V^*$ versus T proposed by Chakraverty has three phases: metallic, insulating bipolaronic, and superconductor. Metallic phase has a small value of λ , insulating bipolaronic phase has a large λ , and superconductors have λ between both. The Jahn–Teller polaron model is the primary source of knowledge regarding the increase in critical temperature. This model proposes that a nonlinear molecule or molecular complex that exhibits electronic degeneracy will inherently endure distortion in order to eradicate or mitigate this degeneracy. In cases of minor JT disorder in which the stabilization energy (EJT) remains less than the metal’s bandwidth, an increase in EJT corresponds to a greater propensity for localization. These electron and lattice distortion combinations, characterized by a substantial effective mass, are capable of traversing the lattice as a single unit. As a result, a strong electron–phonon coupling becomes evident. Hence, cuprates are introduced in making superconductors, which are helpful in raising the critical temperature. The cuprate superconductor adopts the structure of perovskites, in which electron moves within weakly coupled copper oxide with $\text{Ba}_{1-x}\text{K}_x\text{BiO}_3$ ($T_c\text{-max} = 30$ K), are derived from BaBiO_3 with the perovskite structure. The structural foundation for supporting charge density waves (CDWs) in BaBiO_3 and a combination of Bi^{3+} and Bi^{5+} is provided by this crystal structure. The cuprate superconductor adopts the structure of perovskites, in which electron moves within weakly coupled copper $\text{Ba}_{1-x}\text{K}_x\text{BiO}_3$ ($T_c\text{-max} = 30$ K), are derived from BaBiO_3 with the perovskite structure.

7.7 Multiferroicity

“Materials should exist, which can be polarized by a magnetic field and magnetized via an electric field.” P. Curie. A remarkable class of materials displaying simultaneous ferromagnetic, ferroelectric, and ferroelastic ordering is represented by multiferroics. H. Schmid coined the term “multiferroic” in 1994. Multiferroic materials with the corresponding properties are shown in Figure.7.1. . These materials are unique in that they have the capacity to simultaneously use both their magnetization and polarization states, a huge potential that would make them excellent candidates for next-generation sensors and memory technology. Numerous multiferroics, such as rare-earth manganites and ferrites, are transition metal oxides with perovskite crystal structure (e.g. HoMn_2O_5 , TbMnO_3 , LuFe_2O_4). Systems like $\text{Ba}_2\text{CoGe}_2\text{O}_7$, $\text{Ca}_2\text{CoSi}_2\text{O}_7$, $\text{TbFe}_3(\text{BO}_3)_4$, CoCr_2O_4 , FeCr_2O_4 , MnCr_2O_4 , $\text{NdFe}_3(\text{BO}_3)_4$ are those substances that exhibit multiferroicity even at ambient temperature. Bismuth ferrite (BiFeO_3), a rhombohedrally distorted perovskite, is one of the many multiferroics that have been studied, and it is receiving attention because it exhibits both ferroelectric order and anti-ferromagnetic order over a wide

temperature range that is significantly above room temperature. The majority of ferromagnetic materials are typically metals, therefore a ferroelectric material must be an insulator. As a result, the simultaneous occurrence of ferroelectric and ferromagnetic ordering is constrained by the lack of ferromagnetic insulators. Multiferroics are still uncommon even when antiferromagnetic systems are taken into account. A structural deformation from the high symmetry phase, which removes the centre of inversion and enables an electric polarization is the traditional prerequisite for ferroelectricity. Ferroelectricity and ferromagnetism exhibit synchronous time. Unpaired d electrons are necessary for any type of magnetic ordering, however ferroelectric materials like typical perovskite oxides lack this property (ABO_3) have a d^0 configuration on the small B cation. The tendency for the tiny cation to generate a distortion that removes the centre of symmetry is significantly suppressed if the d shell is only partially populated. With some unpaired electrons in the d orbitals, magnetoelectric multiferroic materials should exhibit some deformation in their crystal structure. Recently, it was discovered that magnetic spin ordering can create ferroelectricity even in the absence of any structural distortion. As a result, there are now a lot more ferroic materials that could be used. Experimental and theoretical research both point to a new era in the attainability of multiferroicity in transition metals doped $BaTiO_3$. Extrinsic and intrinsic dopants like excess oxygen vacancies and transition metal cations can be added to these materials to improve their chemical and physical properties. The electrical or magnetic characteristics of perovskites with transition metal ions (TM) doped on the B site are incredibly diverse and intriguing. This variety is more closely linked to the intricate role that transition metal ions play in certain coordinations with oxygen or halides than it is to the chemical flexibility of these compounds. Although unfilled 3d electron shells of the TM are typically associated with magnetism and electronic correlations, filled 3d electron shells are associated with dielectric characteristics. Due to the limited number of low-symmetry magnetic point groups that permit spontaneous polarization, multiferroicity, the coexistence of spontaneous ferroelectric and ferromagnetic moments, is a rare phenomenon. One of two categories can be used to group all multiferroic materials. Multiferroics of type I and type II. At high temperatures, Type I go through a structural, nonpolar-to-polar phase transition that, in most cases, involves the breaking of inversion symmetry and results in ferroelectricity. At lower temperatures, the emergence of magnetic order takes place below a different phase transition. The prerequisites for ferromagnetism and ferroelectricity (polarization) (unpaired electron spin motion) parameter for type II is the staggered antiferromagnetic) magnetization. Below a certain temperature, magnetic ordering transforms the symmetry group from a non-polar parent phase to a polar magnetic phase. This results in inappropriate ferroelectricity. Additionally, magneto-structural coupling to the crystal structure creates an electrically polar state. However, polar non-centrosymmetric magnetic structures typically originate from the complicated magnetic ordering of geometrically frustrated states or from competing interactions in this situation, where the magnetic and ferroelectric order parameters are intimately related.

7.8 Colossal magnetoresistance (CMR)

Some materials have a feature called colossal magnetoresistance (CMR) that allows them to drastically alter their electrical resistance when a magnetic field is present (mostly manganese-based perovskite oxides). CMR was first identified in mixed valence perovskite manganites in the 1950s by G. H. Jonker and J. H. van Santen. These materials have generated a great deal of interest. Different magnetic phases, including insulating antiferromagnetic phases with multiple orbital orders and a ferromagnetic, metallic, orbitally disordered phase, are detected depending on the orbital occupancy of the manganese ions and the related orbital order. Because of

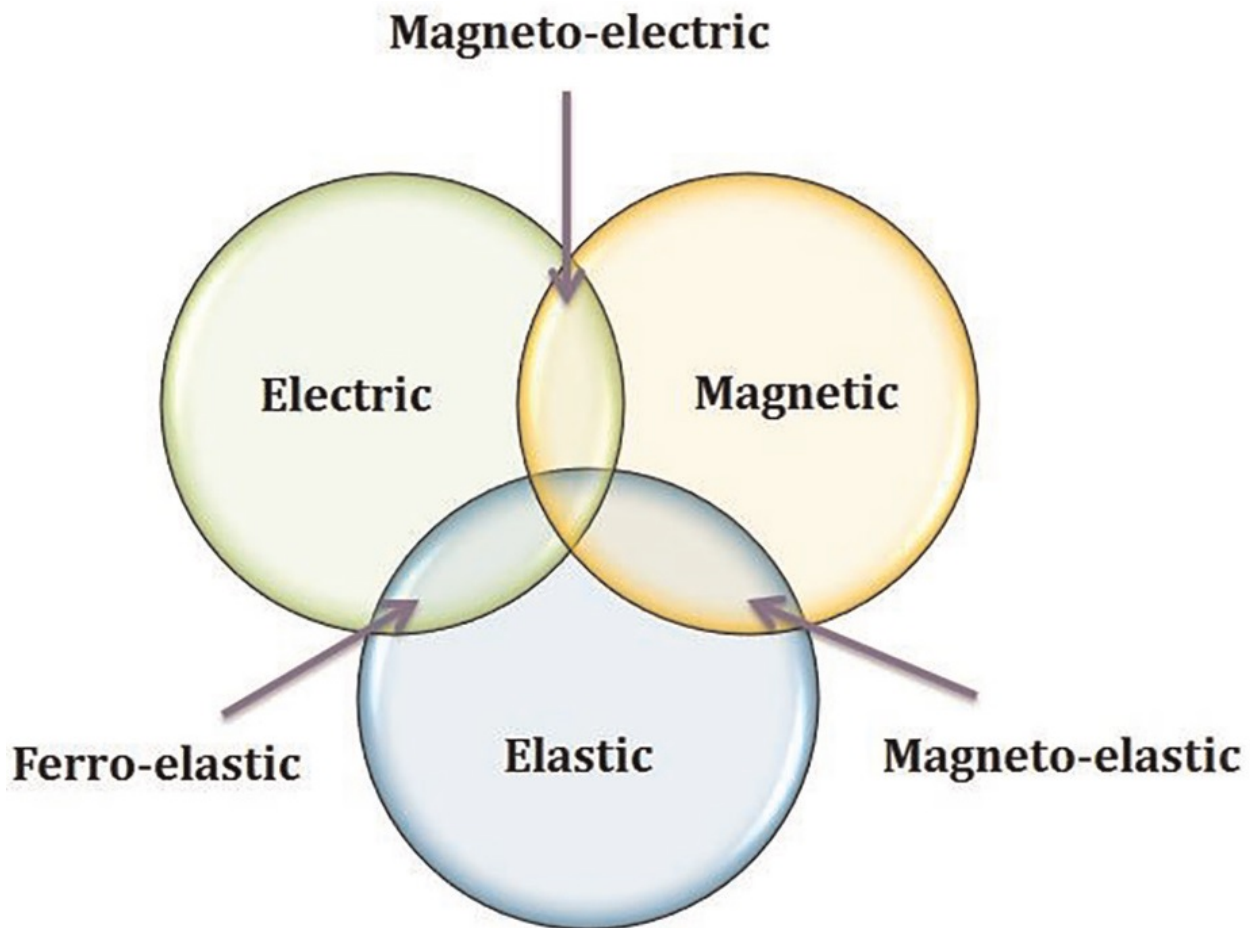

Figure 7.1: Multiferroic Materials

the close coupling between spins and orbitals in these compounds, both degrees of freedom have ordering temperatures that are similar in magnitude. In a three-dimensional lattice, the primary spin exchange pathways pass over almost 180 TM-O-TM limits (TM-transition metal). But merely taking into account spins, low dimensionality, magnetic frustration, and quantum processes can also result in some incredibly strange phase diagrams, even ones without magnetic long range order. In fact, in frustrated lattices, quantum fluctuations or a second order energy scale can frequently lift the degeneracy of the magnetic ground state. The nature of CMR manganites, which are strongly correlated electron systems with interactions between the lattice, spin, charge, and orbital degrees of freedom, including the double exchange interaction, Jahn-Teller effect, electronic phase separation, charge ordering, etc., is generally thought to be the root cause of the CMR effect.

7.9 Other Properties

other properties of perovskites that have been exploited include as electrode materials in Solid Oxide Fuel Cells (SOFC), thin film capacitors, Lasers and Light emitting diodes and some memory devices in addition to Solar cell application (this has been dealt with in a separate chapter). A fuel cell is an electrochemical device that produces electricity through a chemical reaction between a fuel and an oxidizing agent, typically oxygen or air. It operates on the same principles as a battery but differs in that it can generate electricity continuously as long as it is supplied with fuel. There are various types of fuel cells they can be classified on the basis of electrolyte employed in them like SOFC, MCFC, PEMFC, PAFC, DMFC AFC and so

on.(AFC).

SOFCS have been gaining attention in recent years. This increased interest in solid oxide fuel cells is due to the various advantages of SOFCs, among other forms of fuel cells. SOFCs are the technology with their optimal power generation features and maximum electrical efficiency for automobiles and household devices. SOFCs can run on a wide range of fuels, like hydrocarbons, natural gas, methane, propane, hydrogen and on a combination of biofuels. Perovskite materials are extensively utilized in SOFCs as the cathode, the anode, and the electrolyte. This is due to the fact that large varieties of dopants that have distinct and variable states are readily available and may be positioned at the A and B sites of the perovskite lattice. The basic structure of a solid oxide fuel cell typically consists of several key components: electrolyte, anode, cathode, bipolar plates, and current collectors. The cathode is the electrode on the oxidant (usually air or oxygen) side of the SOFCs. Perovskite minerals are frequently used in their production; examples include lanthanum strontium manganite (LSM) and lanthanum strontium cobalt ferrite (LSCF). By taking electrons and oxygen ions in order to generate oxide ions, the cathode makes the electrochemical reduction of oxygen easier to accomplish, and the anode is the electrode on the fuel side of the SOFC. Porous materials, such as ceramics based on nickel or cermet (ceramic-metal composites), are usually utilized in their construction. The anode acts as a catalyst for the electrochemical oxidation of the fuel, which is hydrogen, into protons and electrons. The electrolyte in the solid oxide fuel cell is an essential component because it serves to partition the fuel and oxidant gases. It is clear that perovskite materials find wide application in energy conversion devices.

7.10 Thin Film Capacitors

Perovskite thin films have high dielectric values, which makes them ideally suitable for capacitor applications. Capacitors are generally used for signal coupling, signal decoupling, filtering, and impedance matching. Single-layer thin films have lower inductance than multi-layer ceramic capacitors because of the high mutual inductance between the internal counter electrodes, which can lead to a reduction in the size of electronic systems due to the integration of the capacitor and another component. The reduction of components improves the performance of the system. This aspect is critical for high-frequency circuitry. Thin films designed for employment within the microwave frequency spectrum are coveted due to their inherent attributes, including minimal attenuation at microwave frequencies, negligible intermodulation distortion, and cost-effectiveness in the production process. Moreover, thin-film devices have a distinct advantage over bulk materials because their structural configurations are perfectly compatible with planar microwave circuits. In general, the energy storage efficacy of thin film samples is significantly superior to that of their bulk counterparts. Thin films with fewer defects can attain higher breakdown strength, which is an advantage. Perovskites and their unique properties, such as high energy conversion efficiency and the ability to be processed as thin films, have garnered considerable attention.

7.11 Laser and Light-Emitting Diodes

Lasers and light-emitting diodes (LEDs) are light sources in modern technology, yet they differ significantly in terms of operation and application.

7.11.1 Laser (Light Amplification by Stimulated Emission of Radiation)

. Lasers operate using the stimulated emission principle. The characteristics of laser beam are that they are focused, coherent, and monochromatic, implying that the light waves are in phase, have a single color, and are focused on a narrow beam. There are a variety of applications, like cutting and welding in manufacturing, medical procedures, and optical communication.

7.11.2 Light-emitting diodes (LEDs).

LEDs are semiconductor devices that emit light when an electric current flows through them. LEDs emit incoherent light with a broader spectrum range than lasers. LEDs are extensively employed in numerous applications, including display screens, indicator lights, streetlights, and residential lighting. The commercialization of perovskite-based lasers and LEDs is an ongoing area of research, and challenges. Intense research is focused to realize the full potential of perovskite materials in laser and LED technology. Semiconductor solid-state lasers have seen significant advancements and have become elements in our everyday lives. A development in this field is the rise of halide perovskites, which has established them as viable competitors.

7.12 Memory Devices

There are a variety of memory devices that meet the need for non-volatile memory devices with faster switching speeds and greater endurance. Non-volatile memories are an important part of computer components. These materials can retain the information within the material itself when the power is interrupted. In developing non-volatile memories, there has been the use of ferroelectric thin films (ferroelectric random-access memories or Fe-RAMs). In Fe-RAMs, information is stored in the polarization state of the material. Early work was focused on PZT and SBT. In films, there must be a large difference between these two characteristics: remnant polarization (P_r) and reliable polarization cycling. One of the new storage devices for managing mass data is RRAM. Resistive random-access memory is promising because of its simple structure, fast switching, low power consumption, and high density. RRAM stores data through current-stage changes under electric fields. Active layers can be electrically charged from a low resistance state (LRS) to a high resistance state (HRS) by applying voltages at different amplitudes. RRAM has a sandwich-like structure of three layers, which consist of the top electrode, active layer, and bottom electrode. Many material systems exhibit resistive switching behaviors; organics, transition metal oxides, and perovskite oxides are a few examples. In addition to their hysteretic current–voltage (I - V) responses, analogue switching, flexibility, multilevel data storage, and the potential for low power consumption/ high-density memory applications are some of the benefits of using organic–inorganic hybrid perovskites (OIHPs). Consequently, they have been employed in the production of synaptic and resistive memory devices. For resistive switching memory and other next-generation memory devices, OIHP materials are attractive options for two reasons. Initially, both inorganic and organic counterparts can provide benefits for OIHP. Given that this material contains inorganic components, such as oxides and chalcogenides, it may exhibit superior resistive switching properties. But because of their brittleness, inorganic materials are not as useful for flexible electronics. As a result of the structural flexibility of organic parts, materials like A-site organic cations can find new uses in flexible devices. Secondly, optical memories could potentially use OIHP. Fast optical signal transfer is becoming a major concern in the field of optical communication in order to develop photon-writing memories. The light-harvesting and light-responsive qualities of this material have accelerated the development of photosensory devices, such as photodiodes and

phototransistors . A blend of perovskite/PS has been used to demonstrate OIHP-based photo memory with a heterojunction floating gate.

In essence, it can be stated that perovskite materials forms a family of materials with various structural, electric and optoelectronic properties. The possibility of substitution at both A and B sites with various cations (partial or total substitution) with ABO_3 symmetry offers a innumerable choices of materials from which one can choose and explore their properties for device application. properties. Some of these applications are considered in this presentation like thin film capacitor, piezo- and pyro-electricity and others.

7.13 References

[1] Sahil Kumar, Vishal Sharma, Neha Kumari, Gun Anit Kaur, Anirban Saha, Sapna Thakur, and Mamta Shandilya, Recent advances in perovskite materials: exploring multifaceted properties for energy harvesting applications, *Ionics* (2024). <https://doi.org/10.1007/s11581-024-05658-3>.

Chapter 8

Perovskite – A catalyst for Solar Hydrogen Production

8.1 Introduction

Essentially, the steps involved in the solar energy conversion, includes the solar light harvesting, charge separation and surface catalytic reaction, and an ideal material for solar hydrogen production should have several merits, such as a narrow band gap for visible light response, suitable position of the valence band top and conduction band edges so as to promote both hydrogen and oxygen evolution reactions, a long carrier diffusion length for efficient charge separation and an excellent surface reaction kinetics for rapid catalysis. Since perovskite photovoltaic devices has already reached an efficiency of 25.2 %, it is considered as one of the suitable materials for hydrogen production from water decomposition. The main reasons for this consideration are as follows:

- key1 The high light absorption coefficient empowers perovskites with the ability to harvest as much light as possible in the form of small particles or thin films
- key2 The precise tailoring of band gaps and band edges by varying the chemical compositions (i.e. easily replacing the cations in the crystal structure or forming extensive oxygen or halogen non-stoichiometry) makes the perovskite materials being thermo-dynamically favorable for solar hydrogen production
- key3 In Perovskites, the value of the band gaps can be modulated by band gap engineering, thus enabling more visible light from the sunlight can be utilized.
- key4 the long carrier diffusion length endowed by the unique property of perovskites facilitate more efficient charge separation in the bulk with a decreased recombination
- key5 In addition, the ferroelectric and/or piezoelectric properties of some perovskites has the potential to further enhance their activities by tuning the charge separation process
- key6 The cost to fabricate the peroskite-based devices by the solution-proceed methods is lower than that to obtain Si or Cu(In, Ga)Se₂ (CIGS) solar cells, which is a great advantage for the large-scale application of perovskites for solar hydrogen production.

Thus, it can be seen that using perovskite based materials will find wide application in hydrogen (fuel) production.

In view of these advantages, there is already number of studies are being carried out using perovskite materials for solar hydrogen production. . Different approaches have been

used to use the perovskites in the solar hydrogen production systems, including the particulate photo-catalysis (PC), photo-electrode-based photo-electro-catalysis (PEC), solar cell-based photovoltaic- electro-catalysis (PV-EC). Also, different perovskites, including the inorganic or organic-inorganic hybrid ones HOIP, are studied. Some of the systems have shown fairly good performances with the adequate modification of the perovskite material and the system configurations, sparking increasing attention in the further development of perovskites-based solar hydrogen production systems [2-5].

8.2 Principle of Water Decomposition

The reaction of water splitting to produce H_2 and O_2 molecules is an endothermic process requiring the extra energy input by sunlight to drive a reaction. A standard free energy change (G_0) of $237.2 \text{ kJ mol}^{-1}$ is required. However, there are some challenges like to repress the recombination of charge carriers in the bulk and at the catalyst/solution interface, and how to overcome the kinetic obstacles to activate and split the water molecule.

Usually, the water decomposition reaction is carried out in three configurations namely in particulate system (PC), or as photoelectrodes (photoelectrocatalytic system) and or in a photovoltaic mode.

In the PC system, the semiconductor nano-particles could provide enough degrees of freedom affecting the opto-electrical properties, such as the facet exposure, and particle size. The charge transfer pathway inside the particle for the PC system is shorter as compared to the other two water splitting systems. The semiconductor particles are directly placed into the electrolyte to construct a PC cell for solar hydrogen production. Under the sunlight illumination, the semiconductor will absorb the incident light with photon energy above the band gap ($h\nu$ greater than or equal to E_g), and the electrons from the valence band (VB) are then excited to the conduction band (CB), producing numerous energized electrons and holes in the CB and VB, respectively. After separation and transportation which are mostly driven by the semiconductor/electrolyte junction, the photo-excited carriers will reach the active sites at the surface of the photo-catalyst, and participate the subsequent water oxidation reaction and proton reduction reaction respectively. It should also be noted that some of the photo-excited carriers will recombine with each other inside the bulk and at the surface. To ensure that the photo-excited carriers have enough potential to drive the water splitting reactions, the bottom edge of the CB of the semiconductor should be more negative than 0 V, while the top edge of the VB should be more positive than 1.56 V (or thermodynamic decomposition potential). The hydrogen and oxygen are directly evolved over the surface of identical particles, and mix gaseous productions are then collected and treated with the gas-separation procedure to get the pure hydrogen.

In photoelectrochemical water decomposition, the cell is composed of a photocathode (p-type semiconductor) and/or a photoanode (n-type semiconductor), all of which are coupled in tandem with an external circuit to generate H_2 and O_2 on the photocathode and photoanode separately. Despite the driving force provided by the semiconductor/ electrolyte junction, external bias could also be added to the circuit to pump photogenerated electrons from the photoanode to the photocathode, contributing to the oriented charge carrier flow in the PEC cell. The Perovskite films could be directly prepared as the photoelectrode with/without modifications. As stated there are various modifications of the configuration of the cell are possible.

To estimate and compare the performances of different systems, the evolving rate of the H_2 product, the photocurrent density, and the solar-to- hydrogen (STH) efficiency of the entire process have been used to quantify the photo(electro)catalyst's ability for water splitting. The hydrogen evolving rate is used for the PC systems, while the photocurrent density is for the

PEC and PV-PEC systems. The STH efficiency is the most popular parameter for all solar hydrogen production cells.

Various strategies are adopted to modify the photocatalyst so as to facilitate the decomposition of water like band gap engineering, cocatalyst decoration, use of sacrificial agents like methanol or diethanolamine (for using holes or to facilitate the simultaneous oxidation reaction), conventional elemental doping, employing nanocomposites or using heterojunction devices. All these attempts have contributed to our understanding of the process.

Let us briefly list some of the improvements that can be made in using perovskites for harnessing solar energy in the photocatalytic mode. They can be idemized as follows:

- New materials based on semiconductor perovskites with improved photoactivity can be formulated that satisfies durability criterion, and also responding to red or near IR light. Compositing perovskites with ferroelectric materials or fabricating functional structures can also be a promising way. The instability of perovskites in aqueous solutions has to be addressed.
- The device fabrication method should include to increase the incident light absorption intensity. The devices have many layer configuration, it is essential that the overall resistance for charge transfer.
- Large-area hydrogen production process is needed for the industrial application. The most useful and practical application of perovskite-based large-scale H₂ evolution is the PV-EC solar hydrogen production system. In this regard, a perovskite solar cell with a high power conversion efficiency and a large V_{OC}, and efficient electro-catalysts for water oxidation and reduction reactions are desired.
- Since HOIPs are often employed, their stability especially in polar solvents must be ensured. New synthetic strategies have to be adopted.
- For the large-scale operation of perovskite devices for solar hydrogen production, the cost to fabricate the device is one important factor that needs to be considered.
- The toxicity of hybrid halide perovskites especially using lead as one of the components should be considered. New materials should have comparable power conversion efficiency have to be developed.
- Fundamental aspects of the perovskite-based device, such as the surface properties, charge carrier dynamics, and the catalytic reaction mechanisms, are complex conceptions with multiple processes or timescales. Understanding these fundamentals will be beneficial for the rational designing or construction of perovskite devices with high-performance.

8.3 References

- (1) Hui Bian, Deng Li, Junqing Yan, Shengzhong (Frank) Liu, Perovskite – A wonder catalyst for solar hydrogen production, *Journal of Energy Chemistry*, **Volume 57**, June 2021, Pages 325-340.
- (2) G. Zhang, G. Liu, L. Wang, J.T.S. Irvine, *Chem. Soc. Rev.*, 45 (2016), pp. 5951-5984.
- (3) L. Ma, W. Zhang, P. Zhao, J. Liang, Y. Hu, G. Zhu, R. Chen, Z. Tie, J. Liu, Z. Jin, *J. Mater. Chem. A.*, 6 (2018), pp. 20076-20082.
- (4) J. Chen, C. Dong, H. Idriss, O.F. Mohammed, O.M. Bakr, *Adv. Energy Mater.*, 10 (2020), p. 2070059.
- (5) S. Singh, H. Chen, S. Shahrokhi, L.P. Wang, C.-H. Lin, L. Hu, X. Guan, A. Tricoli, Z.J.

Xu, T. Wu, ACS Energy Lett., 5 (2020), pp. 1487-1497.

Chapter 9

Sensing Applications of Perovskites

9.1 Introduction

Perovskite materials hold promise in gas sensing applications, detecting specific gases with high sensitivity and opening up a wide range of potential applications in industrial process control and environmental monitoring. Although perovskite materials have gained attention due to their unique properties, their stability in the presence of moisture or oxygen remains a significant challenge. In this presentation the focus is on chemiresistive gas sensors based on perovskite oxides and fluorescence/photoelectrochemical sensors based on halide perovskites. It appears that perovskite materials have immense potential for driving the development of innovative sensor technologies. The need for sensors for human society is well recognized in these days due to various factors and the life style. The emergence of innovative sensing techniques, such as electro-chemical and optical sensors, holds promise for detection and quantification at such low levels (less than nanomolar). sensors normally operate based on changes in material properties. like resistance this is mainly employed for sensing gases) and optical sensors utilize changes in the color or wavelength of absorption or fluorescence intensity of materials in response to chemical compounds. In this section, we will concentrate on applications of oxide and halide perovskite materials for gas, ionic, and organic compound sensing based on their electric and optical properties. Specifically, the electric and optical characteristics of these materials respond to different analytes. We shall deal with two classes mainly with a focus on perovskite oxide-based chemi-resistive gas sensors and halide perovskite-based fluorescence/photoelectrochemical sensors.

9.2 Sensors Based on Perovskites

9.2.1 Chemiresistive Gas Sensors

The sensing principle of gas sensors is based on the difference in electrical properties between the sensing layer in the gas environment and the air. When the target gas interacts with the sensor layer, adsorption and electron transfer occur, resulting in changes in resistance and charge carrier concentration.

The essential and main components of a gas sensor include a substrate, a sensing layer, electrodes, and a heater. The substrate provides mechanical support disperses the active layer and electrical insulation, while the sensing layer is responsible for detecting the target gas by adsorption or other chemical interaction and typically consists of a material that undergoes a change in electrical conductivity, resistance, or other properties upon exposure to the analyzed gas. The electrodes are positioned on the sensing layer to detect changes in their electrical

properties. The heater is provided to heat the element that boosts the sensitivity and response time of the sensing layer. For example, LaCoO_3 has been used to sense through the catalytic oxidation of volatile organic compounds (VOCs). Typical applications of oxide perovskites based gas chemiresistive sensing action are summarized in Table 1

Table 9.1. Data on detection of substances by perovskite oxides by chemiresistance measurements.

Oxidic Material	molecule analyzed	concentration	Response recovery time(s)	Detection
ZnO-LaCoO ₃	Ethanol	100ppm	2.8/9.7	50 ppb
Sr-LaCo ₃	acetone	50 ppm	20/25	-
Ce-LaCoO ₃	ethanol	100ml.min	16/8	
Ce-LaCoO ₃	Ethanol	40 ppm	17/32	0.57 ppm
LaCrO ₃	CO/CO ₂	1000 ppm	28.ND-35/70	-
TiO ₂ -LaCrO ₃	Petrol/CO ₂	500 ppm	2147-20/48	-
La-BaTiO ₃	NO ₂ /NH ₃	200 ppm	2/5-2/40	-
rGO-ZnSnO ₃	acetone	50 ppm	4/27	10 ppm
ppy-ZN ₂ SnO ₄	NH ₃	100 ppm	35/26	0.1 ppm
Pani-LaFeO ₃	CO ₂ -humidity	10.000	164/98	-
GO-SrTiO ₃	NO ₂	1 ppm	300/900	72 ppb
TiO ₂ -SrTiO ₃	Ethanol	50 ppm	0.4/50	2.94 ppb
Pd-SrTiO ₃	Ethanol	50 ppm	15/37	-

9.3 Optical sensors using halide perovskites

Halide perovskites have found applications as optical materials, and their remarkable sensitivity to environmental changes, such as temperature, humidity, and analytes, makes them an appealing option for chemical sensing applications. Optical sensors utilize fluorescent molecules to detect the presence of target analytes. A standard fluorescent sensor comprises three main components: a fluorescent material probe, a light excitation source, and a detector. The fluorescent material probe is a compound that selectively binds to the target analyte and undergoes a change in its fluorescence properties upon binding. When the probe is excited by a light source, the changes in fluorescence properties are recorded. To measure the fluorescent signals, a detector like a fluorescence spectroscopy or light collection device is used.

9.3.1 Gas optical-sensor

Halide perovskites possess unique structural and opto-electronic properties, making them a promising candidates for gas sensing applications. Optical sensors that rely on fluorescence (FL) changes offer several advantages, such as working at room temperature, low energy consumption, and rapid response times. Various types of gas and vapor sensors have been developed utilizing organo-metal halide perovskite materials, including SO₂, NH₃, methylamines gas and H₂S. The main application of perovskite based optical sensors are summarized in Table 9.2.

Table 9.2. Summary of the characteristics of the halide perovskite-based gas optical sensors

Halide perovskite-based gas optical sensors Material	Target	Effect	Linear range	Detection limit
CH ₃ NH ₃ PbBr ₃ @SiO ₂ gel	SO ₂	FL Quenching	0–10 ppm	0.155 ppm
CsPbX ₃ film	Ammonia gas	FL enhance	20–200 ppm	- /
CH ₃ NH ₃ PbBr ₃ TiO ₂	Ammonia gas/ amine vapor	Turn-on FL	5–100 ppm	0.92 ppm
CH ₃ NH ₃ PbBr ₃ fiber	Methylamine gas	FL enhance	5–200 ppm	0.8 ppm
CH ₃ NH ₃ PbBr ₃	Methylamine gas	FL enhance/ Shift	1–95 ppm	70 ppb
CsPbBr ₃	H ₂ S	FL Quenching	0–100micro M	0.18 micro M
CsPbBr ₃	Thiophen sulfides	FL Quenching	10–50 ppm	-

9.4 Optical sensors for the chemicals in the solution

9.4.1 Ionic sensing

Pollution can arise from various types of inorganic compounds, with the mode of contribution contingent on the compound in question and its source. For instance, lead, mercury, cadmium, and arsenic, which are heavy metals, can pollute the environment via industrial processes, mining operations, and the use of pesticides and fertilizers. Herbicides and pesticides commonly contain inorganic compounds such as copper, arsenic, and zinc, which can cause soil and water pollution, adversely affecting humans and wildlife. Cu²⁺ is crucial for maintaining human health, but excessive intake of Cu²⁺ can have negative impacts on the body, including gastrointestinal problems and damage to the liver or kidneys. As a result, it remains vital to accurately measure the levels of Cu²⁺ in both drinking water and the environment.

Table 9.1: Table of material properties and detection limits.

Material	Target	Effect	Linear range
Eu ³⁺ -doped Cs ₃ Bi ₂ Br ₉	Cu ²⁺	FL quenching	5 nmol to 3000 nmol
CsPbBr ₃ added OAm	Cu ²⁺	FL quenching	0.01 nmol to 1 nmol
Ag ₂ BiI ₅ -OAm	Cu ²⁺	FL quenching	0.01 nmol to 1 nmol
CsPbBr ₃ -Zn-MOF	Cu ²⁺	FL quenching	5 nmol to 1000 nmol
(C ₆ H ₅ NH ₃) ₂ Pb ₃ I ₈ · 2 H ₂ O	Fe ³⁺	FL quenching	0.1 nmol to 100 nmol
PEI-OA-MASnBr ₃	Fe ³⁺ /Cr ⁶⁺	FL quenching	5 μmol to 500 μmol
CH ₃ NH ₃ PbBr ₃ @MOF	Cr ²⁺	FL enhancement	2 mmol to 10 mmol
CsPbBr ₃ -Ti ₃ C ₂ T _x MXene	Cd ²⁺	Turn-on FL	0.1 nmol to 0.6 nmol
CsPbBr ₃	Ag ²⁺	FL quenching	50 nmol to 10 000 nmol
CsPbBr ₃	Hg ²⁺	FL quenching	5 μmol to 100 μmol
CsPbBr ₃ -Eu-MOF	Hg ²⁺	Colorimetric	0 μmol to 1 μmol
CsPbBr ₃	Cl ⁻	Emission shift	10 μmol to 200 μmol
CsPbBr ₃	Cl ⁻ /As ³⁺	Emission shift	0.007 μmol to 0.016 μmol / 0.48 ppb to 4.32
CsPbBr ₃	S ²⁻	Ratiometric	0.2 nmol to 15 nmol

9.5 Photoelectrochemical sensor

A photoelectrochemical (PEC) sensor is a device that utilizes light to initiate an electrochemical reaction on the electrode surface, and subsequently monitor changes in the generated electrical

signal due to analyte interaction. The typical structure of a PEC sensor consists of a working electrode, counter electrode, reference electrode, electrolyte, light source, and transducer. The working electrode is coated with a photoactive material that generates photocurrent when exposed to light. When the analyte and working electrode are photo-irradiated, electrons transfer occurs, and the resulting change in photocurrent intensity is recorded. The photoactive compound is a crucial element of the PEC detection system. The counter electrode balances the electrical charge of the working electrode and completes the electrical circuit. The reference electrode is a stable electrode that maintains a constant potential difference to the working electrode, providing a reference point for measuring the electrochemical signal. The electrolyte conveys electrical charges between the working and counter electrodes. The transducer converts the electrochemical signal created at the working electrode into an electrical signal that can be measured. The resulting electrical signals indicate the presence and concentration of the target analyte, making it a valuable sensing technique.

9.6 General Remarks

Accurate control of the morphology and structure of perovskite materials is essential to optimize their sensing properties. The electrical, optical, and stabilizing properties of these materials are substantially influenced by their morphology and structure. Crystallographic orientation, grain size, and surface area are the factors that can affect their sensitivity, selectivity, and response time. With an understanding of the interplay between preparation methods, morphology, properties, and control over morphologies, perovskites could emerge as promising candidates for use in biochemical sensing applications also. Their exceptional photodetection capabilities make them ideal for optical sensors. They show promise for gas-sensing applications due to their great sensitivity for the detection of specific gases when their composition and structure are tailored. However, the stability and toxicity of perovskites present significant challenges. Perovskite based materials are vulnerable to degradation in the presence of moisture and oxygen, which can limit their useful lifespan. Moreover, the presence of lead in some perovskite-based materials poses a significant concern due to its potential harm to both humans and the environment.

9.7 References

[1] The Huy Bui and Joong Ho Shin, Perovskite materials for sensing applications: Recent advances and challenges, *Microchemical Journal* **191** (2023) 108924.

Table 9.2: Table 9.4. The performances of the halide perovskite-based sensors with the organic compounds using optical and photoelectrochemical techniques.

Material	Target	Technique	Linear range	Detection limit
PEGylated CsPbBr ₃	Rhodamine 6G	Colorimetric	0–10 mg/mL	0.01 mg/mL
Cs ₄ PbBr ₆ /CsPbBr ₃	2,4-dinitrophenyl-hydrazine	FL quenching	0.05–30 mg/mL	0.033 mg/mL
CsPbBr ₃ @MIP	Phoxim (Pesticide)	FL quenching	5–100 ng/mL	1.45 ng/mL
CsPbBr ₃ mesoporous silica MIP	2,2-dichlorovinyl dimethyl phosphate	FL quenching	5–25 μ g/L	1.27 μ g/L
CsPbBr ₃ @ β CD-merocyanine	Thiamethoxam	Ratiometric	14.4–62.4 μ M	4.11 μ M
CsPbI ₃	Clodinafop	FL quenching	0.1–5 μ M	34.7 nM
CH ₃ NH ₃ PbBr ₃	Picric acid	FL quenching	1.8–14.3 μ M	0.3 μ M
CsPbBr ₃ @MIP	Patulin	FL quenching	0.2–20 ng/mL	0.027 ng/mL
Cs ₄ PbBr ₆ /CsPbBr ₃	Tetracycline	FL quenching	0.4–10 μ M	76 nM
CsPbBr ₃ @Cs ₄ PbBr ₆ @NH ₂	Tetracycline	Ratiometric	0–5 μ M	12.1 nM
Cs ₂ ZnCl ₄	Norfloxacin	FL enhancement	0.2–50 μ M	0.15 μ M
I-exchanged CsPbBr ₃	Penicillamine	Turn-on FL	5–35 nM	1.18 nM
CdPbBr ₃ @BaSO ₄ -Au	Melamine	Turn-on FL	5–500 nM	0.42 nM
CsPbBr ₃	Benzoyl peroxide	Emission shift	0–120 μ M	0.13 μ M
CsPbBr ₃	Prostate-Specific-Antigen	Colorimetric/FL	-	0.29/0.08 ng/
CsPbBr ₃ -PVDF	Iodine	FL quenching	4–28 μ M	1 μ M
CsPbCl ₃ -mTiO ₂	Alpha-fetoprotein	PEC	0.08–980 ng/mL	30 ng/mL
CH ₃ NH ₃ PbI ₃ @Carbon-PVDF	Cholesterol	PEC	10 ⁻¹³ –10 ⁻⁸ M	2.1 \times 10 ⁻¹⁴ M
CH ₃ NH ₃ PbX ₃ @TiO ₂	Cholesterol	PEC	-	2.5 \times 10 ⁻¹⁰ M
CH ₃ NH ₃ PbI ₃ -MIP	Salicylic acid	PEC	10 ⁻¹³ –10 ⁻⁸ M	1.9 \times 10 ⁻¹³ M
CsPbBr ₃	Alkaline phosphatase	PEC	50–1000 U/L	42.1 U/L
Cs ₃ Bi ₂ Br ₉ -BiOBr	Alkaline phosphatase	PEC	1–500 U/L	0.18 U/L
Cs ₃ Bi ₂ Br ₉ -BiOBr-Au	H ₂ O ₂	PEC	0.002–200 μ M	0.89 nM
CsPbBr ₃ -ZnO	Dihydronicotinamide adenine dinucleotide	PEC	0.1–250 μ M	0.01 μ M
CsPbBr _{1.5} I _{1.5}	Dopamine	PEC	0.1–50 μ M	0.012 μ M

Chapter 10

Preparative Methods for Perovskites

10.1 Introduction

When a material is prepared for a device application, one has to take certain precautions this will also be applicable for the preparation of perovskites. Perovskites can be prepared in various forms like nanocrystalline, bulk, thin films, nanowires, nanotubes, nanocubes, nanorods and in various other configurations.. The particular form depends on its applications. Synthesis can be carried out using particular bottom-up and top down approach. There are several methods to synthesize perovskite materials in different forms such as chemical co-precipitation, microemulsion, hydrothermal, solvothermal, microwave irradiation, spray-pyrolysis, chemical vapor deposition and so on. In this section, we shall briefly consider some of the preparation methods.

10.2 Solid State Reaction

This method is the most common and most often employed method for preparing perovskite materials in powder form. The solid state reaction pathway offers use of a wide variety of raw or starting materials, including oxides, carbonates, (in general precursors).. At room temperature, solids do not react with one another; therefore, it is required to heat them to higher temperatures, typically between 800 and 2000⁰C, for the reaction to take place at a required rate. Consequently, in this method, both the thermodynamic and kinetic elements are crucial. Precursor materials for example BaCO₃ and TiO₂ were combined together to create bulk BaTiO₃, and the mixture was then pulverized with a mortar and pestle to reduce the size of the particle and increase the surface area exposed to the reaction. The crushed powder was calcined in furnace over 900⁰C to form the necessary product. Different wet chemical techniques can be used to overcome the limitations of the traditional solid state reaction method, including high sintering temperature, secondary phase formation, poor ingredient dispersion, high porosity, and big particle size. Due to its higher surface-to-volume ratio and quantum confinement effects, nanomaterials have different properties than those of bulk materials. It is a widely recognized fact that the properties of a bulk material radically alter as it gets closer to the nanoscale. These characteristics are related to the size, shape, and distribution of the particles inside the materials, which in turn are dependent upon the synthesis process adopted.

10.3 Sol-gel auto combustion method

Another name for the sol-gel auto combustion process is low-temperature self-combustion, commonly known as auto-ignition, self-propagation, nitrate-citrate combustion, gel-thermal breakdown technique. This method uses a sol-gel procedure to create a gel out of an aqueous solution of the necessary metal salts (often nitrates or acetates) and organic fuel. The gel is then ignited to cause combustion, producing a fluffy, voluminous end product with a sizable surface area. Fuel is utilized in this method as a complexant to create a homogenous precursor called xerogel. In comparison towards other synthesis techniques, a sol-gel auto combustion approach has advantages since it can precisely manage the composition, purity, least particle aggregation, homogeneity at the microscopic scale, and sintering temperature. Selecting the proper complexant additives is crucial for the production of homogeneous phases. Metal particles of varying sizes can be successfully chelated by complexant agents or fuel, which helps to maintain the specific precipitation needed to maintain compositional homogeneity among the constituents. The complexant substances act as reductants and are oxidized by nitrate ions to produce fuel. Many types of complexant agents are utilized to create perovskite materials. Most commonly used complexants are citric acid ($C_5H_8O_7$), glycine (NH_2CH_2COOH), urea ($CO(NH_2)_2$), ethylene glycol $(CH_2OH)_2$, dextrose ($C_6H_{12}O_6$), acetic acid (CH_3COOH), ascorbic acid ($C_6H_8O_6$), propionic acid (CH_3CH_2COOH) and so on. Tetra butyl titanate ($Ti(OC_4H_9)_4$) or titanium isopropoxide $Ti[OCH(CH_3)_2]_4$ can be chosen as a precursor (for Ti^{4+} ions) due to the fact that it is a transition metal alkoxide. It is very reactive because it contains strongly electronegative groups that keep the metal in the highest oxidation state and enable nucleophilic attack on the metal. These alkoxide precursors are highly electrophilic, making them less resistant to condensation, hydrolysis, and other nucleophilic processes. Additionally, the group R from $Ti(OR)_4$ influences the gel's shape (size and surface area of the crystallites) and crystallization behavior. Controlling the condensation path and polymer development requires chemical modification of the transition metal alkoxide with chelating ligands. Tetra butyl titanate was chelated with ethanol (1:2) to produce a highly condensed product and to aid in the gelification process. A unidimensional polymer is produced when too much water is introduced to $(Ti(OC_4H_9)_4)$ -ethanol, which causes the O-R ligands to be hydrolyzed preferentially. The metal nitrate to citric acid molar concentration was taken to be 1:5 in accordance with the rules of propellant chemistry, which take into account the oxidizing and reducing valencies of various components. Tetra butyl titanate solution was initially added to a citric acid aqueous solution with a pH of 8, which was then brought to the desired level by adding the necessary amount of ammonia. A yellowish translucent liquid that is designated as solution "A" was produced after being agitated at $80^\circ C$ for 1 hour. Inorganic compounds (in this case, barium nitrate) were simultaneously dissolved in distilled water while being continuously stirred; the resulting solution, designated as solution "B," is the result. Then, mixtures of solutions "A" and "B" were added. Ammonia was used to bring the pH level to 7 and maintain it there until a translucent liquid was obtained. The solution's viscosity progressively rose after 3 hours of nonstop stirring, after which a stable translucent sol formed. The creation of the gel is started by continuous heating to $110^\circ C$. Viscous gel becomes dry gel when heated and constantly stirred. It was discovered that the nitrate-citrate gel's combustion process was autocatalytic, and experimental results revealed that the dried gel made of metal nitrates and citric acid exhibited self-propagating combustion behavior. The entire combustion process was completed in a matter of minutes. To produce the nanocrystalline powders, the resulting powders were dried, crushed, and annealed at $900^\circ C$ for 5 hours in a muffle furnace.

10.4 Co-precipitation method

The precipitation of metal salts is a method which is frequently used for the synthesis of simple oxides. Precipitation occurs after adding a chemical reagent which decrease the solubility limit. Co-precipitation happens when different cations in solution precipitate simultaneously.

For the simultaneous precipitation of all cations and obtaining perfect homogeneous products it is essential to control the temperature, concentration, pH and solution homogeneity. Ammonia, ammonium oxalate, urea and ammonium carbonate are some of the popular reagents used for precipitation. The formation of oxide compounds, insoluble in solutions occurs due to the thermal decomposition of the hydroxides, organic or carbonates salts.

10.5 Hydrothermal synthesis

The hydrothermal synthesis is to carry out the reaction in the aqueous solution or suspend the precursors at high temperature and pressure. Crystalline powders can be obtained in this method without calcination. This method previously used to synthesize and check the thermodynamic constancy of BaTiO_3 and other perovskites but now the particle size and shape can be changed through controlling the reaction temperature, pH time and concentration of reactants. Recently, BaTiO_3 started to be synthesized at low temperatures using this method by using an electric field in a hydrothermal shell at specific temperatures (100 and 200°C), after this some researcher manage to synthesize it using an electric field to further reduction of the hydrothermal synthesis temperature. This method can be described as follows: The reaction occurring in solvents contained in sealed condition by heating them to their critical point under autogenous pressure is called the hydrothermal/solvothermal process. In this method, the solutions are subjected to high pressure and temperature. The main advantage of this method is the preparation of good-quality crystals while controlling their composition. In 1:2 mol ratios, the divalent and trivalent transition metal salts are mixed together To get a homogeneous solution, mix the organic solvent with constant stirring in the solution. Stirring this solution at room temperature yields a low-viscous gel. Then, the solutions are brought into the sealed vessel, commonly called an autoclave (bomb). By heating, an autogenous increase in pressure takes place, which will directly raise the solvents above their boiling points. The temperature adjustment and time are dependent on the type of nano-particles to be synthesized. After the hydrothermal treatment by varying the time and temperature, the sample thus prepared is filtered and washed, followed by drying, which gives us the desired crystalline powder. This is a method for the preparation of the least-size nanoparticles, which can be applied in the biological field. Through the selection of suitable solvents and also by varying factors like temperature, pressure, pH, aging time, the concentration of reactants, and the time of the reaction, the controlled and desired size, morphology, and surface chemistry of nanoparticles will be produced. Highly homogeneous nanoparticles can be achieved by using this technique. Without post-annealing treatments, the development of the least-size nanoparticles in the desired crystalline phase at relatively lower temperatures is possible with this method. This method can be used to prepare single crystals, zeolite and other porous solids.

10.6 Pechini Method

The polymeric precursor method, also known as the method of mixed liquids, is a synthesis method that allows the synthesis of oxides with excellent control of the stoichiometry of reac-

tion products and reactants. This method shows high reproducibility and homogeneity of the reaction mixture.

The principle of this method involves the construction of a chelate by the reaction of charged cations, introduced into the system as soluble salts with a carboxylic acid. The resulting solutions contain metal salts and citric acid, which, when mixed with the desired ethylene glycol and heated to 80 °C to 100 °C, give a clear solution. Further heating to a higher temperature (150 °C to 250 °C) leads to the occurrence of a condensation reaction involving COOH and OH groups, resulting in the formation of a polyester resin in which metallic cations are uniformly distributed in the resin mass.

10.7 Microwave Synthesis

Microwaves are gradually used as a fresh synthetic way in solid State Chemistry. The usage of microwave irradiation is a hopeful alternative heat source for the synthesis of perovskite oxides. This method offers a time savings and massive energy when compared to the other method of ceramic synthesis. Microwave synthesis of perovskite oxides can be achieved by numerous procedures such as Joining microwave heating with other synthetic techniques such as sol-gel or combustion, Irradiation of a solution in an autoclave and Direct irradiation of a mixture of the solid reactants.

There are two methods of microwave synthesis, these are microwave-assisted hydrothermal synthesis and solid-state microwave, the solid-state microwave is narrow to “simple” compositions only while the combining of microwaves with other methods such as combustion, hydrothermal synthesis, or sol-gel permits for enhanced stoichiometric control of complex doped phases.

Joining solvothermal synthesis and microwave heating result in novel morphologies and metastable phases. Perovskite oxide materials properties as superconducting, dielectric, ferromagnetic, ferroelectric, and multiferroic systems play very important rule in there synthesis using microwave techniques The simplicity and speed of microwave synthesis so it became attractive for Pb-containing perovskite, because it minimizes the Pb-loss.

There are many methods to prepare solid state materials and most common ones are outlined in this section. other methods based on other probe techniques can also be used to prepare solid state materials. In the figure below the sysnthesis methods are shown diagrammatically.

In this chapter, only the commonly employed methods are outlined. There are many other possible methods and the reader is directed to look into the literature for these special methods of preparing perovskite materials.

10.8 References

- (1) Shan-Shan Rong, M. Bilal Faheem , and Yan-Bo Li, Perovskite single crystals: Synthesis, properties, and applications, *Journal of Electronic Science and Technology* **Volume 19**, Issue 2 , June 2021, 100081.
- (2) Eman Abdul Rahman Assirey , Perovskite synthesis, properties and their related biochemical and industrial application, *Saudi Pharmaceutical Journal*, **Volume 27**, Issue 6 , September 2019, Pages 817-829.
- (3) Junjiang Zhu, Hailong Li, Linyun Zhong, Ping Xiao, Xuelian Xu, Xiangguang Yang, Zhen Zhao and Jinlin L, Perovskite Oxides: Preparation, Characterizations, and Applications in Heterogeneous Catalysis, *ACS Catalysis* **Vol 4** Issue 9, 2917.
- (4) Dinesh Kumar, Ram Sagar Yadav, Monika, Akhilesh Kumar Singh and Shyam Bahadur Rai,

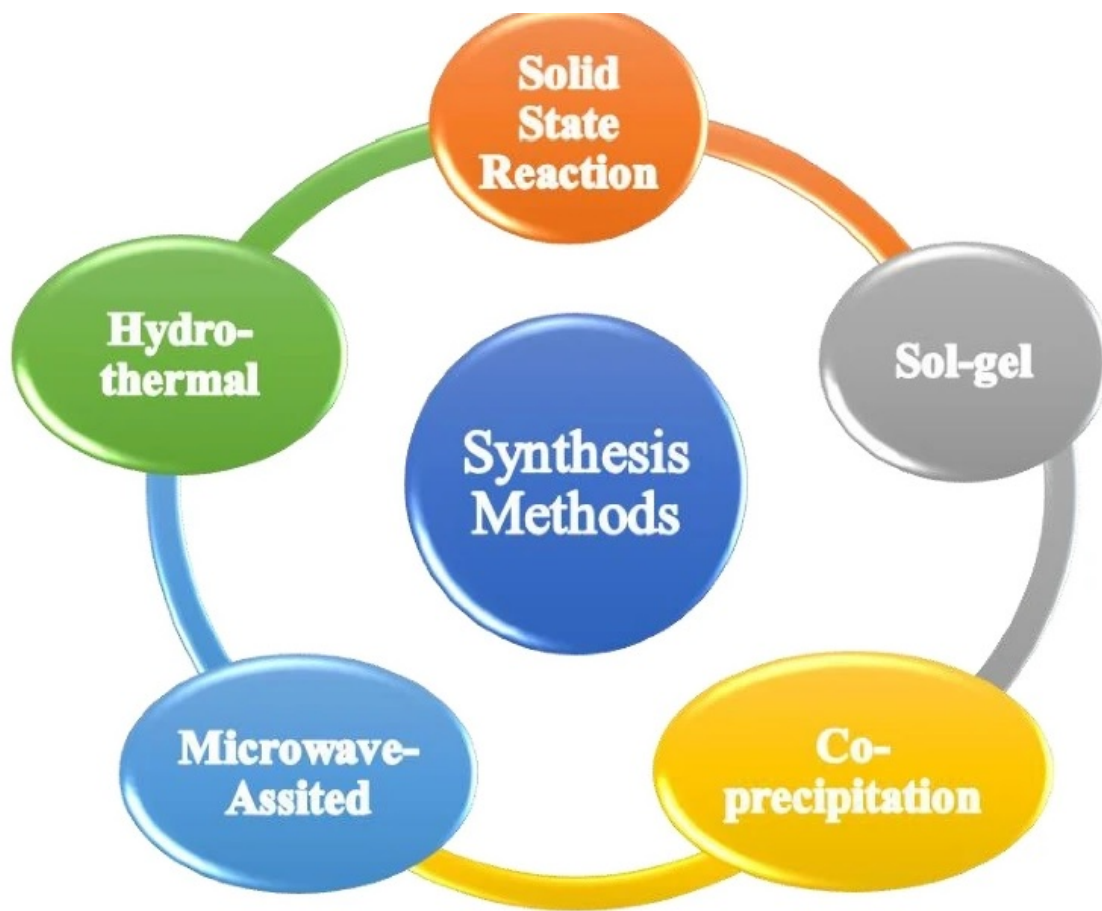

Figure 10.1: A visual depiction of various innovative techniques for synthesizing perovskite materials, Sahil Kumar, Vishal Sharma, Neha Kumari, Gun Anit Kaur, Anirban Saha, Sapna Thakur and Mamta Shandilya, Recent advances in perovskite materials: exploring multifaceted properties for energy harvesting applications, Ionice, July 2024

Synthesis Techniques and Applications of Perovskite Materials, from the edited volume, Perovskite Materials, Devices and Integration, Edited by He Tian, DOI: 10.5772/intechopen.86794. (5) Weiren Xia, Yao Lu and Xinhua Zhu, Preparation Methods of Perovskite-Type Oxide Materials, in Revolution of perovskite, Synthesis, Properties and Applications (Eds:Narayanasamy Sabari Arul, Vellalalayam Devaraj Nithya (Springer) (2020).

Chapter 11

In Retrospect

11.1 Introduction

Material Science is an evolving field though materials are known for a long time. This time span is due to the introduction of appropriate tools for the structural elucidation. Similar situation existed for the field of Surface Science since vacuum technology and detection sensitivity have to reach a mature level. Both these two fields have been progressing at rapid rate from 1950 on wards.

The art of Materials design and synthesis have turned out to be scientific just like catalysis which turned purely science based with the advent of surface analytical tools. In spite of all these advancements, still, there is some gap when it comes to select a particular materials for a specific application especially in view of the anxiety to improve the performance of the existing materials. In view of this situation, it is necessary that our learning society must be equipped with appropriate armour to face this challenge. In order to achieve this goal and also to be of help to our learning society, it would be better if some model system study is initiated and in this sense, this exercise is one such attempt.

Among the various types of materials, perovskites occupy an unique place since, these systems are susceptible for substitution on all the three sites in ABX_3 composition both partially and fully. Let us consider as example only the oxide perovskites. In the following flow chart (Fig.11.1.), the variety of materials that can be generated are shown.

It is recognized that with different anions (and possibly with some vacancy also) the possible number of materials can be enormous. In fact, among material scientists Perovskites are considered to be universal material, so that any desired application cure for all ills can be fulfilled with these materials. This aspect has already been demonstrated in various places. It is therefore considered to consider this system as model system to initiate learning community to Material Science.

As expected, it is beyond doubt that perovskites can exhibit varied properties and hence find a wide application. However it must be realized that these materials will revolutionize certain critical applications the most notable one among them are the solar cells, a device employed to harness solar energy to useful form of energy (electricity) to the human society.

It is true that there may be other compelling reasons for initiating this exercise. As we all know, the human society is anxious about energy and environment. Any material that can provide solutions to these two needs of human society should receive considerable attention and in this sense, Perovskite materials find the prime place. For example the efficiency of solar

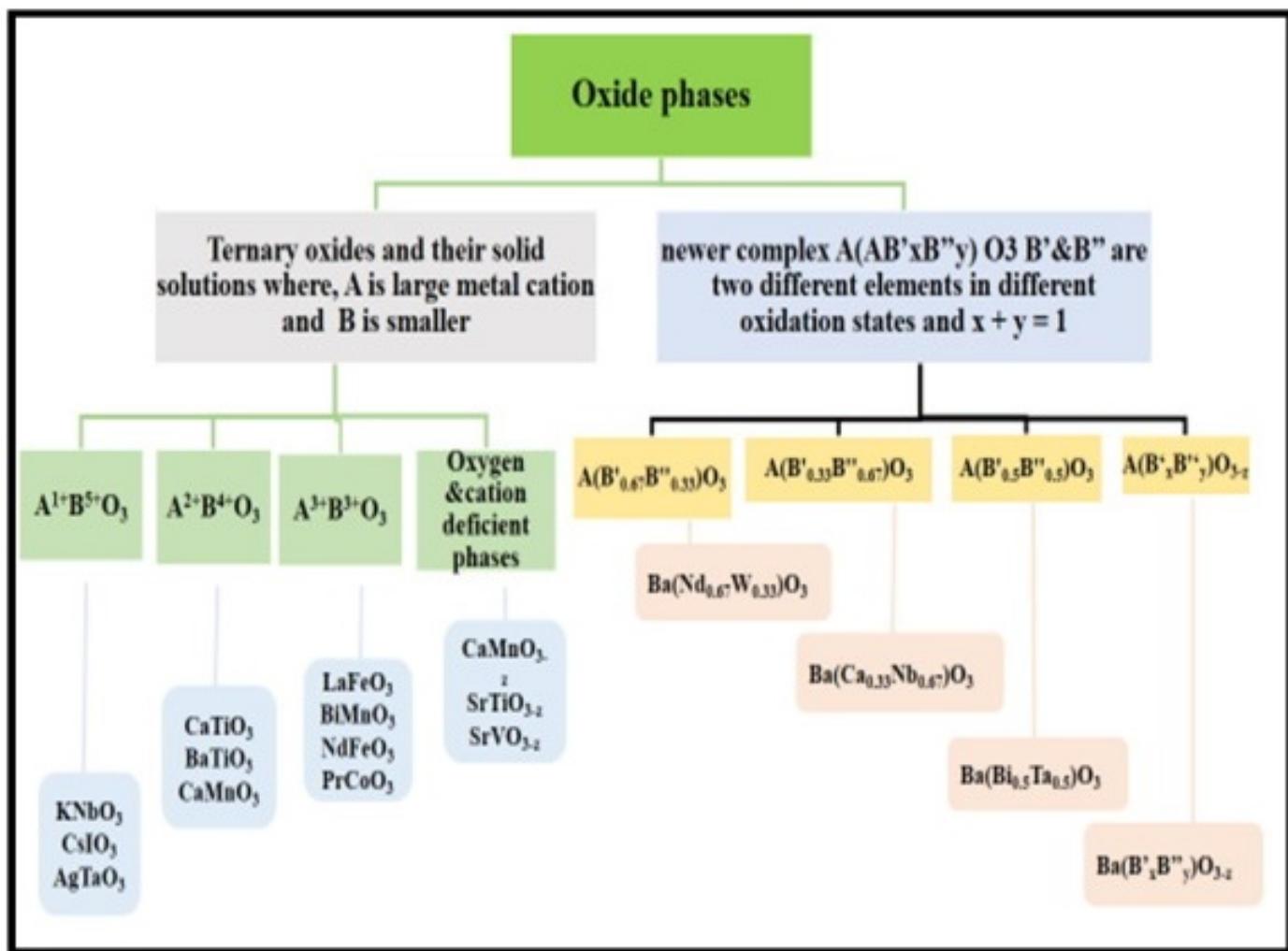

Figure 11.1: Classification of perovskites (ABX_3) structure in a flowchart form.

cells reached 25% already with the use of perovskite (HOIP) materials and this has also been dealt with in a separate chapter and it is hoped that in energy conversion devices will undergo a radical change in the near future.

11.2 Future Prospects

There are some projections regarding the deployment of photovoltaic devices in the coming years. Among them the main projections are

- Accelerated solar PV deployment coupled with deep electrification could deliver 21% of the CO_2 emission reductions (nearly 4.9 gigatonnes annually) by 2050.
- Solar PV could cover a quarter of global electricity needs by mid-century, becoming the second largest generation source after wind. In view of these projections perovskite materials have bright future. It must be stated that solar cells are only one example for perovskite materials.

- Asia would continue to dominate solar PV use, with over 50% of installed capacity, followed by North America (20%) and Europe (10%).
- Solar PV project costs, already below marginal fossil-fuel costs in global terms, are set to decline further in the decades ahead.
- Mobilising finance will be key, with estimates implying a 68% increase in average annual solar PV investment until 2050.
- Solar PV is a fast-evolving industry, with innovations along the entire value chain driving further, rapid cost reductions. Floating PV is a prime example, with global cumulative installed capacity exceeding one gigawatt in 2018 and clear potential for rapid growth.
- Rooftop solar PV systems have spread rapidly thanks to supporting policies, such as net metering and fiscal incentives.
- Energy transformation brings socio-economic benefits. The global solar industry could employ over 18 million people by 2050

World wide increase in solar power generation over the years is pictorially shown in Fi.11.2.

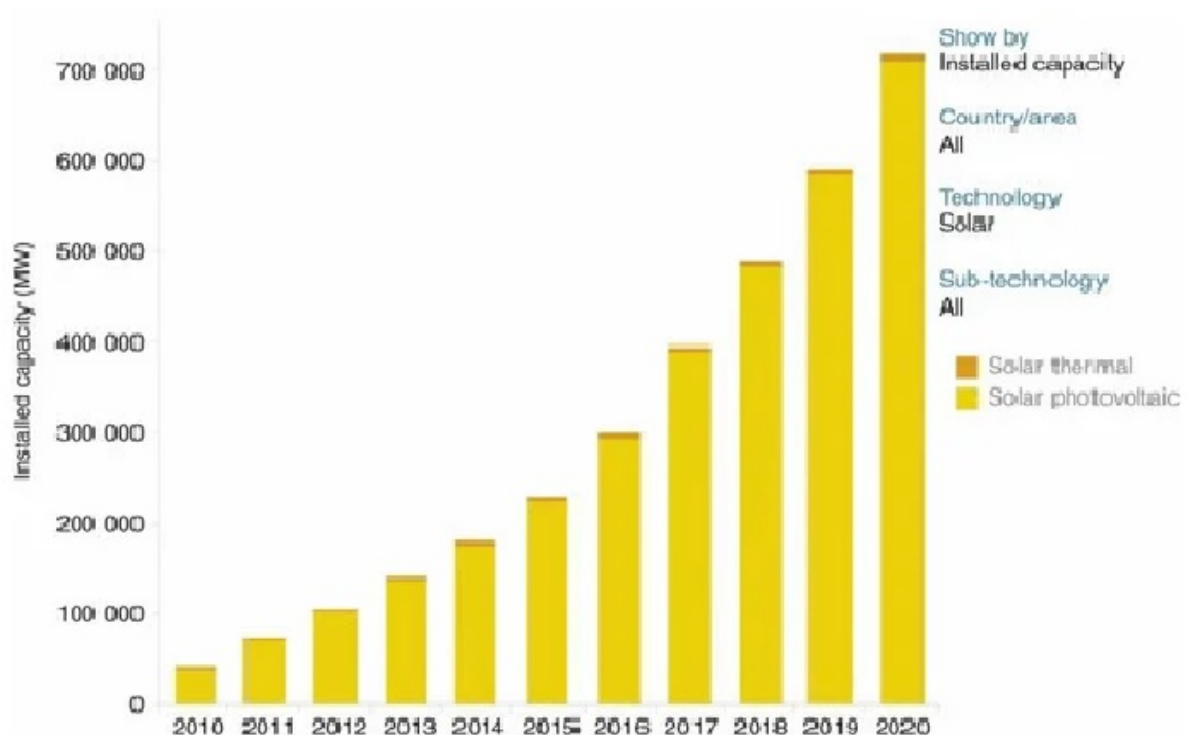

Figure 11.2: Worldwide increase in the installation capacity of solar energy (Reproduced from Maka, A.O.M.; Alabid, J.M. Solar energy technology and its roles in sustainable development. Clean Energy 2022, 6, 476–483.)

In the face of increasing environmental concerns and the anxiety to reduce greenhouse gas emissions, solar energy, especially PV technology, is emerging as a player in the global energy market. The development in harnessing solar power is remarkable. This development

is aided by technological innovation, increased efficiency, as well as cost reduction. Clearly in the global scene, one set of countries have taken the lead through government policies. Some of the other countries (so called developing ones) find an opportunity in solar energy to meet their energy demands sustainably. With increasing affordability, policy support, and a commitment to sustainable development, these nations stand poised to expand their solar energy capacities. The socio-economic implications of solar energy deployment are substantial, ranging from job creation and industrial development to an enhanced quality of life. It can well be projected that solar energy as the primary global electricity source by 2050. The journey of solar energy is not merely a technological evolution; it is a shift towards a more resilient, equitable, and environmentally conscious energy source.

It is therefore clear that in other spheres of activity like sensing power, fuel production (mainly hydrogen), communication devices (microwave devices and cell phones) and many other necessary components of life will undergo substantial changes by the use of perovskites. It is with that hope note we embarked on this exercise.

11.3 Reference

[1] Amal Bouich, Inmaculada Guaita Pradas, Mehwish Aziz Khan and Yousaf Hameed Khat-tak. Opportunities, Challenges, and Future Prospects of the Solar Cell Market, *Sustainability* 2023, **15**(21), 15445; <https://doi.org/10.3390/su152115445>

Chapter 12

Appendix

In the Web, there are many on-line presentations from which one can gather valuable information on this class of materials and some recent(?) of them are listed

- (1) Perovskites: Ancient Structure, Modern Applications [2020]
- (2) Perovskites: Ancient Structure, Modern Applications [2020]
- (3) Perovskite solar cells (2018)
- (4) Perovskite solar cells (2019)
- (5) Perovskite solar cell materials: Introduction , structure(2020)
- (6) The next generation of Solar: Perovskite Tandem cells (2024)
- (7) Perovskite solar cells Major new breakthrough (2022)
- (8) Are perovskite cells A game changer to solar energy (2024)
- (9) The perovskite crystal structure (2020)
- (10) Nano-structured perovskites for LEDs and Solar cells (2020)
- (11) Halide perovskites nanocrystals 2021
- (12) understanding perovskites and its uses (2016)
- (13) Introducing perovskite solar cells to undergraduates (2015)
- (14) Dielectric properties in hybrid and inorganic perovskites (2017)
- (15) Perovskites breakthroughs are the future of solar (2024)]
- (16) A site doping and B site doping in Perovskite structure(2024)
- (17) Determine chemical formula for perovskite structure (2023)
- (18) The making perovskite solar cells (2020)
- (19) The promise of perovskite solar cells (2022)
- (20) Solar energy advances using perovskites (2023)
- (21) The wonderful world of perovskites(2017)
- (22) An Introduction to Perovskites (2018)
- (23) Everything you ever wanted to know about perovskite (2017)
- (24) Detailed protocol for fabrication of perovskite solar cells(2021)
- (25) Perovskite Solar Cells Surpass 20% Efficiency(2016)
- (26) Perovskite solar cells made simply (2014)
- (27) Spincoating for perovskite solar cells (2021)
- (28) How solar power works? ()
- (29) Constructing a perovskite solar cell (2015)
- (30) Perovskite Solar Cell - Frontier Energy Solution (2017)
- (31) Blade Coating of Hybrid Perovskite Solar Cells - ACS Energy Letters (2018)
- (32) Spin-on- patterning process of perovskite thin-film(2017)
- (33) Spin-on- patterning process of perovskite thin-film(2017)
- (34) Most efficient Solar Cells and Panels in 2019
- (35) Most efficient Solar Cells and Panels in 2020

In this appendix, we have gathered some of the configurations of perovskite materials employed in various devices for knowledge and also for practice purpose only. All of them are from literature

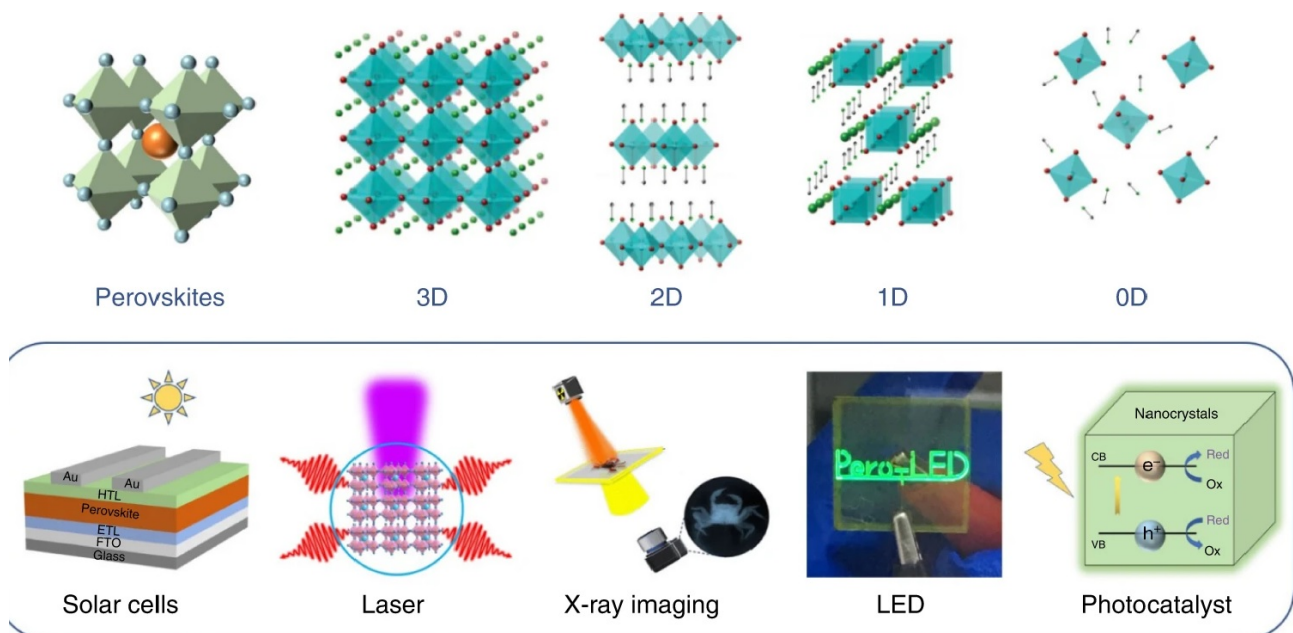

Figure 12.1: Pictorial representation of Dimensionality of Perovskites and the major applications

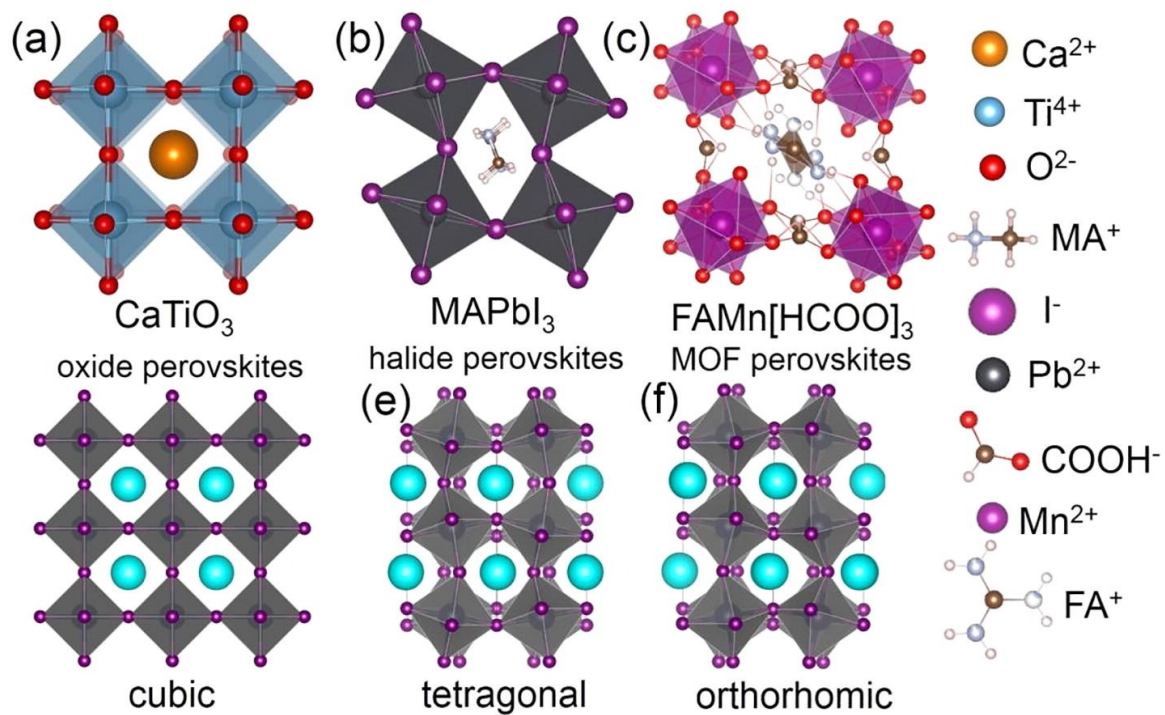

Figure 12.2: Classification of perovskite compounds in terms of composition and crystallography. Crystal structures of (a) CaTiO_3 , (b) MAPbI_3 , and (c) $\text{FAMn}[\text{HCOO}]_3$ as representative examples of ABO_3 -type oxide, ABX_3 -type halide and MOF perovskites, respectively. Typical crystal structures of perovskite compounds: (d) Cubic, (e) tetragonal, and (f) orthorhombic..

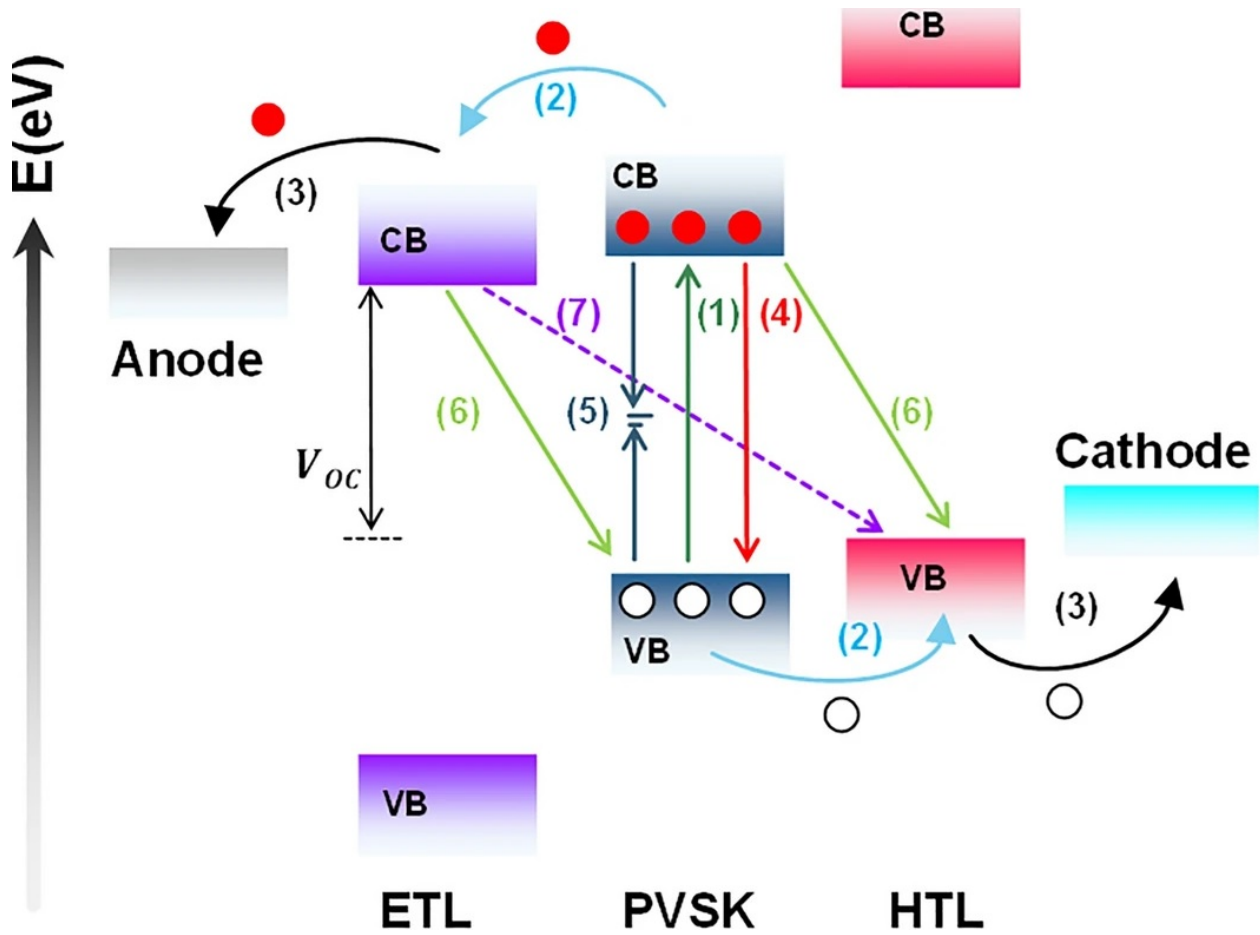

Figure 12.3: Pictorial representation of a perovskite solar cell . The numbers show the sequence of events taking place on irradiation. adopted from Ref.

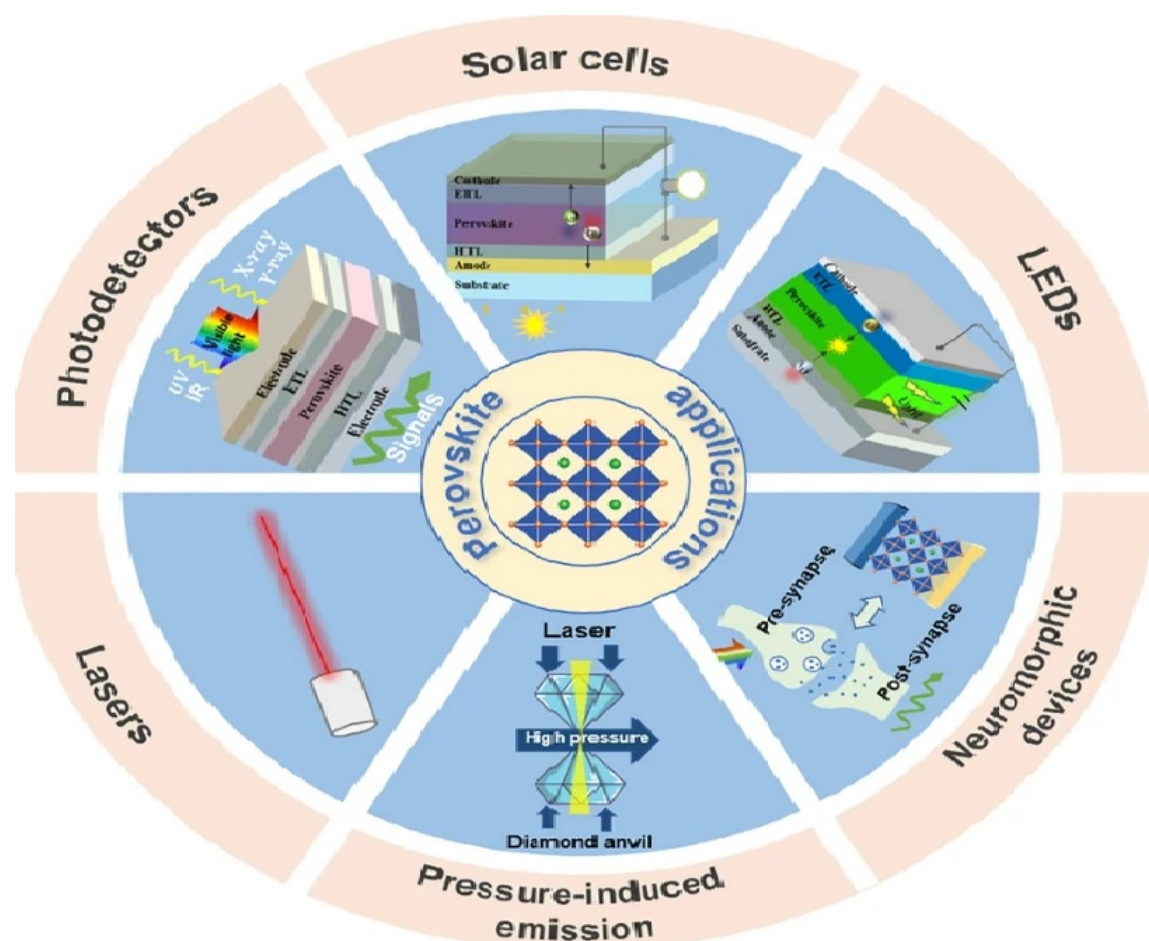

Figure 12.4: Major applications of Perovskite Materials in pictorial form, Lixiu Zhang, Luyao Mei, Kaiyang Wang, Yinhua Lv, Shuai Zhang, Yaxiao Lian, Xiaoke Liu, Zhiwei Ma, Guanjun Xiao, Qiang Liu, Shuaibo Zhai, Shengli Zhang, Gengling Liu, Ligang Yuan, Bingbing Guo, Ziming Chen, Keyu Wei, Aqiang Liu, Shizhong Yue, Guangda Niu, Xiyan Pan, Jie Sun, Yong Hua, Wu-Qiang Wu, *Advances in the Application of Perovskite Materials*, Nano Micro Letters, 15 (2023)

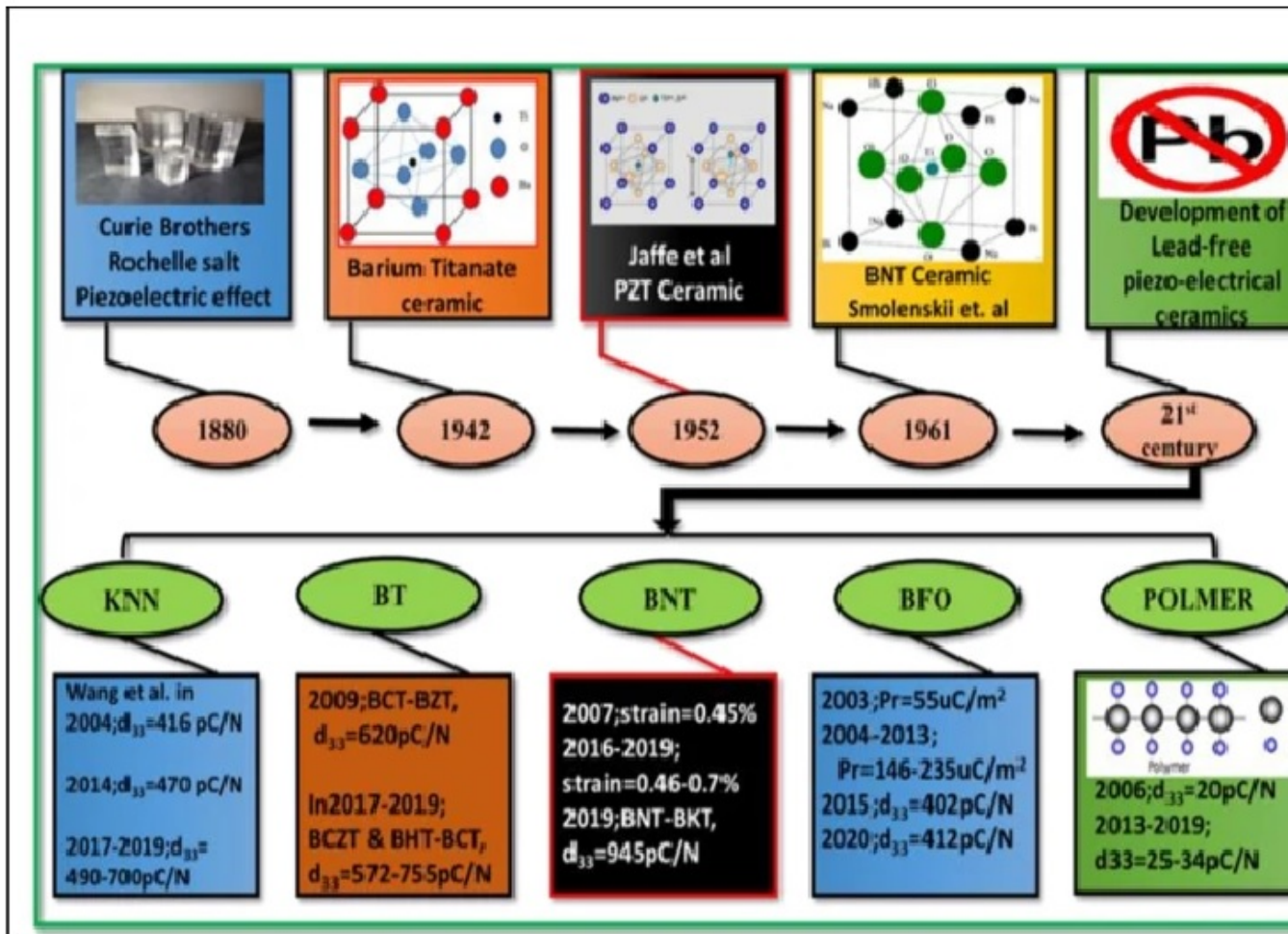

Figure 12.5: History of the evolution and key milestones in the development of piezoelectric materials, Sahil Kumar, Vishal Sharma, Neha Kumari, Gun Anit Kaur, Anirban Saha, Sapna Thakur and Mamta Shandilya, Recent advances in perovskite materials: exploring multifaceted properties for energy harvesting applications, Ionice, July 2024

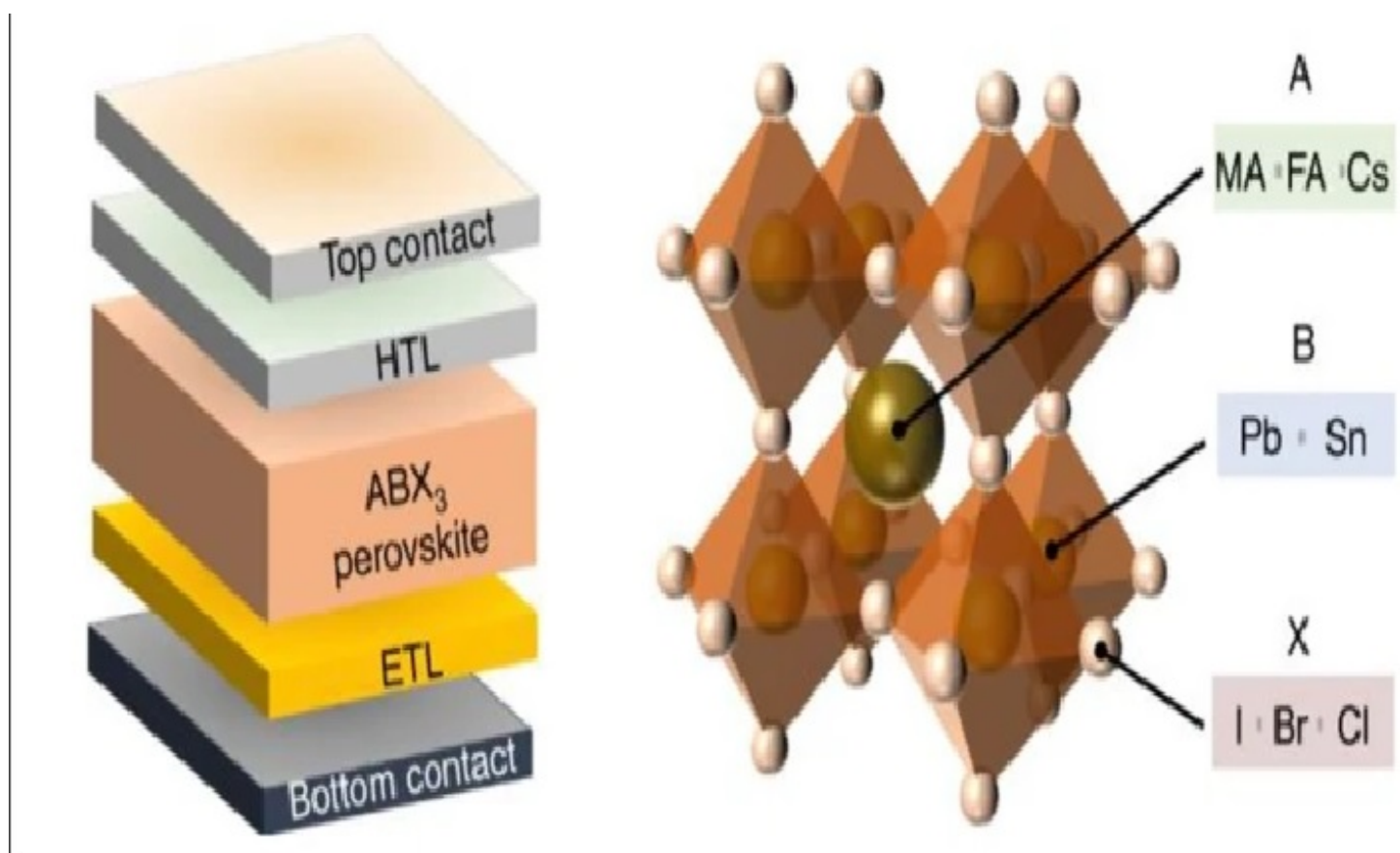

Figure 12.6: Schematic representation of perovskite solar cell, Sahil Kumar, Vishal Sharma, Neha Kumari, Gun Anit Kaur, Anirban Saha, Sapna Thakur and Mamta Shandilya, Recent advances in perovskite materials: exploring multifaceted properties for energy harvesting applications, Ionics, July 2024

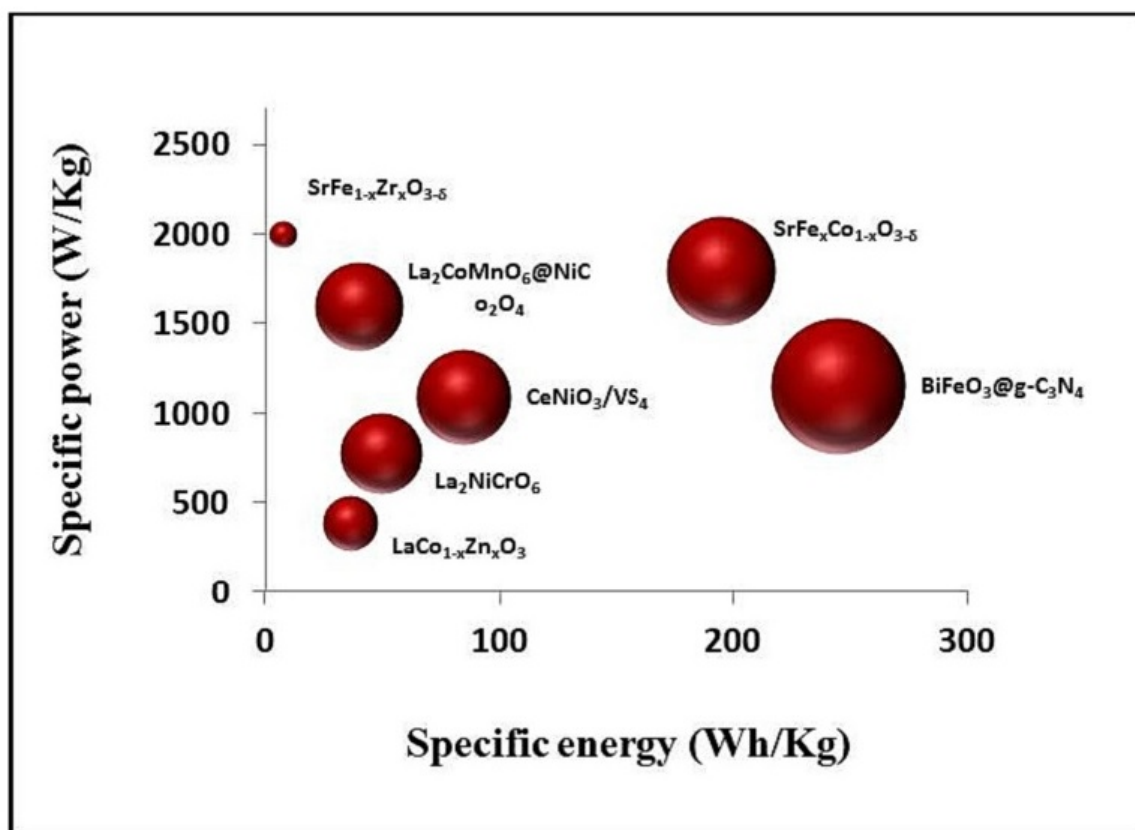

Figure 12.7: Performance metrics of Perovskite oxide supercapacitor materials. reproduced from Vyshakh Viswanath N, Johnbosco Yesuraj, Manickam Ramesh, Kibum Kim, Krishnendu Biswas, Fundamental aspects of perovskite oxides as an emerging material for supercapacitor applications and its anion intercalation mechanism - Review, *Journal of Energy Storage*, Volume 78, 1 February 2024, 109968

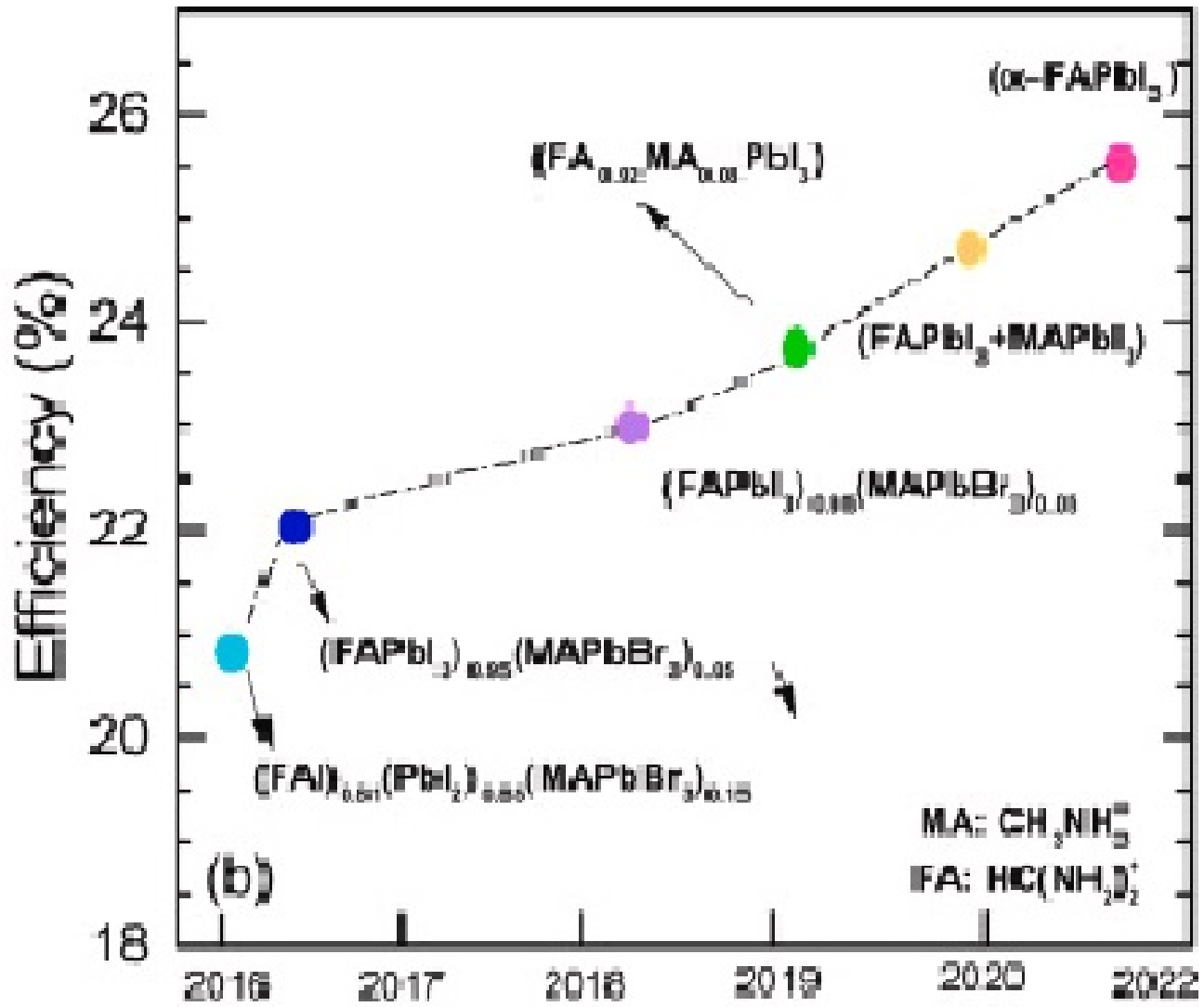

Figure 12.8: The roadmap with the highest efficiencies of different perovskite solar cell technology certified by the NREL, 2019.



Figure 12.9: Key parameters for high performance perovskite oxide material (reproduced from Vyshakh Viswanath N , Johnbosco Yesuraj, Manickam Ramesh , Kibum Kim, and Krishnendu Biswas, Fundamental aspects of perovskite oxides as an emerging material for supercapacitor applications and its anion intercalation mechanism - Review, *Journal of Energy Storage*, Volume 78, 1 February 2024, 109968)

Chapter 13

INDEX

A site cation
B site cation
Electron transporting Layer (ETL)
Ferroelectricity
fuel cells
Goldschmidt's Tolerance Factor
Hole transporting layer (HTL)
Memory Devices
Opto Electronic Property
Perovskite solar cell (PSC)
Piezoelectricity
Pyroelectricity
solid oxide fuel cells
superconductivity
Thin film capacitors
X anion