



Physicochemical Mechanistic Studies on Photocatalysis–Extension of Semiconductor Photoelectrochemistry Concept beyond Its Limitation

Bunsho OHTANI*

Institute for Catalysis, Hokkaido University, Sapporo 001-0021, Japan

* Corresponding author: ohtani@cat.hokudai.ac.jp

ABSTRACT

Heterogeneous photocatalysis, as well as photoelectrochemical reaction, with semiconductor materials has been interpreted and discussed using so-called “band-structure model” as a leading principle since the 1970’s. However, this band-structure model shows only thermodynamics of photocatalytic reactions and no kinetic information is available. Furthermore, the model does not reflect the surface and size of photocatalyst materials, since band structure is of bulk, and thereby the photocatalyst materials are not identified. In this review, works by a group of the present author on physicochemical mechanistic studies on multielectron transfer kinetics and energy-resolved distribution of electron traps to go beyond the band-structure model is introduced.

© The Electrochemical Society of Japan, All rights reserved.

Keywords : Heterogeneous Photocatalysis, Thermodynamics and Kinetics, Band-structure Model, Titanium(IV) Oxide

1. Electrochemical Photolysis of Water at a Semiconductor Electrode

When seeing back the author’s research history, a famous paper (called the “Honda-Fujishima Effect” paper in Japan (though the actual order of authors in the paper was “Fujishima and Honda”.) entitled “Electrochemical Photolysis of Water at a Semiconductor Electrode”¹ seemed to lead to or even decide his field to be heterogeneous photocatalysis. This paper has suggested probably for the first time that water can be split into hydrogen and oxygen by photoirradiation. Although many recent papers have cited this paper as an origin of heterogeneous photocatalysis studies, this paper cannot be the origin in a general bibliographic sense since there had been already published many papers on reaction by solid materials under photoirradiation, i.e., “heterogeneous photocatalysis” (Probably the phenomena related to heterogeneous photocatalysis had been observed in the nineteenth century.) and in fact there were no terms such as “photocatalysis” and “photocatalytic reaction” in the paper.^{2,3} Then, why did this paper give high impact in science to make a lot of researchers, especially chemists including the present author, start working in the field of photocatalysis and photoelectrochemistry? The author thinks that it is because this paper clearly showed that even positive Gibbs energy-change (ΔG) reactions can be driven by irradiation of solid material, i.e., photocatalysts or photoelectrodes, while papers before publication of this paper had reported negative- ΔG reactions which may proceed spontaneously without photoirradiation, e.g., oxidation of hydrocarbons under aerobic conditions.^{3–5} Photosynthesis by plants, an example of such positive- ΔG reactions, had been already known at that time, but the photoelectrochemical system using a semiconductor electrode might be the first example of “artificial photosynthesis-like reactions” (In a strict chemical sense, “synthesis” must include a process (processes) to make new bonding of atoms especially carbon atoms and water photolysis does not produce new carbon-carbon bonds.). This might be striking since fuel, chemical energy, could be prepared only by solar photoirradiation of a solid photocatalyst, which is not, ideally, changed during the course of reaction.

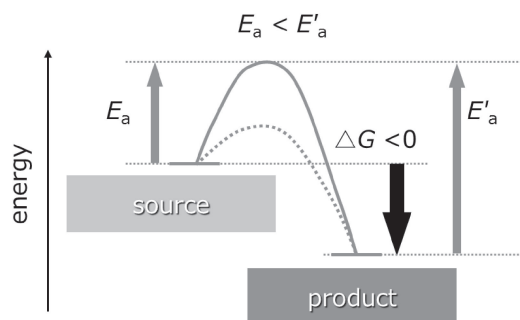

Figure 1. Energy diagram of ordinary chemical reaction as an equilibrium of “source” and “product” with Gibbs-energy change (ΔG). Even if energy greater than the activation energy for backward reaction (E'_a) is given, forward reaction with lower activation energy (E_a) proceeds faster to result in forward (negative ΔG) reaction. To interpret photoinduced process of positive ΔG , alternative explanation, e.g., band-structure model, is needed.

2. Band-structure Model: Thermodynamics of Heterogeneous Photocatalysis

Then, why can semiconductor photocatalysts and electrodes drive even positive- ΔG reactions? This has been explained (and it is believed as a common sense in this field) as that an electron in an electron filled valence band (VB) is excited into an empty conduction band (CB) by photoabsorption with light of energy greater than the energy difference between VB top and CB bottom, i.e., bandgap, leaving a positive hole in VB. The excited electron and positive hole reduce and oxidize substrates adsorbed on the surface, respectively. Using this so-called “band-structure model” in the scope of electrochemistry in which redox reactions, i.e., electron transfers, are regulated with electrode potential, CB electrons having relatively higher (more negative) potential can be transferred to redox species (A) of standard electrode potential (SEP) lower (more positive) than the CB-bottom potential and VB holes having

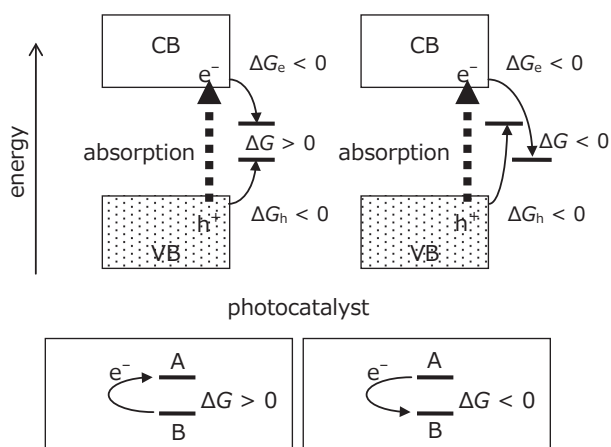

Figure 2. Energy diagram for photocatalytic and photoelectrochemical reaction by semiconducting materials with band-structure model. Even for the reactions with positive total Gibbs-energy change (ΔG), i.e., energy-storing reactions, if partial ΔG , ΔG_e and ΔG_h , for photoexcited electron and positive-hole transfer is negative, the reaction proceeds.⁵

relatively lower (more positive) potential can accept electrons from the other redox species (B) of SEP higher (more negative) than the VB-top potential. In this photoinduced redox reaction, an electron in B is formally transferred to A. In the case SEP(A) is more positive or negative than SEP(B), an electron in B loses or obtains electronic energy to result in negative or positive ΔG , respectively. Thus, electron and positive-hole transfer proceeds irrespective of overall ΔG of a reaction. This was not shown explicitly in the Fujishima's paper, but such interpretation has been spread especially in the field of electrochemistry, as many papers trying to reproduce the photoelectrochemical water splitting by electrochemists such as Wrighton⁶ and Nozik.⁷ Later, Bard proposed that heterogeneous photocatalysis by semiconductor particles can be explained by a model of a "short-circuited small photoelectrochemical cell" as an analog of ordinary (photo)electrochemical cell with two electrodes connected by an outer circuit.⁸

Thus, the Fujishima's paper had provided a new concept, interpreted by the band-structure model, of photoinduced redox reactions which are both applicable to positive and negative- ΔG reactions. This is the reason, at least the present author believes, why this Nature paper has given a strong impact and why heterogeneous photocatalysis and photoelectrochemical reactions have been accepted and understood by scientists even though at least a paper claiming the photocatalysis driven by bandgap excitation of titania particles had been published in 1971.⁹

3. Limitation of Band-structure Model for Describing Heterogeneous Photocatalysis

Reading carefully the very short paper (only one page in volume), it was reported that photoelectrochemical cleavage of water proceeded, i.e., photocurrent flew, only when electrochemical or chemical bias potential was applied to the photoirradiated single-crystal (rutile) titania electrode. Similarly, we have experienced frequently that no net water decomposition proceeds on a photocatalyst even though its CB bottom and VB top energies are measured/expected to be higher (more negative) and lower (more positive) than the hydrogen-evolution and oxygen-evolution SEP, respectively. For example, hydrogen and oxygen evolutions from commercial anatase-titania suspensions are observed when sacrificial electron donors and acceptors are added, respectively, suggesting sufficient energy of photoexcited electrons and positive holes,

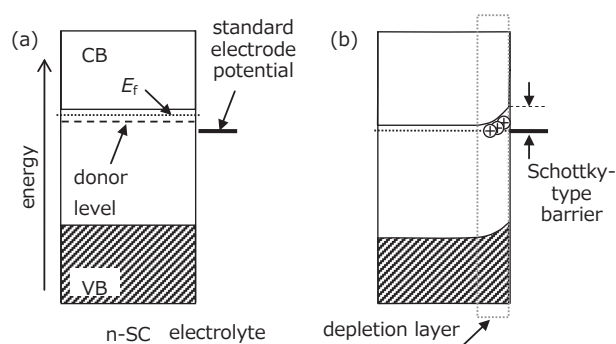

Figure 3. Schottky-type barrier created at the interface of n-type semiconductor (n-SC) with donor levels and electrolyte (a) before and (b) after their contact. Electric field is formed inside of the semiconductor electrode (material) and those part is called depletion layer where donor electrons are transferred to the electrolyte. For n-type semiconductor materials with low donor density, the depth of depletion layer must be larger than the size, i.e., such depletion layer cannot be presumed.⁴

though negligible water photolysis occurs in pure water. Such phenomena have so far been attributed to the recombination of electron-hole pairs without showing experimental evidence supporting this recombination. Thus, the above-mentioned band-structure model cannot give any information on the kinetics of photocatalytic reactions; it can be stated that we have discussed the mechanism and kinetics of heterogeneous photocatalysis without any appropriate models. Since redox reactions must proceed at the surface with surface-adsorbed substrates, surface structure as a channel of electron/positive hole flow must give influence on kinetics, but those surface structural properties cannot be described in the band-structure model.

Another limitation of the band-structure model is that the model is the same if the bulk structure, crystalline phase except for the cases of amorphous, i.e., non-crystalline materials, is the same. Therefore, it is impossible to explain the difference in photocatalytic activity of photocatalysts the crystalline phase of which are the same. This is because, again, the band-structure model does not contain any information of surface structure. The present author thinks that, due to such situation, nobody does not need to identify photocatalyst powders showing only their crystalline phase and, at most, particle size (or specific surface area). This problem will be discussed in Sections 8 and 9.

In the 1980's and early 1990's, it had been believed that band bending in a so-called space-charge (depletion) layer at the interface of n-type semiconductor materials and electrolyte promote the charge separation of photoexcited electron-positive hole pairs; electrons in donor levels in n-type semiconductors, having relatively high energy, flow out to electrolyte to result in formation of an electric field "inside" of the semiconductor materials.⁸ This seems to be influenced by surface/interface structure, but the band-bending concept is interpreted based on the assumption of homogeneously distributed donor levels (as "donor density") in the bulk of semiconducting materials, i.e., bulk structure. Considering the actual donor density in non-treated powder semiconductor materials such as titania, the expected depth of band bending was calculated to be even larger than the particle size, i.e., negligible slope inside of particles. Then, recent papers and reviews on semiconductor photocatalysis do not use the band-bending (space-charge layer) concept; the band structure is shown with horizontal linear lines.

4. Multielectron Transfer in Photocatalysis

Thus, in recent years, the simple band-structure model without

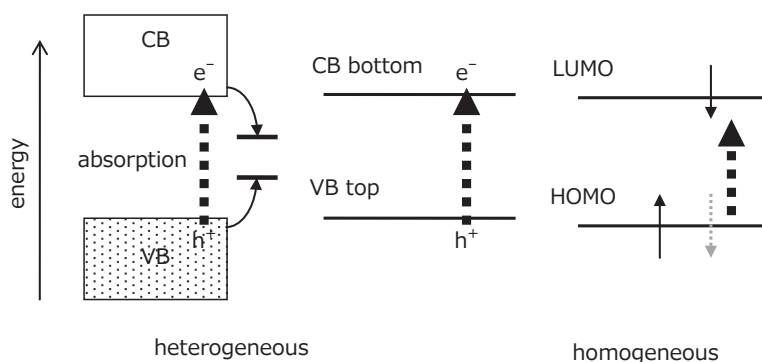
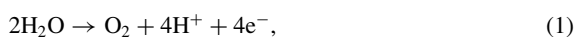

Figure 4. Energy diagram for heterogeneous (by semiconductor materials) and homogeneous (by molecules and metal complexes) photocatalysis.

space-charge layer has been used for interpretation for transfer of electrons and positive holes to surface-adsorbed substrates to be reduced and oxidized, respectively. As described in Section 2, thermodynamic requirement for those electron (hole) transfers is CB bottom and VB-top positions are higher (more negative) and lower (more positive), respectively, than the SEPs of corresponding redox couples. Although “band”-structure model is used, only CB bottom and VB-top levels, as linear lines, are considered, and this is not so different from the model drawn with LUMO (lowest unoccupied molecular orbital) and HOMO (highest occupied molecular orbital) for photoinduced redox reactions with molecules or metal complexes, in which only single-electron transfer, but not multi-electron transfer, is presumed. Thus, even though it is expected (and actually observed) that multielectron (positive hole) transfer reactions proceed in heterogeneous photocatalyses, the band-structure model does not provide any interpretation on the multielectron-transfer reactions.

As interpreted in Section 1, oxidation of water proceeds to liberate molecular oxygen (O_2) in photoelectrochemical cells and photocatalytic reaction systems. The reaction is expressed as,



and this half-cell four-electron reaction must be the largest-scale chemical reaction occurring on the earth as a part of photosynthesis by plants. Then the corresponding backward half-cell reaction, reduction of O_2 into water,

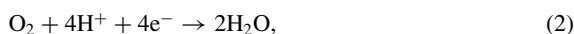

might proceed in the same scale by the activity of plants and animals to get energy by combustion of chemicals keeping the concentration of O_2 on the earth. Then the overall redox couple,



with SEP of 1.23 V (versus SHE = standard hydrogen electrode potential (0 V) in definition).¹⁰

In the history of photocatalysis (and photoelectrochemical) studies, in a sense surprisingly, the forward oxidation and backward reduction half cell reactions have been predominantly considered as, respectively, four electron (Eq. (1)) and one-electron processes,



and



but not four-electron process of Eq. (3). Although the present author does not know the reason, especially why one-electron process containing unstable radical species in the oxygen reduction is presumed, almost all the interpretations, within the author's knowledge, of oxygen reduction with photoexcited electrons as a

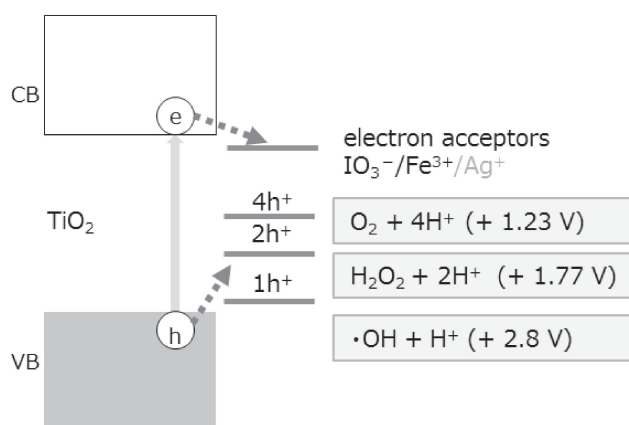

Figure 5. Standard electrode potential (SEP) for various redox couples related to water oxidation.

counter reaction of oxidation of organic/inorganic compounds by positive holes have been explained with one of these one-electron processes. A literature (or literatures) might suggest that superoxide anion radical, $O_2^{\bullet-}$, could be converted (degraded) into reactive oxygen species (often abbreviated as “ROS”), which work as oxidant for organic compounds, and this seems convenient to explain complete mineralization of organic compounds in photocatalysis under the aerobic conditions while direct conversion of oxygen into water (Eq. (2)) without releasing ROS could be inconvenient.

In a sense of electrochemistry, i.e., as thermodynamics of electrode reactions, such difference in the number of electrons included in redox couples is reflected in Gibbs-energy change (ΔG) of corresponding electrochemical equilibria such as Eqs. (3), (4) and (5); the higher the number is, the lower becomes ΔG , as the energy is calculated by dividing overall energy with the number. Therefore, SEP for four-electron water oxidation (Eq. (3)), 1.23 V, is lower (more positive) than those of one-electron and two electron water oxidation (Eqs. (6) and (7)), 2.8 V and 1.77 V, respectively.¹⁰



It should be noted that the further oxidation of those (intermediate) products of one electron and two-electron oxidation, hydroxyl radical (OH^{\bullet}) and hydrogen peroxide (H_2O_2), requires less energy, i.e., SEPs for those further oxidation are higher (more negative) than the original SEPs, and thus complete oxidation into oxygen occurs if the first step oxidation once proceeds not depending on the number of electrons in those equations. Then, what is the difference in the number of electrons? What is the meaning of the number?

Electrochemical equilibrium for SEPs is defined as a state where both anodic and cathodic current flows in equal (but reversed direction) quantity to result in no overall (net) current. The author's understanding is those electrochemical equilibria do not presume intermediate states. For example, for four-electron process (Eq. (3)) only the equilibrium of water and oxygen is considered without assuming intermediates such as $\text{OH}\cdot$ and H_2O_2 . In the other words, it should be assumed that at least four electrons go out and come in an electrode or an photocatalyst particle at the same time. This is reasonable since SEPs are thermodynamic parameter not kinetic parameter and thermodynamic parameters do not depend on reaction mechanisms and intermediates.

5. Limitation of Band-structure Model for Discussion Using Standard Electrode Potentials

Although it has not been clearly described in the discussion of SEPs, the meaning of "standard" is the activities (concentrations) of species appearing in the corresponding equilibrium are all unity and electrons (e^-) should also be in concentration of unity. For ordinary electrochemical systems using metal electrodes, this unity electron concentration is of definition and releasing and accepting multiple electrons from and to electrodes, respectively, can practically be guaranteed. Is this also the case for semiconductor electrodes and photocatalyst particles? For electrodes, it might be if sufficient number of positive holes (or electrons for reduction) are created under appreciably high intensity irradiation. However, for photocatalyst particles, it is questionable whether it stands.

The other problem lying in semiconductor electrochemistry, if the author does understand electrochemistry correctly, is there is no golden rule for which SEPs is adopted if given electrode potential is sufficient for multiple SEP processes, e.g., the VB-top position of titania is sufficiently lower (more anodic) than SEPs of one, two and four-electron oxidation of water, Eqs. (6), (7) and (3), respectively. One of the possible answers is that a process is chosen depending on activation energies of processes, i.e., a reaction process of the lowest activation energy proceeds predominantly, while the equilibria are thermodynamic neglecting the reaction pathway which governs the activation energy, i.e., there seems to be discrepancy in the activation energy-governing choice of transfer-electron number.

6. Number of Electrons in Photocatalytic Oxygen Evolution

Based on the previous studies¹¹ on light-intensity dependence (LID) of photocatalytic-reaction rate for oxidation of acetic acid under aerobic conditions and methanol dehydrogenation with in-situ deposited platinum under deaerated conditions, a group of the present author has been studying LID of titania-photocatalyzed oxygen evolution, as one of the representative multielectron transfer process, from suspensions containing electron acceptors using highly intense UV-LEDs (365 nm, maximally ca. 2.5 W cm^{-2}) to obtain suggestion for number of transferred electrons.¹³

All the examined titania samples showed linear oxygen evolution without appreciable induction period. Among examined four commercial titania samples (nanometer sized small and a few hundred nanometer-sized large anatase and rutile), small anatase and rutile showed second and first-order LIDs in the relatively low and middle light-intensity ranges, respectively, while large anatase and rutile samples showed only first-order dependence in the whole light-intensity range. The bimodal LID for small titania particles was observed not depending on the kind of electron acceptors, iodate (IO_3^-) and iron(III) (Fe^{3+}) ions. A kinetic model based on the assumption that two-electron oxidation of water to hydrogen peroxide proceeds only when two positive holes are accumulated in one titania photocatalyst particle, but one positive hole-bearing particles cannot drive one-electron oxidation, reasonably interpret

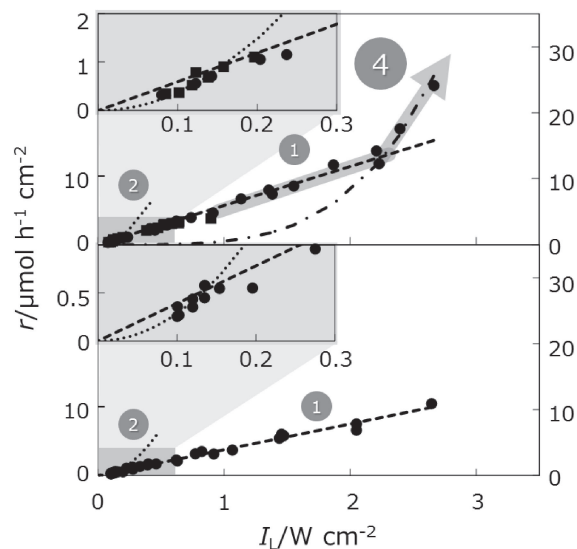

Figure 6. Light-intensity (I_L) dependence (LID) of the rate of photocatalytic oxygen evolution (r) by (upper) small anatase (8 nm) and (lower) small rutile (13 nm) particles suspended in deaerated aqueous electron acceptor solutions. Bimodal, second and then first-order, LID was observed for both titania samples, while large anatase and rutile samples exhibit first-order LID in whole intensity region.¹³

the bimodal LID. At the relatively low intensity region, the probability of accumulation of two positive holes in one particle is proportional to square of light intensity and increase in the light intensity to the middle intensity region particles tend to have two positive holes by absorbing the second photon within the lifetime of first positive hole created by the first photon, i.e., accumulation of two positive holes in each particle is guaranteed to result in the first-order LID. This suggests that under the ordinary photoirradiation conditions using continuous light sources titania choose two-electron process for water oxidation, even though four-electron process is much easier than the two-electron process. Thus, the number of possible accumulation of positive holes in each photocatalyst particle governs photocatalytic-reaction kinetics and the kinetics depends on the size of photocatalyst particles as photon absorber; the large anatase and rutile particles showed only first-order LID as two positive-hole accumulation is guaranteed for those large titania particle even at the lower intensity region.

A significant finding was that almost fourth-order LID was observed when the small-anatase suspension was irradiated at the highest intensity $> 2 \text{ mW cm}^{-2}$.¹³ This is the first example of such high-order dependence of reaction rates within the author's knowledge. What should be noted is that this fourth-order LID appeared suddenly at a "singularity" point, which is unusual in chemistry. Assuming that four-electron process proceeds at this higher light-intensity region and the probability of accumulation of four positive holes in each particle is increased, in fourth order, with light intensity, i.e., four positive-hole accumulation is not guaranteed in this light intensity region, the particles choose four-electron process even though two-electron process is guaranteed and actually proceeds. In the other words, kinetics of oxygen evolution is governed digitally by the number of transferred electrons, and this unusual kinetics, again, cannot be interpreted by the band-structure model.

7. Number of Electrons of Oxygen Reduction in Photocatalytic Oxidation of Organic Compounds

The reversed process of oxygen evolution, oxygen reduction, was

also studied by the above-mentioned LID analysis using highly intense UV-LEDs and the results seemed not to be interpreted with the band-structure model.

It has been believed that oxygen reduction by photoexcited electron(s) as a counter reaction of oxidation of organic/inorganic compounds by positive holes in photocatalysis proceeds through one-electron transfer (Eqs. (4) and (5)). Often observed lower or negligible activity of rutile titania samples for the mineralization of organic compounds is attributed to the lower CB-bottom energy, ca. 0.2-eV lower than that of anatase,¹⁴ not sufficient for the one-electron reduction of oxygen.^{15,16} Tungsten(VI) oxide (WO_3), absorbing visible light, is also recognized to be inactive due to its lower CB-bottom energy, while loading of platinum deposits on the surface enhanced the photocatalytic activity, comparable or even higher than that of anatase samples, by promoting two (or four)-electron reduction on the platinum surface.^{17,18}

Bismuth tungstate (Bi_2WO_6 ; BWO) has been reported to be an active photocatalyst driving photocatalytic mineralization of organic compounds even though BWO has relatively smaller bandgap leading to visible-light absorption like WO_3 . The author's group has reported the hydrothermal synthesis of hierarchically structured BWO, flake-ball particles, which exhibit high-level photocatalytic activity for organics mineralization.^{19–24} It has been believed that CB-bottom position is higher (more negative) than SEPs for one-electron reduction of oxygen and relatively narrower bandgap is presumably attributable to upward (cathodic) shift of VB-top position by overlapping bismuth-originated orbitals. However, recent studies^{25,26} suggested that CB-bottom position is lower than the one electron-reduction SEPs on the basis of the fact that BWO cannot induce photocatalytic hydrogen evolution from deaerated aqueous methanol even with loaded platinum deposits and the corresponding SEP, standard hydrogen-electrode potential (SHE) is lower than the one electron-reduction SEPs. Therefore, two-electron reduction of oxygen by BWO was suggested.

LIDs in photocatalytic acetic-acid decomposition in aerobic aqueous BWO suspensions were bimodal, first and 0.5th orders at relatively lower and middle light-intensity region, respectively, in principle. Since peroxy radical-mediated radical-chain mechanism has been proposed to be involved in photocatalytic organics-oxidation mechanism and this leads square-root (0.5th) dependence,^{11,12} second and then first-order bimodal LID for accumulation of photoexcited electrons in each photocatalyst particle may result in the observed first and then 0.5th-order LID.²⁷ This seems consistent with the above-mentioned CB-bottom position of BWO lower than the one-electron oxygen reduction SEPs.

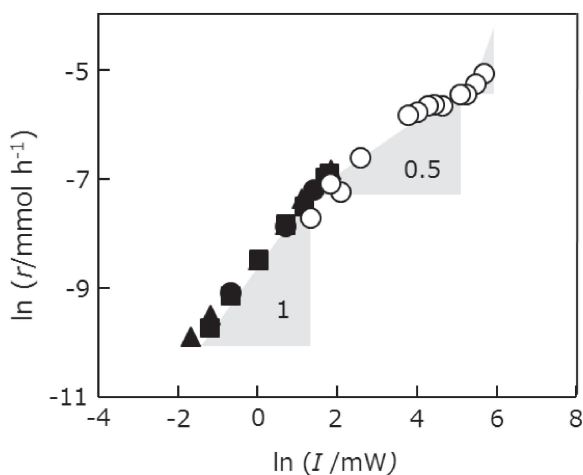

Figure 7. Light-intensity dependence (LID) of the rate (r) of photocatalytic decomposition of acetic acid by BWO under aerobic conditions. Bimodal, first and then 0.5th, LID was observed.²⁷

Although the above-mentioned story of oxygen-reduction mechanism can be interpreted using band-structure model in relation to the corresponding oxygen-reduction SEPs, there are still at least two unsolved problems. One is why BWO can drive the two-electron oxygen reduction while WO_3 cannot in the absence of loaded platinum deposits. Thermodynamics predicted by the similar CB-bottom positions of BWO and WO_3 does not give the answer, while the LID-based kinetic analyses could suggest which SEP, one-electron or two-electron transfer, is chosen by a given photocatalyst. Another unsolved problem is effect of particle size in multielectron-transfer photocatalyses. The results of both oxygen evolution and oxygen reduction have shown particle-size dependent LIDs and suggested the requirement of “effective particle size” concept by which unit size capable of accumulation of multiple electrons (or positive holes) is defined.^{13,27} Further LID analyses for platinum-loaded WO_3 ²⁸ and titania photocatalysts are now in progress.

8. Identification of Metal-oxide Photocatalyst Materials

In the field of organic chemistry, identification of target compounds is essential; no papers are accepted unless all the chemicals used in the study are adequately identified; it is well-known and accepted that at least elemental-analytical data with less than 0.3%-error compared to the calculated value and nuclear magnetic resonance (NMR) data are shown for identification of a target compound. However, in the field of material/inorganic chemistry, not limited to that of heterogeneous photocatalysis, no attempts, as far as the present author knows, have been made to identify the target solid compounds which are used as solid not as their solutions. This is not strange as it is described in a book of nomenclature of inorganic compounds²⁹ that “in cases where detailed structural information is to be conveyed, fully systematic names can be difficult to construct”, i.e., we have to give up to put name to solid inorganic compounds reflecting their structure according to this IUPAC (International Union of Pure and Applied Chemistry) recommendation. It should be noted that we have been discussing performance, activity or properties of solid materials, not limited to solid photocatalysts, without identification.

What does prohibit us to identify inorganic solid material? This is simply because those solids have surfaces with their structure and thereby we need to identify the surface structure (structures). However, as is easily expected, surface structure, i.e., arrangement of atoms/ions cannot be systematically described as is for crystal structure and the structure may not be uniform. There have been used many analytical methods for solid-surface structures in microscopic ways, e.g., scanning probe microscopy and transmission electron microscopy. Those microscopic techniques enable atomic-scale analysis of surface structures, but those are just analyses of what can be analyzed, and there is no guarantee for that what is measured is predominant for the whole sample. In this sense, macroscopic, not microscopic, analytical methods are required for “solid-sample identification”, though there have been few methods to analyze solid-surface structure in macroscopic ways; temperature programmed adsorption/desorption analyses and zeta-potential analysis are macroscopic, but they seem not comprehensive for metal-oxide samples and a wide range of solid materials.

Previously, more than 30-years ago, infrared (IR) spectra had been used as fingerprints for organic compounds, since patterns in a certain wavenumber range are practically different for compounds with different structure, and there had been published many books compiling IR spectra of organic compounds. It is expected, therefore, that if patterns/spectra reflecting the surface structure of solid samples are obtained, they can be used as fingerprints for identification. An important point is that those patterns/spectra need not to be fully interpreted how the actual surface structure is reflected in them.

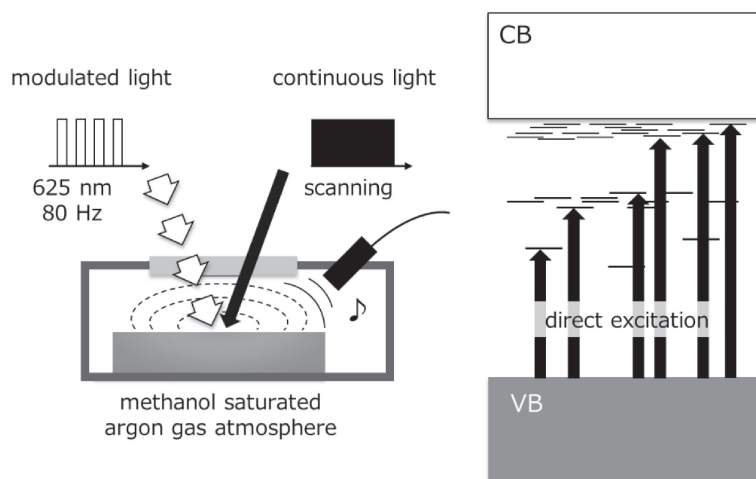

Figure 8. Schematic representation of reversed double-beam photoacoustic spectroscopy (RDB-PAS).³⁰

9. Energy-resolved Distribution of Electron Traps as a Fingerprint for Identification

Recently, the author's group have developed a novel analytical method, reversed double-beam photoacoustic spectroscopy (RDB-PAS), enabling measurement of energy-resolved distribution of electron traps (ERDT) in metal-oxide samples.^{30,31} Here, "electron trap (ET)" is defined as an electronic level which can store an electron. ERDT patterns for few commercial titania powder sample had been measured by chemical titration of fully ET filled-sample suspensions.³² The principle of the RDB-PAS measurement is described as: (1) electrons in the valence band are directly excited to electron traps from a deeper level to a shallower level by wavelength-scanned continuous light, (2) photoabsorption of accumulated electrons is detected by wavelength-fixed modulated light through photoacoustic detection, (3) the thus-obtained accumulation curve is differentiated from longer-wavelength (lower energy) side to obtain an ERDT pattern and (4) the density is calibrated with the reported electron-trap (ET) density (with the above-mentioned chemical titration³²). In all the measured commercial titania samples, ETs were distributed mainly below the conduction band-bottom (CBB) positions. The total ET density was increased with increasing specific surface area suggesting that ETs are located mainly on the surface and ERDT reflects the surface structure of samples.

It has been shown that patterns of ERDT combined with the CB-bottom (CBB) position (ERDT/CBB patterns) can be used as a fingerprint of metal-oxide powders for their identification; anatase (or rutile) titania powders, which are not differentiated in the band-structure model, showed the patterns different with each other. To evaluate identicalness, similarity or differentness for a pair of samples quantitatively, a novel parameter, degree of coincidence, ζ , of ERDT/CBB patterns has been introduced by checking (multiplying) three kinds of degree of coincidence in (a) ERDT pattern shape, (b) total ET density and (c) CBB position (energy).^{30,31} For three titania powder samples carefully taken from almost the same position in the same bottle, ζ values of pairs of three samples were ca. 0.9 suggesting that it is possible to say a given pair of samples "identical" if ζ is higher than 0.9.

For the pairs of commercial titania samples, degree of coincidence of activities (ζ_{pc}) for three kinds of photocatalytic reactions, methanol dehydrogenation under deaerated conditions with in situ-deposited platinum, acetic-acid decomposition under aerobic conditions and oxygen evolution from deaerated silver salt suspensions, were measured and plotted as a function of ζ . The plot

was rather scattered, but a modified plot taking seven-point moving average clearly showed that the higher the ζ is, the higher becomes ζ_{pc} at ζ higher than 0.6, i.e., for the pairs of samples with ζ below 0.6, the activity ratio was accidentally high or low, while for the pairs of samples with ζ above 0.6, similar pairs exhibited similar photocatalytic activity. Though this seems to be natural consequence, this clearly shows that the evaluation of identicalness, similarity or differentness using ERDT/CBB patterns is appropriate presumably due to the fact that three points for ζ evaluation, ERDT pattern, total ET density and CBB position reflect (cover) macroscopic surface structure, surface (bulk) size and bulk structure, respectively, and thus sample structure is totally evaluated.

10. Photocatalytic Activity-structure Correlation

As has been discussed in Sections 2 and 3, band-structure model gives information on thermodynamics while kinetics, e.g., photocatalytic activity of samples, cannot be interpreted using the band-structure model; it is clear from, e.g., the results shown in Sections 7 and 9, that photocatalytic activity of titania samples cannot be explained only by crystalline form of titania, anatase or rutile. Then, specific surface area, particle size or crystalline-defect density have been employed to interpret the possible difference in photocatalytic activity of samples.^{2,4} There are at least two problems. One is that those properties are changed (modified) simultaneously and thereby it is difficult or logically impossible to specify or extract the influence of a given property on activity. One of the possible solutions is to use statistical analysis enabling analysis of contribution of physical/structural properties on photocatalytic activities.^{15,16} The other problem is that physical/structural properties used in the structure activity-correlation analyses have been limited to properties of bulk, not surface of photocatalyst samples (Specific "surface" area only shows the size of surface (or bulk) not depending on the surface structure.). On the other hand, as described in Section 9, ERDT/CBB patterns reflect both bulk and surface properties of metal-oxide samples and can be used in structural property activity-correlation analyses, though the relation between actual (surface) structure and ERDT patterns is still unknown.

As reported recently,³³ correlation between structural property and photocatalytic activity of titania samples was analyzed using their ERDT/CBB patterns; the patterns were arranged in the order of photocatalytic activity of the representative three kinds of reactions (See Section 9.). Except for the methanol dehydrogenation, a two-step reaction (photodeposition of platinum and hydrogen evolution by platinum-deposited particles), ERDT patterns of the highest

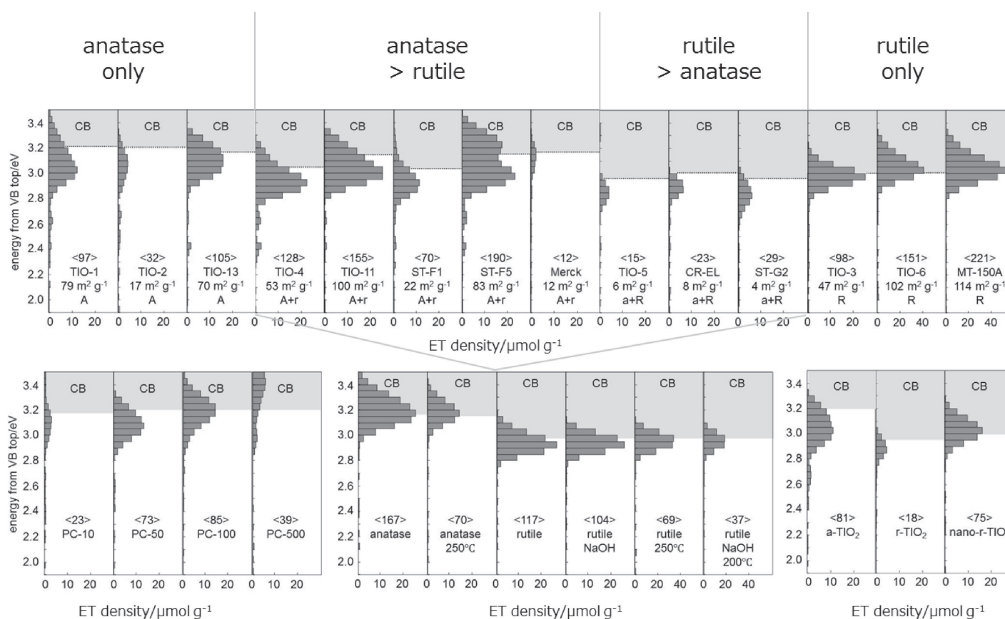

Figure 9. Representative energy-resolved distribution of electron traps (ERDT)-conduction band-bottom position (CBB) patterns of commercial titania samples. Figures in $\langle \rangle$ show total density of electron traps (ETs).³¹

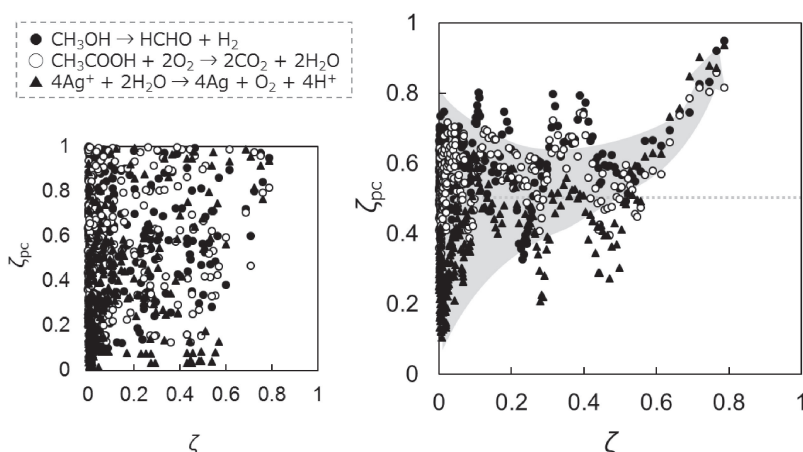

Figure 10. (Left) Plot of degree of coincidence of photocatalytic activities (ζ_{pc}) in three representative systems against degree of coincidence (ζ) of pairs of commercial titania samples and (right) similar plots using seven-point non-weighted moving average of ζ_{pc} .^{31,33}

activity group were all alike, but those of the middle and lower activity group showed no clear similarity with each other. One of the explanation for this is that all the structural properties affecting activity of the highest activity-group samples are optimized to result in the resemblance of ERDT/CBB patterns, while each less-active sample is inactive as one (or some) of the properties is (are) not optimized. This seems consistent with the results of statistical analysis, which suggested that photocatalytic activities are not always governed by one property. Again, it can be said that photocatalytic activities cannot be interpreted by the band-structure model.

11. Conclusive Remarks–To Go Beyond

More than 40 years passed after the publication of the first paper on photoelectrochemical splitting of water, which practically initiate the studies on heterogeneous photocatalysis. Since then a lot of papers have been published and number of researchers in field has been increasing. However, the present author has to confess that still fundamental understandings, e.g., so-called structure-activity corre-

lation, are left unclarified. One of the reasons is the researchers in field, of course including the present author, insist to explain the results only by using the band-structure model. The author believes that breakthrough must be achieved by going beyond the band-structure model and hopes this review promote this.

Acknowledgments

The author thanks all the collaborators and supporters. Without their enthusiastic works and supports, it was really impossible to find the above-mentioned hints to go beyond the band-structure model. Some of studies presented in this paper were financially supported by Grant-in-Aid (KAKENHI) from the Ministry of Education, Culture, Sports, Science and Technology (MEXT) of Japan and Japan Society for the Promotion of Science (JSPS).

References

1. A. Fujishima and K. Honda, *Nature*, **238**, 37 (1972).
2. B. Ohtani, *Chem. Lett.*, **37**, 217 (2008).

3. B. Ohtani, *Electrochemistry*, **82**, 414 (2014).
4. B. Ohtani, *J. Photochem. Photobiol. C*, **11**, 157 (2010).
5. B. Ohtani, *Phys. Chem. Chem. Phys.*, **16**, 1788 (2014).
6. M. S. Wrighton, D. S. Ginley, P. T. Wolczanski, A. B. Ellis, D. L. Morse, and A. Linz, *Proc. Natl. Acad. Sci. U.S.A.*, **72**, 1518 (1975).
7. A. Nozik, *Nature*, **257**, 383 (1975).
8. A. J. Bard, *J. Phys. Chem.*, **86**, 172 (1982).
9. M. Formentí, F. Juillet, P. Meriaudeau, and S. J. Teichner, *Chem. Tech.*, **1**, 680 (1971).
10. A. J. Bard, R. Parsons, and J. Jordan, *Standard Potentials in Aqueous Solution*, Marcel Dekker, New York and Basel (1985).
11. T. Torimoto, Y. Aburakawa, Y. Kawahara, S. Ikeda, and B. Ohtani, *Chem. Phys. Lett.*, **392**, 220 (2004).
12. S. Kato and F. Masuo, *Kogyo Kagaku Zasshi*, **67**, 42 (1964).
13. S. Takeuchi, M. Takashima, M. Takase, and B. Ohtani, *Chem. Lett.*, **47**, 373 (2018).
14. L. Kavan, M. Grätzel, S. E. Gilbert, C. Klemenz, and H. J. Scheel, *J. Am. Chem. Soc.*, **118**, 6716 (1996).
15. O.-O. Prieto-Mahaney, N. Murakami, R. Abe, and B. Ohtani, *Chem. Lett.*, **38**, 238 (2009).
16. B. Ohtani, O.-O. Prieto-Mahaney, F. Amano, N. Murakami, and R. Abe, *J. Adv. Oxidat. Tech.*, **13**, 247 (2010).
17. R. Abe, H. Takami, N. Murakami, and B. Ohtani, *J. Am. Chem. Soc.*, **130**, 7780 (2008).
18. O. Tomita, B. Ohtani, and R. Abe, *Catal. Sci. Technol.*, **4**, 3850 (2014).
19. F. Amano, K. Nogami, R. Abe, and B. Ohtani, *Chem. Lett.*, **36**, 1314 (2007).
20. F. Amano, K. Nogami, R. Abe, and B. Ohtani, *J. Phys. Chem. C*, **112**, 9320 (2008).
21. F. Amano, K. Nogami, and B. Ohtani, *J. Phys. Chem. C*, **113**, 1536 (2009).
22. F. Amano, K. Nogami, and B. Ohtani, *Langmuir*, **26**, 7174 (2010).
23. H. Hori, M. Takase, F. Amano, and B. Ohtani, *Chem. Lett.*, **44**, 1723 (2015).
24. H. Hori, M. Takase, M. Takashima, F. Amano, T. Shibayama, and B. Ohtani, *Catal. Today*, **300**, 99 (2018).
25. H. Hori, M. Takashima, M. Takase, and B. Ohtani, *Chem. Lett.*, **46**, 1376 (2017).
26. H. Hori, M. Takashima, M. Takase, M. Kitamura, F. Amano, and B. Ohtani, *Catal. Today*, **303**, 341 (2018).
27. H. Hori, M. Takashima, M. Takase, and B. Ohtani, *Catal. Today*, **313**, 218 (2018).
28. C. Yamada, M. Takashima, and B. Ohtani, *Pre-conference of TOCAT8 and the 5th International Symposium of Institute for Catalysis–Material Design for Efficient Catalysis and Sustainable Chemistry–*, Sapporo, P-46 (2018).
29. *Nomenclature of Inorganic Chemistry, IUPAC Recommendations 2005*, The Royal Society of Chemistry, p. 236 (2005).
30. A. Nitta, M. Takase, M. Takashima, N. Murakami, and B. Ohtani, *Chem. Commun.*, **52**, 12096 (2016).
31. A. Nitta, M. Takashima, N. Murakami, M. Takase, and B. Ohtani, *Electrochim. Acta*, **264**, 83 (2018).
32. S. Ikeda, N. Sugiyama, S.-y. Murakami, H. Kominami, Y. Kera, H. Noguchi, K. Uosaki, T. Torimoto, and B. Ohtani, *Phys. Chem. Chem. Phys.*, **5**, 778 (2003).
33. A. Nitta, M. Takashima, M. Takase, and B. Ohtani, *Catal. Today*, in press.