

# Ultraviolet Photoelectron Spectroscopy (UPS)

- Similar to XPS
- Photon Energy Range
  - VUV – “Vacuum Ultraviolet”
  - Typically 10eV-100eV
- Probes valence states, not core levels
  - Valence states are responsible for
    - crystal/molecular bonding
    - charge transport
- Much higher energy resolution possible
  - A few meV vs  $\sim 1$ eV
- Higher surface sensitivity than XPS

# Methods of Producing VUV Photons

- Synchrotron Radiation
  - Canadian Light Source, Berkeley ALS, etc
  - Bremsstrahlung radiation created by bending magnets, wigglers, undulators, etc
  - Pros:
    - Very high photon flux
    - Continuously tunable photon energy throughout VUV
  - Cons:
    - Very expensive to build a facility - \$200 million
    - Must travel to a synchrotron lab
    - Many things can go wrong with your experiment while at the lab, resulting in wasted trips to the synchrotron!
    - Can be very frustrating

# Methods of Producing VUV Photons

- Gas discharge lamp
  - VUV photons are emitted by gas plasmas
  - Plasma is most easily generated at  $\sim 1$  Torr
  - How do we get the photons into our UHV chamber?
    - Problem: No materials are transparent to these photons:
      - We can't make a VUV window
  - Differentially pumped discharge lamps



# Differentially Pumped Discharge Lamp

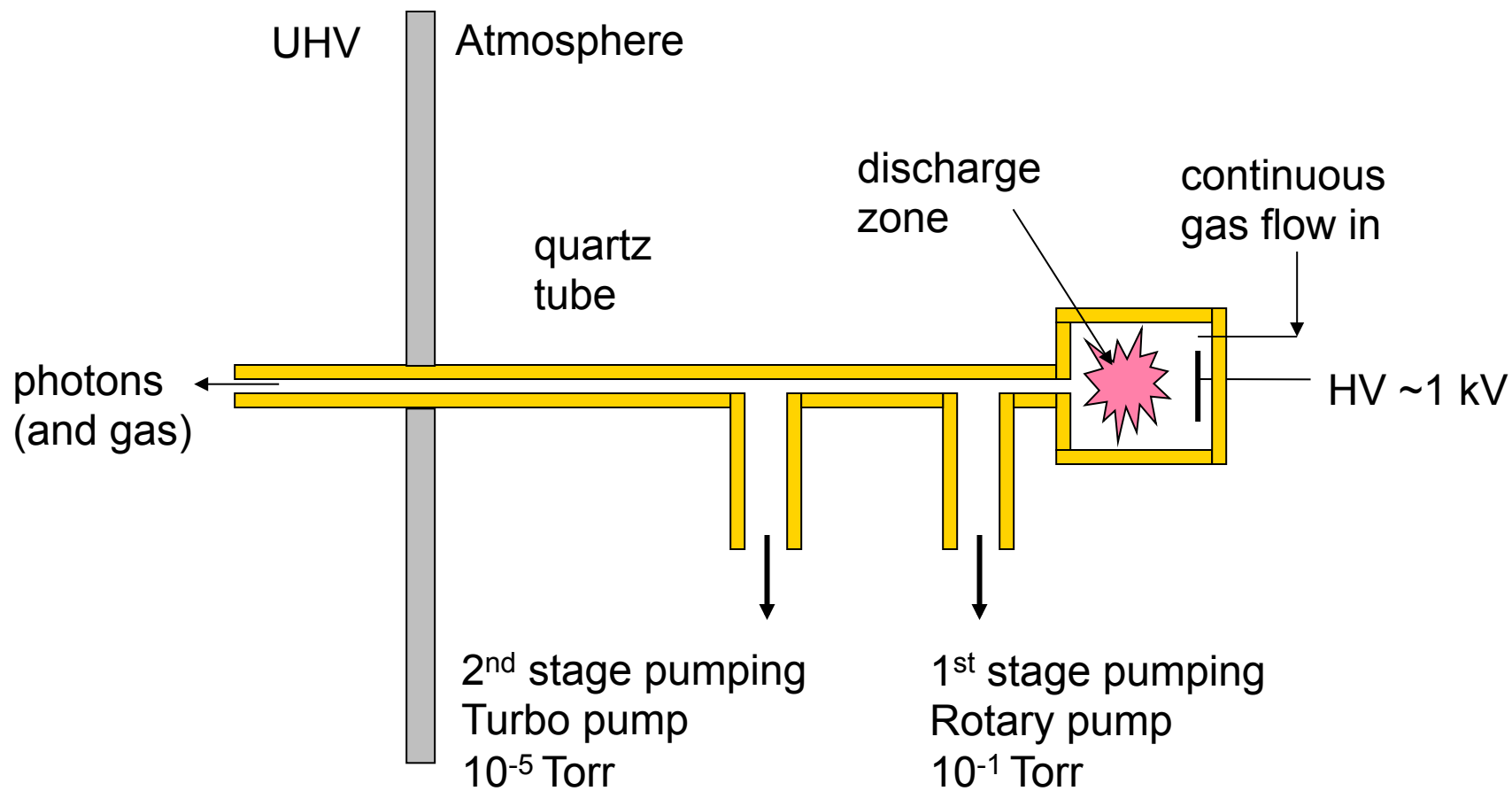

# Differentially Pumped Discharge Lamp

- We can never completely remove the gas through the differential pumping stages
- Problem: **Our sample must be maintained in UHV or it will be contaminated**
- Only noble gasses are used in a differentially pumped lamp
- Inert gasses will not react with our sample
- He, Ne, Ar, Xe
- Most commonly used: He
  - Characteristic emission lines:
    - He I (21.2 eV)
    - He II (40.8 eV)

# Differentially Pumped Discharge Lamp

- Recall: While operating a differentially pumped discharge lamp, inert gas is continuously flowing into the analysis chamber.
- Where does it go?
  - Analysis chamber vacuum is typically maintained by an ion pump
  - Ion pumps remove gas by chemically binding gas atoms/molecules to Ti
  - **Ion pumps cannot pump inert gasses!**
- A large turbomolecular pump must be added to the analysis chamber during UPS to remove the inert gas

# Differentially Pumped Discharge Lamp

- Pros:
  - Less expensive than a synchrotron: 40k vs 200M
  - Can be housed in a small university lab
  - Available for use every day
- Cons:
  - Photon energy not tunable
    - Limited to atomic emission lines
  - Intensity cannot be easily tuned
  - Many emission lines have fine structure (doublets, etc)

# Valence vs Core levels

- For a given element, the core levels “look” largely the same, regardless of the solid of which they are constituents
  - Core level shifts, depending on chemical environment
  - Final state effects: shake-up, shake-off, asymmetric broadening
- Valence states, however, hybridize with those of neighbouring atoms due to wave function overlap
  - New, localized hybrid orbitals, or
  - Delocalized bands → crystal band structure



# Valence vs Core Levels

- Identification of atomic core levels is (usually) clear
- Valence states, however, are more difficult to identify, due to hybridization
  - A hybridized orbital is, by definition, a combination of orbitals of different atoms, not necessarily of the same species
  - Large energy shifts occur due to hybridization, so binding energy cannot unambiguously identify a spectral feature
  - Delocalized energy bands disperse with momentum.
    - Binding energy depends on the momentum of the state (more on this later)
    - Bandwidths vary (near zero to 10 eV or more)
  - Detailed analysis of valence spectra typically require theoretical modeling of the material being studied

# Energy Resolution

- On the detection side, the energy resolution is determined by the radius of the hemispherical energy analyzer, its acceptance angle (slit width), and pass energy
- From this perspective, the resolution of UPS and XPS should be comparable if operated with the same parameters

# Pass Energy and Slit Width Determine

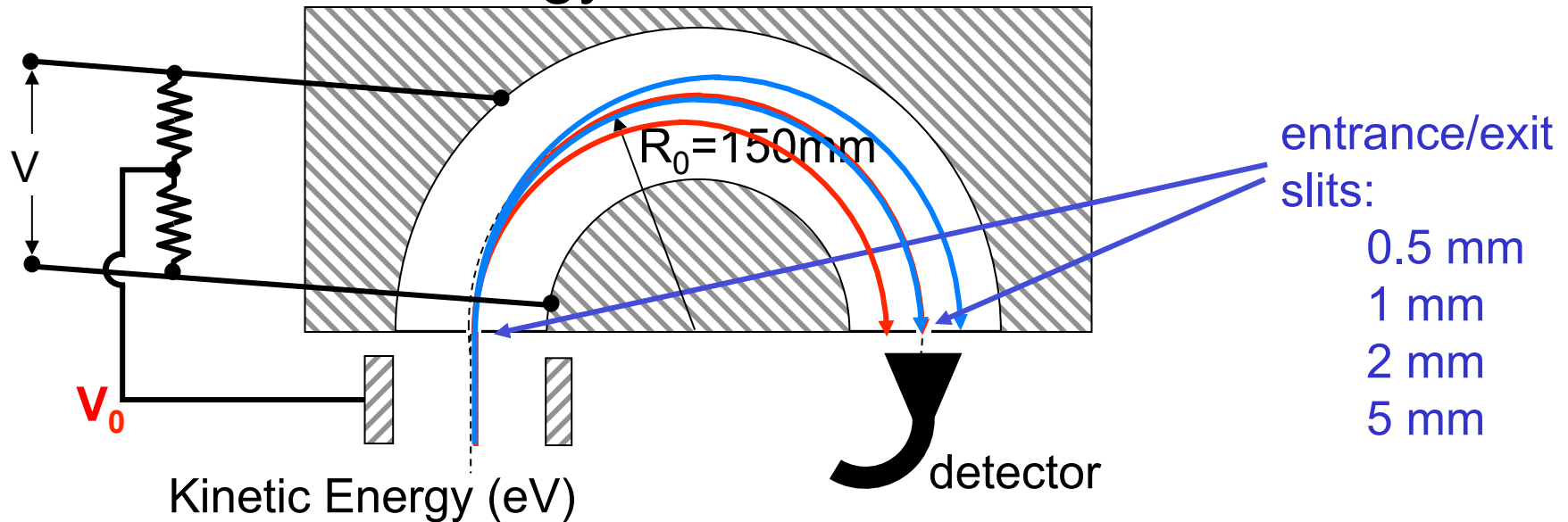

Pass Energy  $E_p = eV_0$

Resolution  $\Delta E$ :

$$\Delta E \cong E_p \left( \frac{w}{2R_0} \right)$$

For 5mm slit, the analyzer resolution is  $\sim 1.5\%$  of pass energy

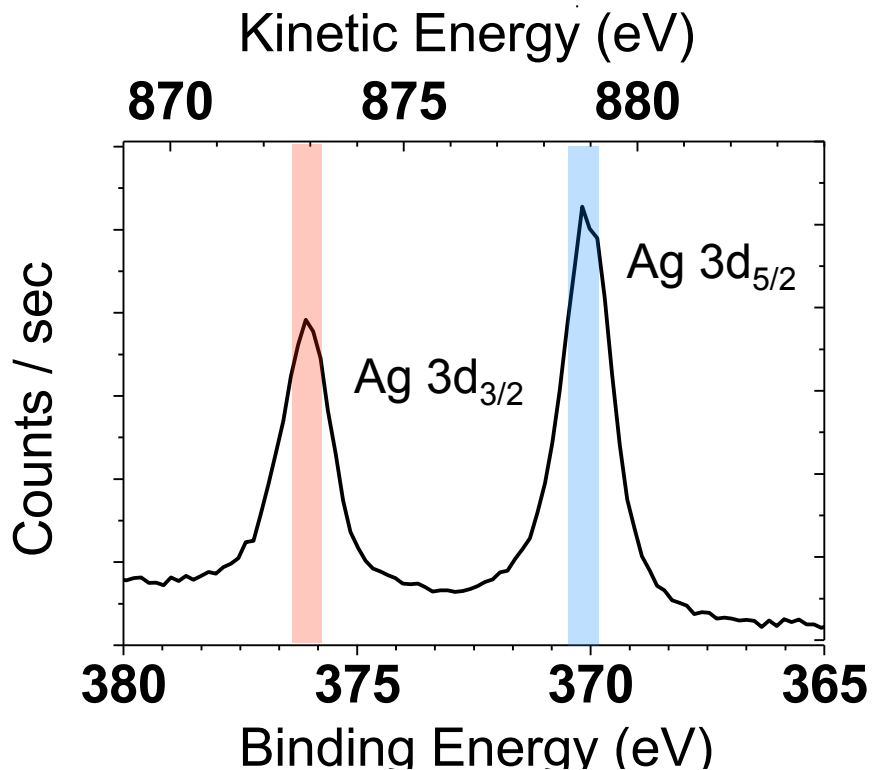

# Energy Resolution

- For a 150mm hemispherical analyzer with 0.5 mm slits and a 5 eV pass energy, 8 meV should be possible
- We never achieve this resolution in XPS. Why?
  - Excitation source linewidth: for a simple Al K $\alpha$  x-ray source, ( $h\nu = 1486.6$  eV) the line width is around 0.75 eV
  - Core hole lifetime broadening. The lifetime of the empty core hole state is very short. By Heisenberg's uncertainty principle, this means that the binding energy of the state can not be measured with arbitrary precision:

$$\Delta E \geq \frac{\hbar}{2\Delta t} \quad \text{where } \Delta t \text{ is the lifetime of the core hole}$$

- Valence hole states are much longer lived than core states
- VUV sources can have much narrower line widths

# How do we determine our resolution?

- We measure the width of a spectral feature which has a natural linewidth which is  $\ll$  than our instrumental resolution
- Gas phase UPS of inert gas
- Fermi edge of a metal

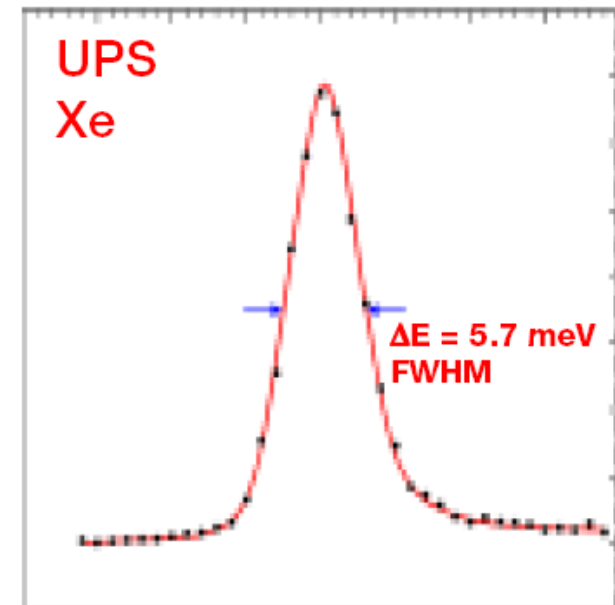
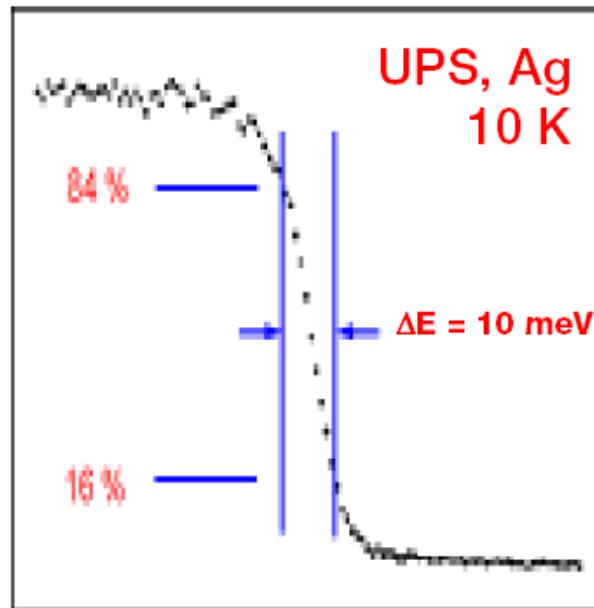

# Notes on Deriving Resolution from the Fermi Edge

- 1) We are assuming the density of states is almost constant around  $E_F$
- 2) We assume that the Fermi-Dirac function is approximately a step function, so the spectrum is just a Gaussian convolved with a step (note: this is just the integral of a Gaussian)
- 3) In reality, the Fermi-Dirac “step” is about  $3.3 kT$  wide (83 meV at RT)
- 4) If our resolution is better than this, we must go to low temperature

$$FD(E) = \frac{1}{1 + e^{\frac{E-E_F}{kT}}}$$

$$E - E_F = kT \times \ln\left(\frac{1}{FD(E)} - 1\right)$$

$$\text{for } FD(E) = 0.84,$$

$$E - E_F = -1.66kT$$

$$\text{for } FD(E) = 0.16,$$

$$E - E_F = +1.66kT$$

# How do we determine our resolution?

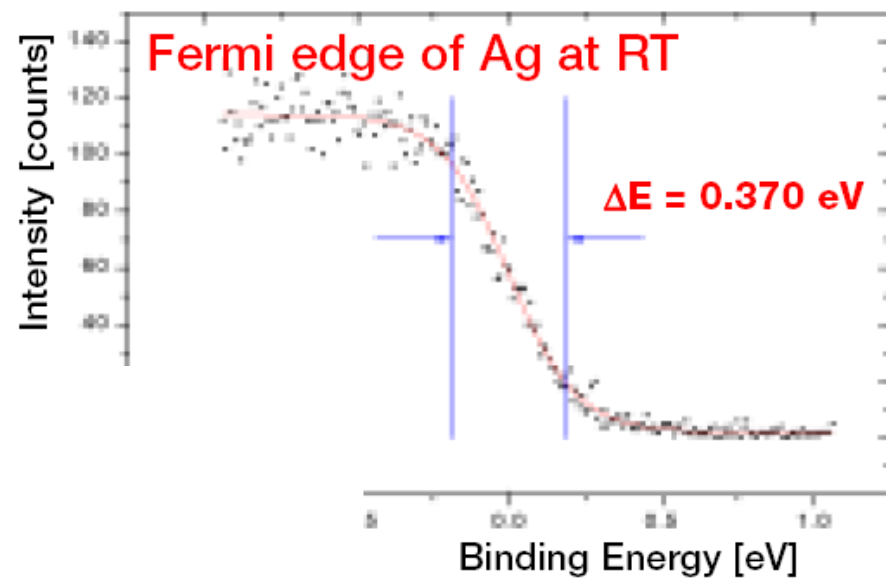

# High Surface Sensitivity of UPS

“universal escape depth curve”

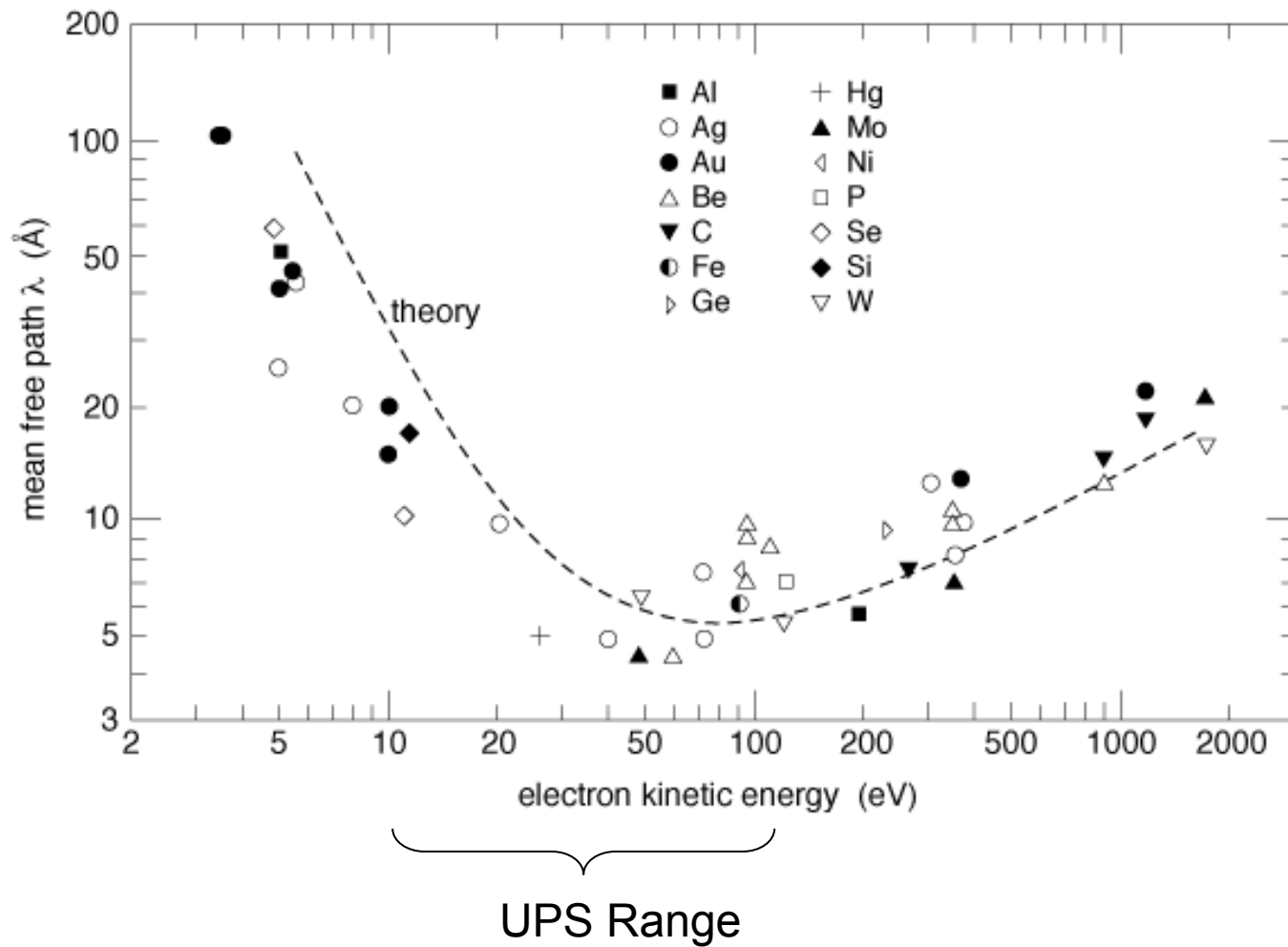



# High Surface Sensitivity of UPS

- Pros

- High sensitivity to surface species
- Study catalysis
- Study adsorbed (sub) monolayers
- Study surface reconstructions

- Cons

- Not a good bulk probe
- Results are *very* sensitive to surface contamination
- Surface properties can be very different than bulk. Care must be taken when generalizing UPS to bulk

# Density of Valence States via UPS

- Kinetic energy of electron just outside the sample is given by the photon energy minus the binding energy (relative to the vacuum) of the initial state
- Kinetic energy is further modified by the contact potential (difference in work functions) between the sample and the analyzer
- The kinetic energy measured at the analyzer is  $E_{ka} = E_{ks} + (\phi_s - \phi_a)$

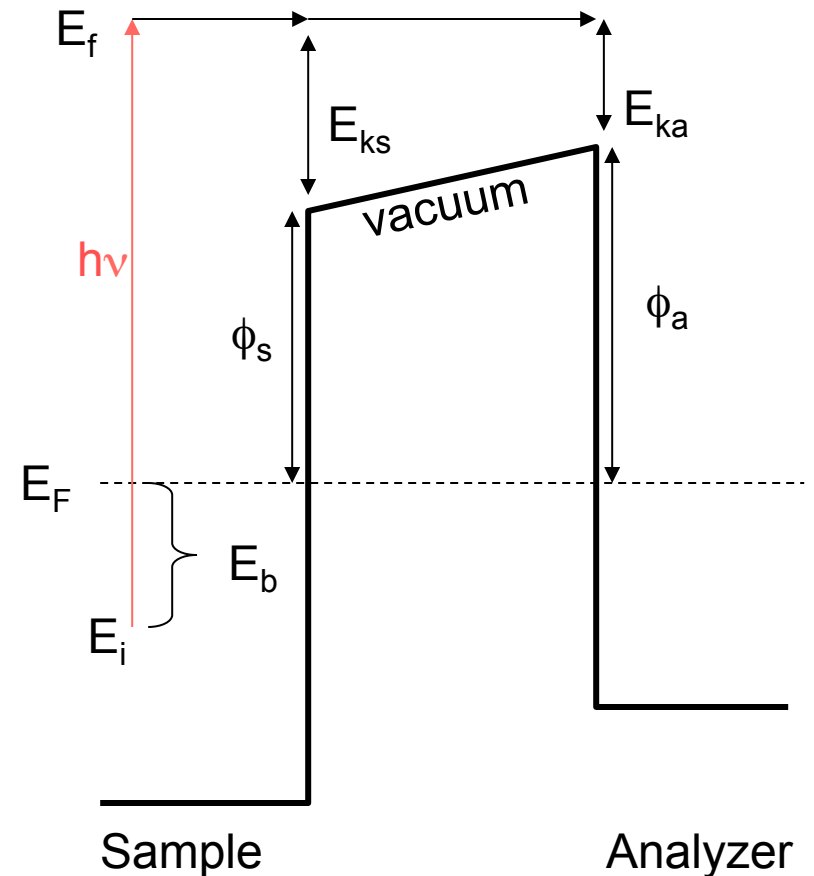

Binding energy of  $E_i$  with respect to the Fermi Energy is given by:  $E_b = h\nu - (E_{ka} + \phi_a)$

# Example: Organics on Metals

- Growth of molecular layers and metal deposition in UHV ( $10^{-10}$  Torr)
- Incremental build-up of interface + photoemission spectroscopy

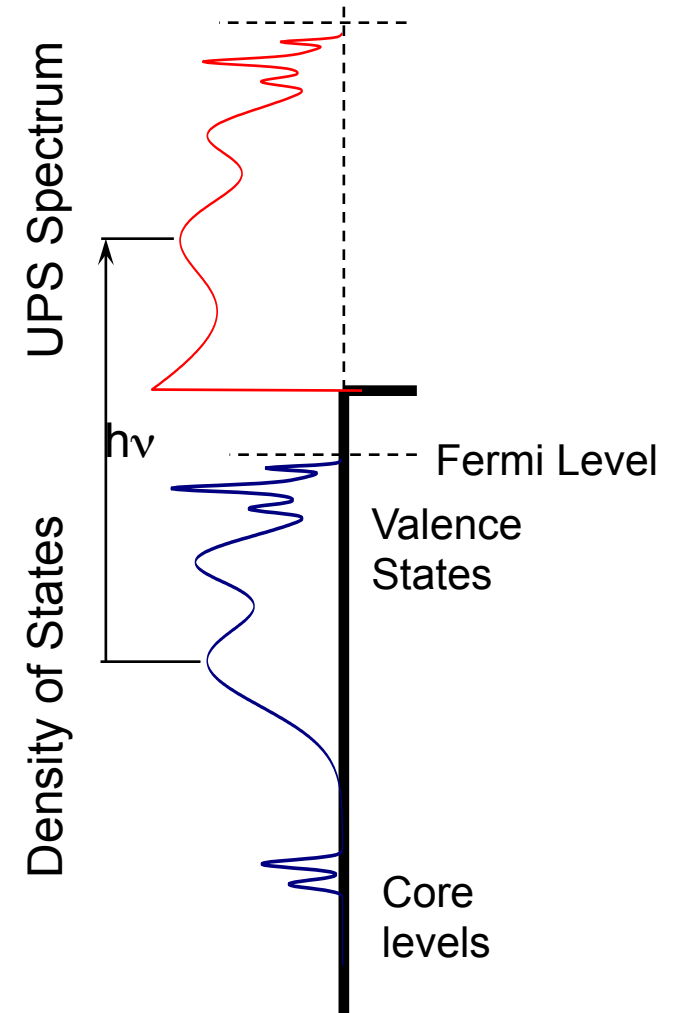
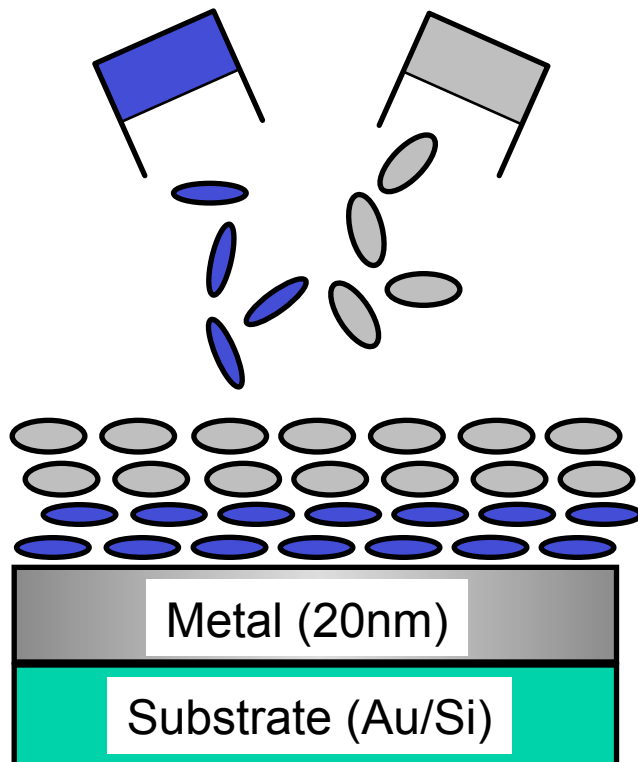

# Extracting Information from UPS Data: CBP on Au

## Energy Levels

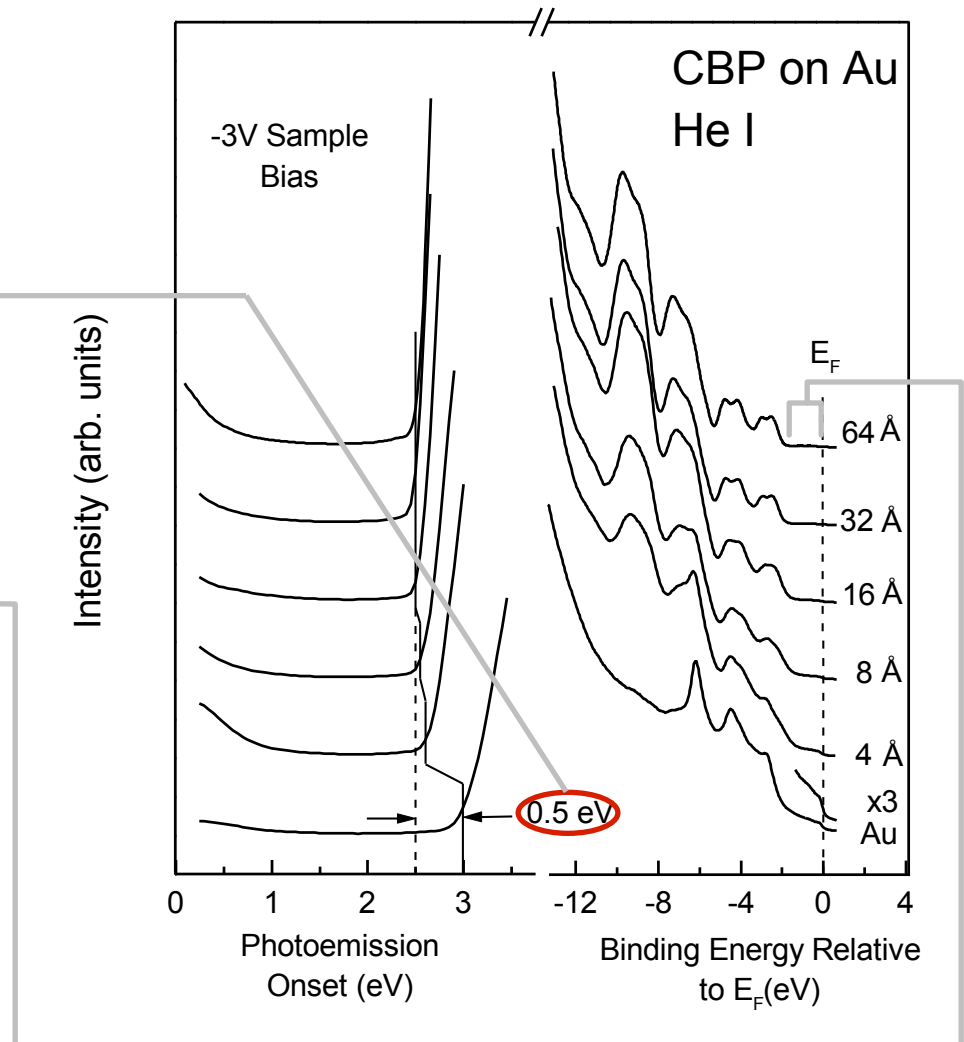
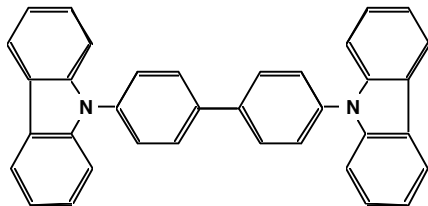
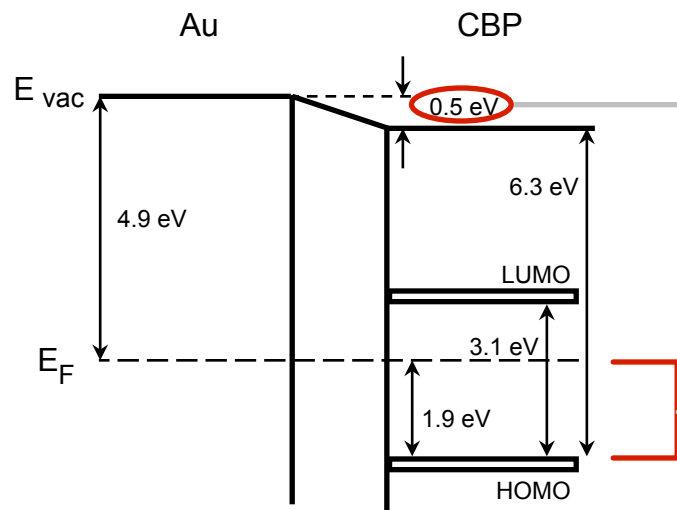

# Comparison with Theoretical DOS

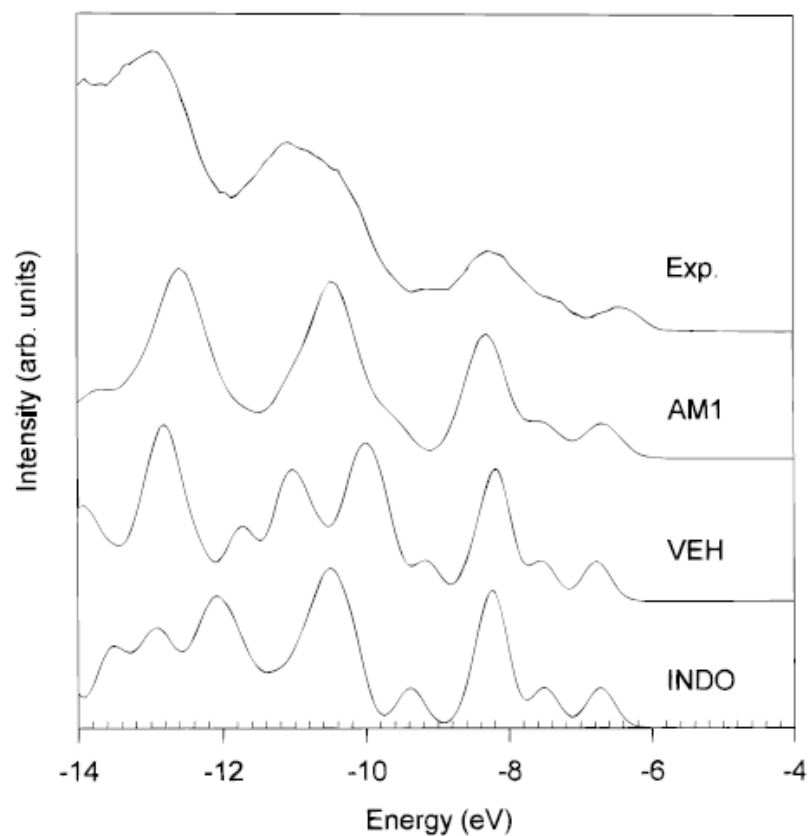
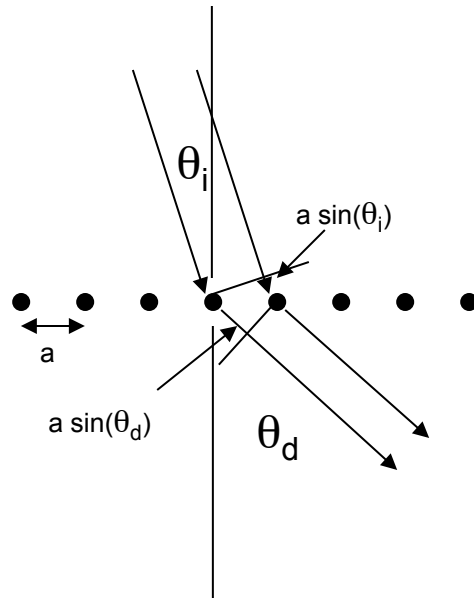

**Figure 4.** Simulated UPS spectra of the three-ring unsubstituted PPV oligomer simulated with the AM1, INDO, and VEH approaches (fwhm = 0.6 eV in all cases), compared to the solid-state experimental spectrum. The energy scale is referenced to the vacuum level.

# UPS on Single Crystal Samples

- Inorganic semiconductors: Si, Ge, GaAs, InP, etc
- Electronic wavefunctions are no longer localized
  - Crystalline periodicity and conservation of crystal momentum
  - Dispersing bands, rather than discrete energy levels
- Enables the study of crystalline energy band structure

# Elastic Scattering by a 1-D Lattice



$$\Delta path = a(\sin(\theta_d) - \sin(\theta_i)) = m\lambda = m \frac{2\pi}{|k|}$$

$$|k|(\sin(\theta_d) - \sin(\theta_i)) = m \frac{2\pi}{a}$$

$$\text{but } \Delta k_{\parallel} = |k|(\sin(\theta_d) - \sin(\theta_i))$$

$$\Delta k_{\parallel} = m \frac{2\pi}{a} = m\vec{G}, \quad m = 0, \pm 1, \pm 2, \dots$$

- Plane wave in/plane wave out
- For an outgoing wave, we need constructive interference of the scattered waves
- Constructive interference requires a path length difference of an integer multiple of wavelengths
- Elastic scattering can only occur for changes in the wave vector parallel to the lattice which are multiples of the reciprocal lattice vector,  $\mathbf{G}$
- **Result of the translational symmetry of the lattice**
- For 3-D lattice, constraints for the other dimensions

# Reduced Zone Scheme and Optical Transitions

- Bloch states can be elastically scattered by a reciprocal lattice vector
- We treat states differing by a reciprocal lattice vector as equivalent
- Optical transitions must conserve momentum and energy
- If photon momentum is  $\sim 0$  (true for UPS, not for XPS), transitions must be vertical

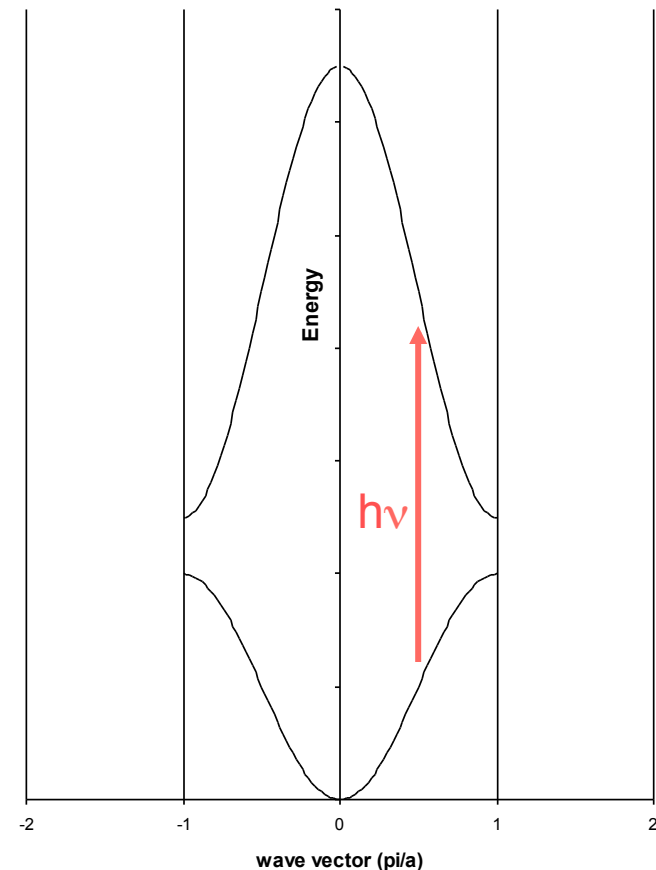



# 3-step Model of Photoemission

- 1) Photon is absorbed in an energy and momentum conserving vertical transition between an initially occupied and initially unoccupied state
- 2) Electron moves to the surface
- 3) Electron crosses the surface and escapes from the solid (more on this)

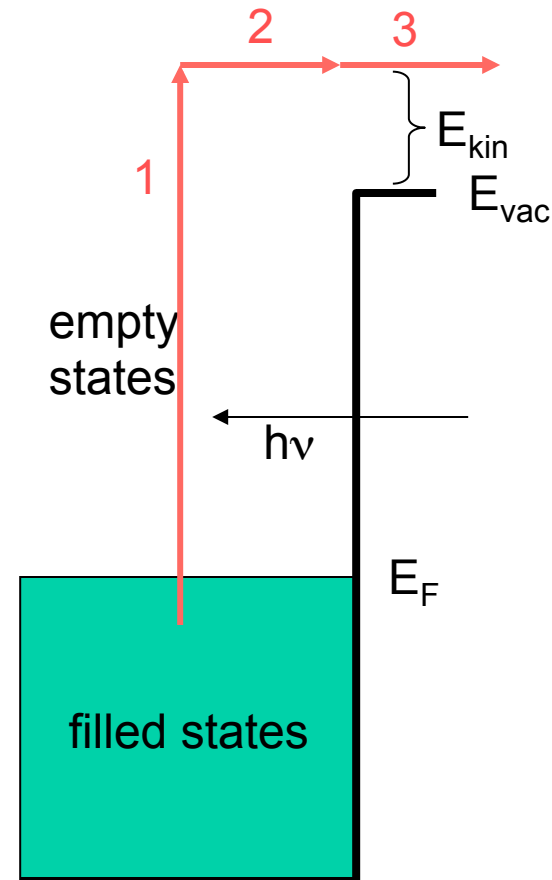

Note: this is a qualitative model that technically violates the uncertainty principal  
The "1-step model" (see Hűfner for example) is the correct model, but not as qualitatively illustrative

# Crossing the Surface of a Crystal

- Bulk crystal, by definition, is invariant under translation by basis vectors
  - Implies conservation of (crystal) momentum, ie scattering can only occur through reciprocal lattice vectors  $\{\mathbf{G}_i\}$
- Define coordinates:  $xy$  plane is the surface,  $z \perp$  surface
- When an electron crosses the surface, the periodicity is broken in the  $z$  direction, but not in the  $xy$  plane
  - Implies the  $z$  component of momentum is not conserved when crossing the surface, but  $x$  and  $y$  components are
  - Note: equivalent to Snell's law in optics
  - Electron can be scattered by  $\mathbf{G}$  vectors in the surface plane

# Crossing the Surface of a Crystal

- If we know the total momentum (or kinetic energy) of the electron, and the escape angle of the electron, we can calculate the x and y components of the momentum both outside and inside the crystal
- If we vary the angle, relative to the surface, at which the analyzer is placed (by tilting/rotating the sample or the analyzer), and take spectra at each angle, we can determine the binding energy of the electronic states as a function of x and y components of momentum
- This means we can measure the crystal band structure!
- This is known as angle-resolved photo electron spectroscopy (ARPES or ARUPS).

# Angle-Resolved UPS

- With the technique outlined, we can only measure the dispersion of two-dimensional systems (dispersion in the  $xy$  (surface) plane).
- There are many (quasi) two dimensional systems of interest:
  - Layered systems: graphite, High  $T_c$  superconductors
  - Ordered species on the surface of a metal or semiconductor
  - Surface states of metals and semiconductors
  - Image states at surfaces

# Angle Resolved UPS

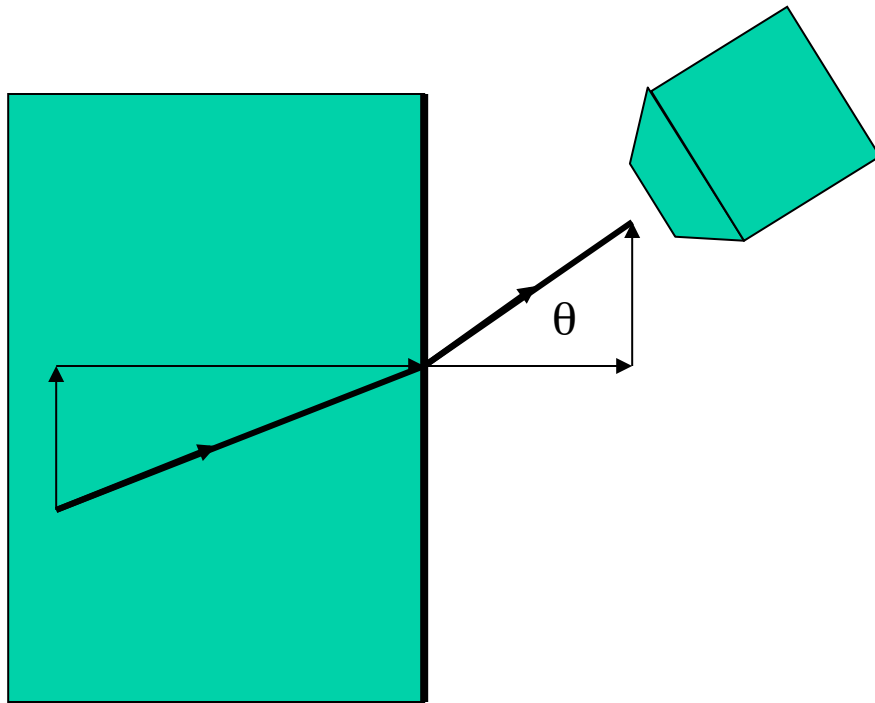

$$k_x = k_{out} \sin(\theta)$$

$$E_{out} = \frac{\hbar^2 k_{out}^2}{2m}$$

$$k_x = \left( \frac{2mE_{out}}{\hbar^2} \right)^{\frac{1}{2}} \sin(\theta)$$

What range of angles?

Assume  $E_{out} \sim 10$  eV

1<sup>st</sup> Brillouin zone boundary  $\sim 1 \text{ \AA}^{-1}$

$$\theta = \sin^{-1} \left( \frac{k_x}{k_{out}} \right)$$

$$= \sin^{-1} \left[ \left( \frac{\hbar^2 k_x^2}{2mE_{out}} \right)^{\frac{1}{2}} \right]$$

$$= \sin^{-1} \left[ \left( \frac{(6.626 \times 10^{-34} \text{ Js})^2 (10^{10} \text{ m}^{-1})^2}{8\pi^2 (9.11 \times 10^{-31} \text{ kg})(10 \text{ eV} \times 1.6 \times 10^{-19} \text{ J/eV})} \right)^{\frac{1}{2}} \right]$$

$$\theta \approx 30^\circ$$

If our analyzer has an angular resolution (acceptance angle) of  $\sim 2^\circ$ , we can measure  $\sim 15$  k-points between  $\Gamma$  and the first B.Z. boundary

# Band Structure of Graphite

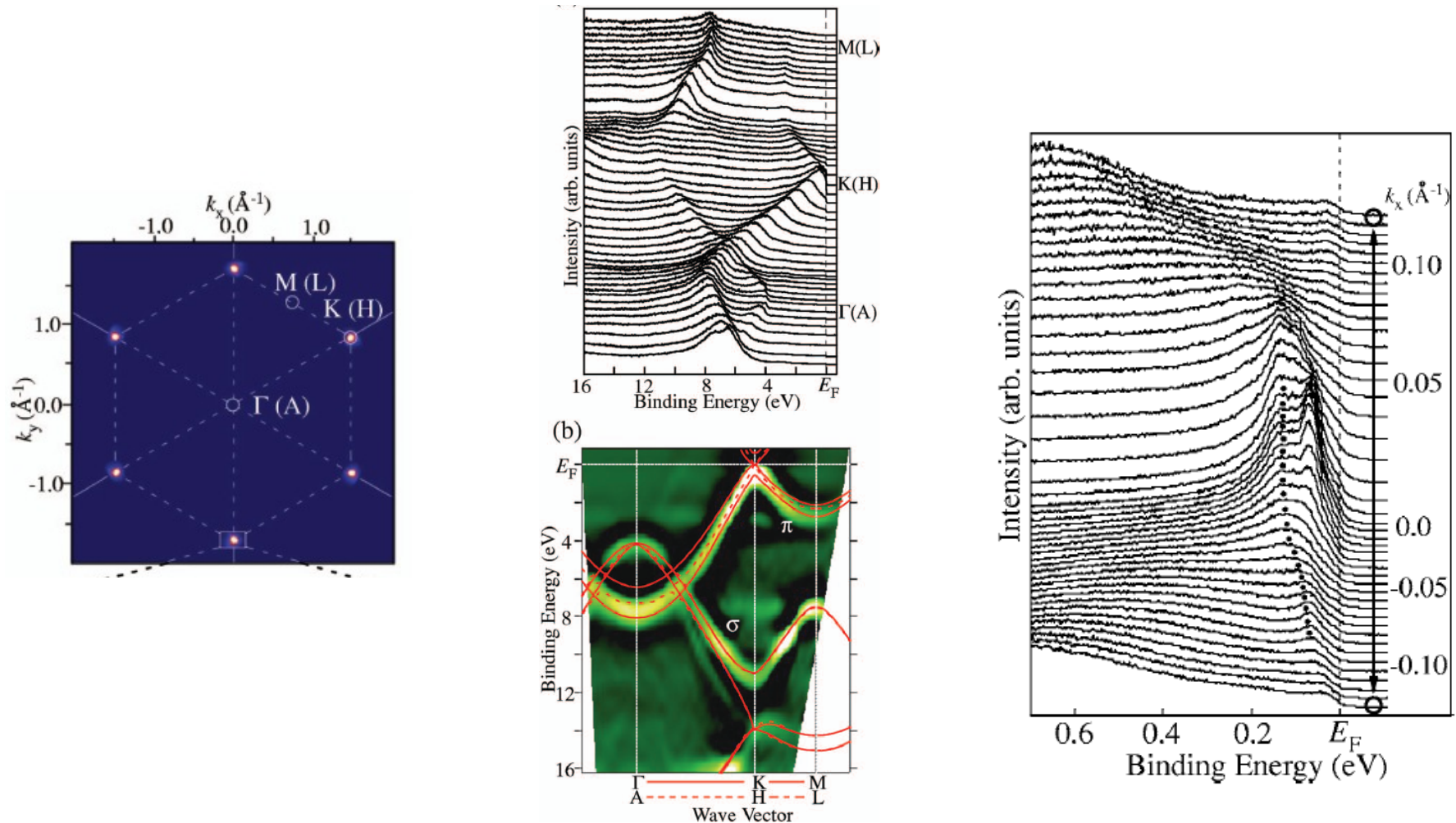

FIG. 1. (Color) (a) ARPES spectra of kish graphite measured at 20 K along the  $\Gamma$ KM direction using He  $\text{II}\alpha$  resonance line. (b) The experimental band structure of graphite (bright areas) obtained by plotting the second derivative of ARPES-spectral intensity as function of wave vector and binding energy, compared with the modified first-principles band structure calculation (red lines) (Ref 17).

Sugawara *et al*  
 Phys Rev B 73 (4) (2006)

# Why can't we do the same thing with XPS?

- The momentum of an x-ray photon is significant compared to the momentum of the electrons in the solid.
  - Transitions are not vertical, so we don't know the momentum of the initial state even if we measure that of the photoelectron
- Because the kinetic energies of the photoelectrons are so large (1.5 keV), the angle at the first boundary is only 1-2°
- Using XPS to measure valence states results in an *angle integrated*, not resolved measurement

# Can we measure 3D band structures with UPS?

- Yes! but only at a synchrotron...
- Problem: for a (vertical) optical transition to occur within the 3D band structure, the initial and final states (at the same momentum) must be separated by an energy equal to the photon energy
- We need to be able to scan the photon energy in order to observe transitions
- Very complicated, requiring knowledge (or assumptions) about the final state (ie free electron-like at high kinetic energies)
- See S. Hüfner, "Photoelectron Spectroscopy", section 7.3 for discussion

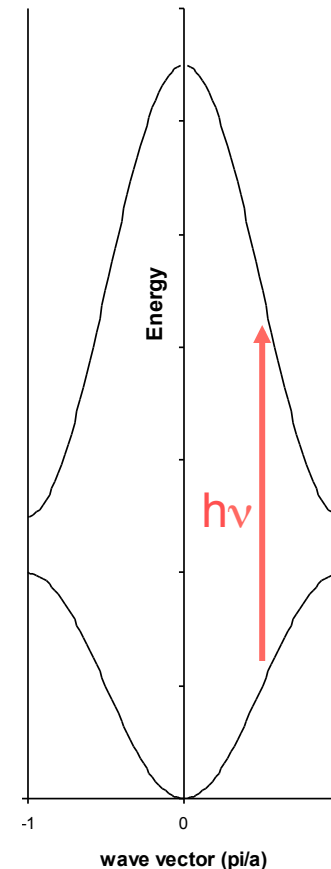



# Angular Resolved Spectra from Cu(110)

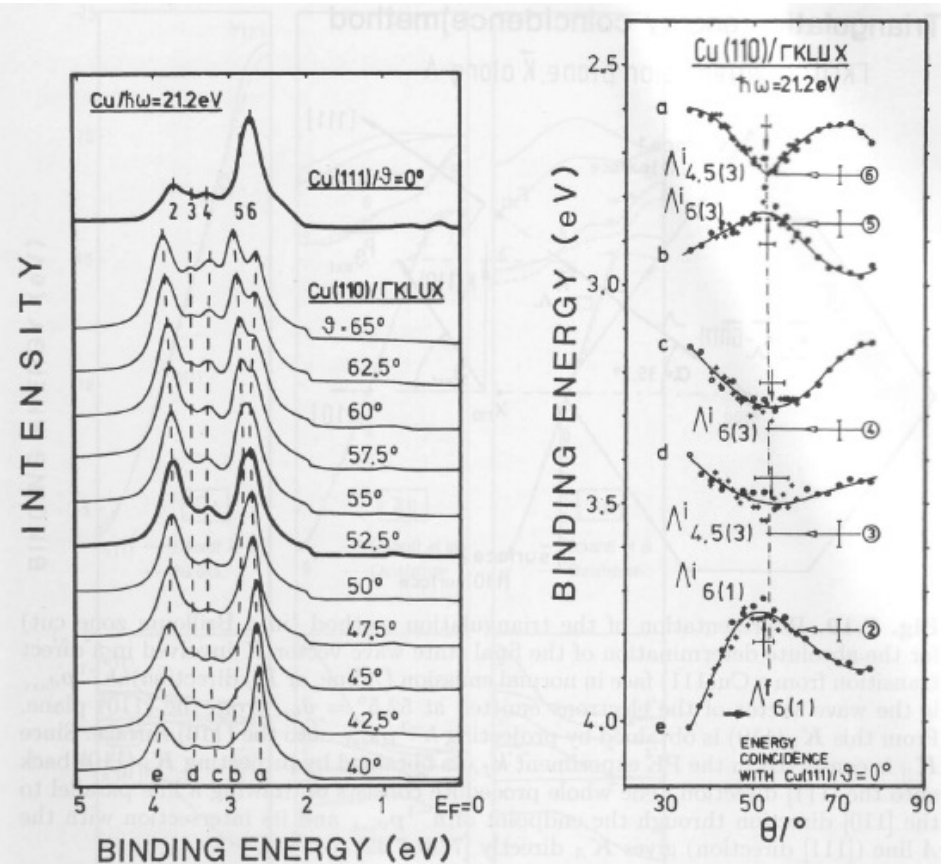

**Fig. 7.9.** *Left:* EDCs taken with  $\hbar\omega = 21.2$  eV from a (110) surface in the  $\Gamma$ KLUX plane for varying electron detection angle  $\theta$ . The top spectrum is a normal emission spectrum from a (111) surface. The  $\theta = 52.5^\circ$  spectrum from the (110) surface (*thick line*) is the one for which the positions of the peaks correspond most closely in energy to those from the (111) normal emission spectrum (therefore also the term energy coincidence method). *Right:* peak positions taken from the spectra in the left panel, as a function of electron detection angle  $\theta$ . Also given are the energies of the peaks (2), (3), (4), (5), (6) of the Cu(111) normal emission spectrum [7.39]. Note, that the “energy coincidence” generally occurs well within the error bars of typically only  $\pm 0.07$  eV

# Band Structure of Cu: UPS and Theory

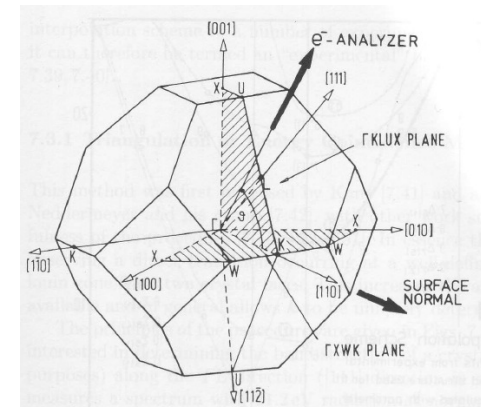
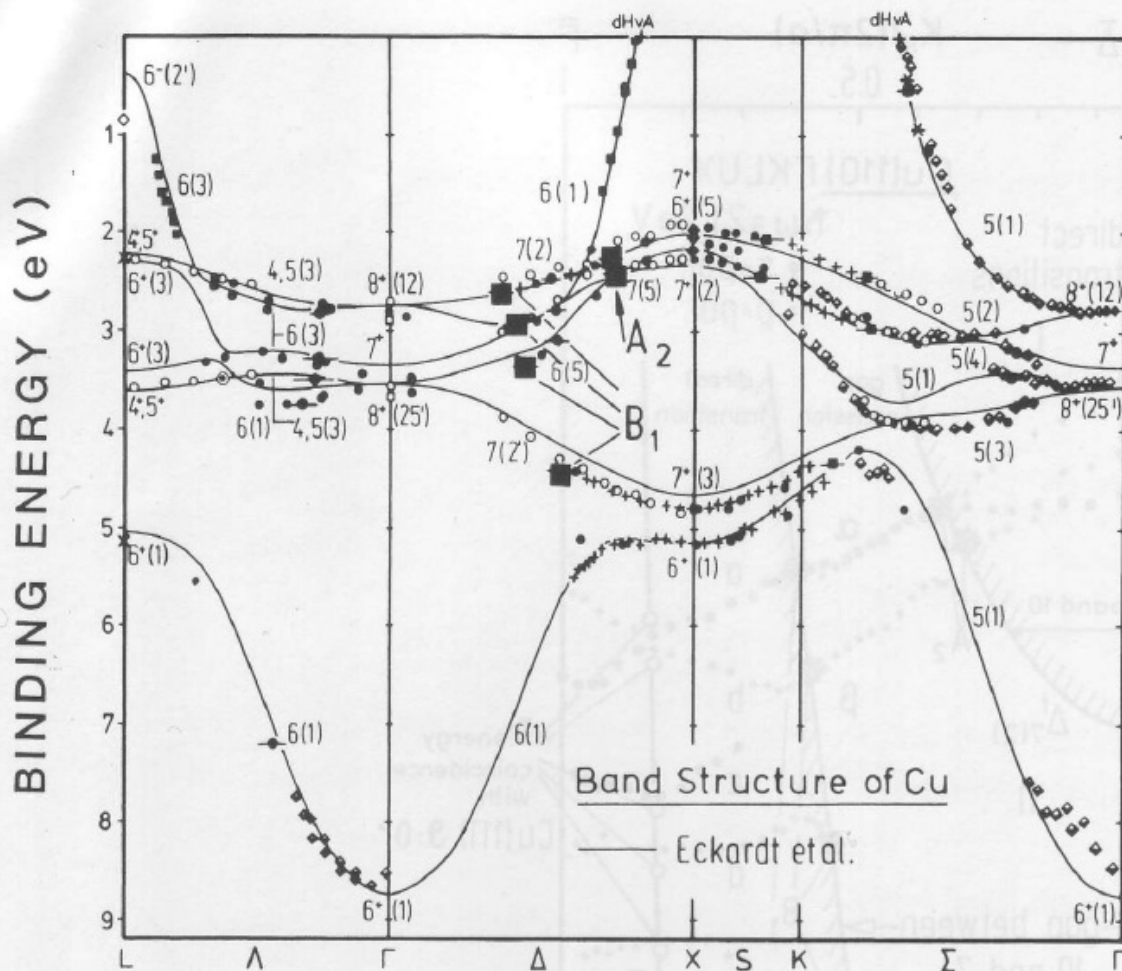

Fig. 7.17. Occupied part of the band structure of Cu [7.39] with data points from various sources and a theoretical result [7.53]. Also shown (*squares*) are the two  $A_2$  points and the four  $B_1$  points from Fig. 7.16