



Thermal Desorption Spectroscopy on powders

12th January 8

Elias Frei

Fritz Haber Institute, Inorganic Chemistry Department
efrei@fhi-berlin.mpg.de

Literature

- R.I. Masel, Principles of adsorption and reaction on solid surfaces, Wiley, 1996.
- J.W. Niemantsverdriet, Spectroscopy in catalysis, Wiley, 2000
- Previous TDS seminars by D. Teschner, W. Ranke and D. Rosenthal
- K. Christmann, Introduction to Surface Physical Chemistry, Steinkopff-Verlag, Darmstadt 1991

Surface Science 525 (2003) 184–196

J.M. Gottfried *, K.J. Schmidt, S.L.M. Schroeder, K. Christmann

J. Phys. Chem. C **2008**, *112*, 18543–18550

Luis K. Ono and Beatriz Roldan Cuenya*

The idea behind TDS!

Adsorbed particles with different *binding energies* will desorb at different *temperature*.

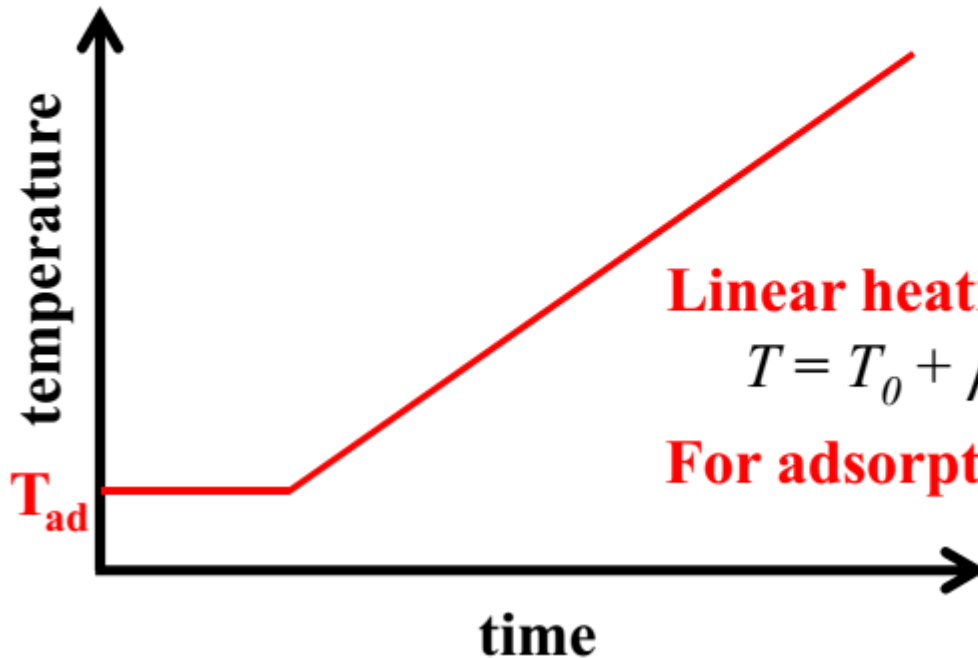

A: Pre-adsorbed species

B: Removed from the surface by T

C: Detection of the desorbing species



TDS signal / curve:

Peaks can be analyzed, qualitatively and quantitatively!

Outline

1. Fundamentals of adsorption/desorption
2. Different TDS/TPD Setups
3. Curves and Evaluation methods
4. A new TDS setup: Between UHV and TPD!
5. Results and Limitations!
6. Summary

Fundamentals: Adsorption kinetics

Rate of Adsorption $R_{\text{ads}} = S * F$ in $1/(m^2*s)$

$$F = P / (2\pi mk_b T)^{1/2}$$

Hertz-Knudsen equation:
Flux of incident molecules

Sticking probability: $S = f(\theta) \cdot \exp(-E_a / RT)$

$$R = \frac{f(\theta) \cdot P}{\sqrt{2\pi mkT}} \exp(-E_a / RT)$$

Fundamentals: Adsorption/Desorption Thermodynamics

Gibbs energy decreases for spontaneous processes,
 $\Delta G < 0$.

$$\Delta G = \Delta H - T\Delta S$$

Adsorption confines the gas to the surface: $\Delta S < 0$.

➤ for spontaneous adsorption ΔH is negative (exothermic).

➤ for desorption extra energy is needed.

Reversibility: At microscopic scale depending on the energy,
at macroscopic scale averaging in equilibrium.

Fundamentals: Adsorption Thermodynamics

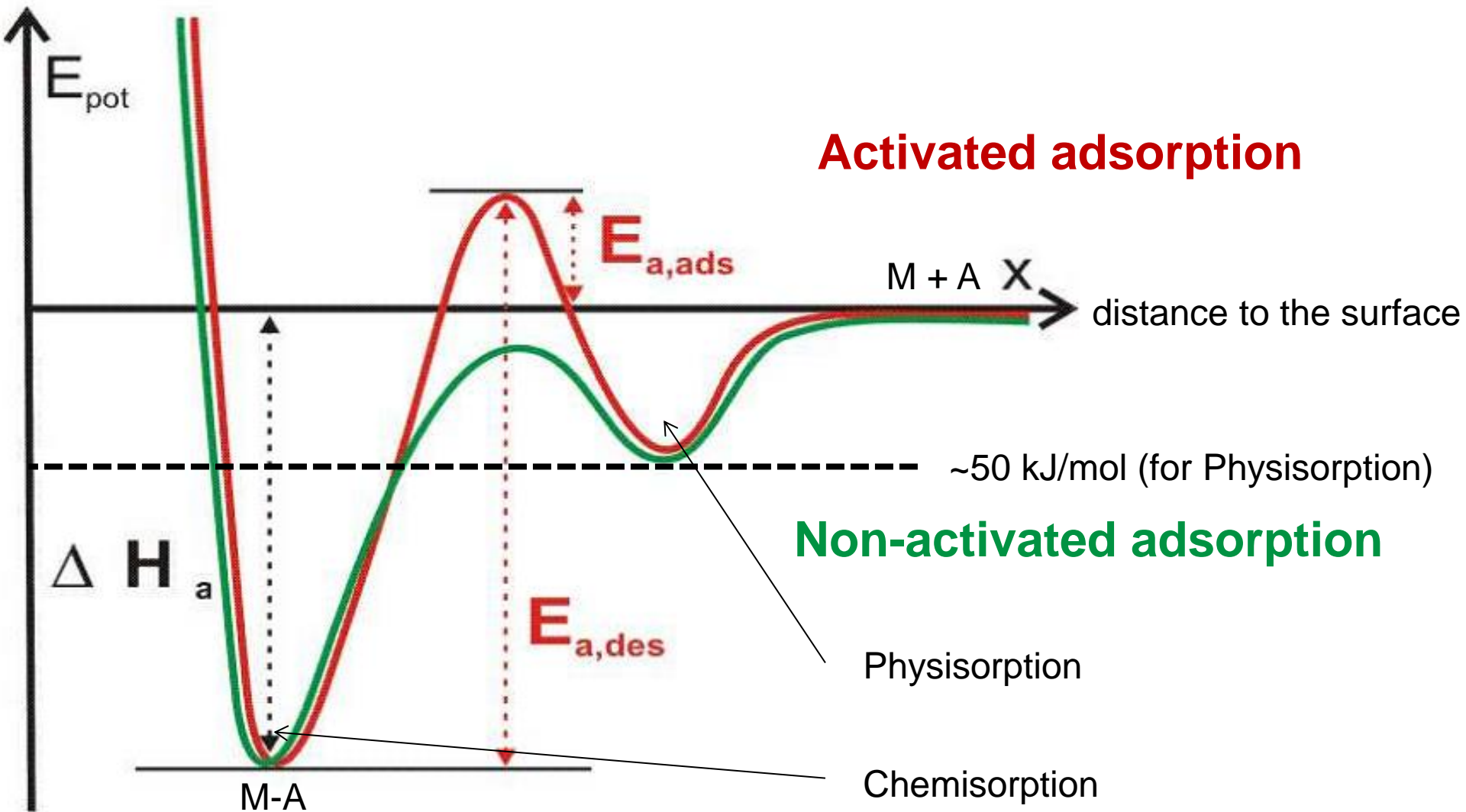

Fundamentals: Desorption Kinetics

Polanyi-Wigner equation

$$r_{des} = -\frac{d\Theta}{dt} = v_n \cdot \exp\left(-\frac{\Delta E_{des}^{PW}}{RT}\right) \cdot \Theta^n$$

E_{des} : activation energy of desorption

Θ : coverage

v_{des} : pre-exponential factor

n : order of desorption

Fundamentals: Desorption Kinetics

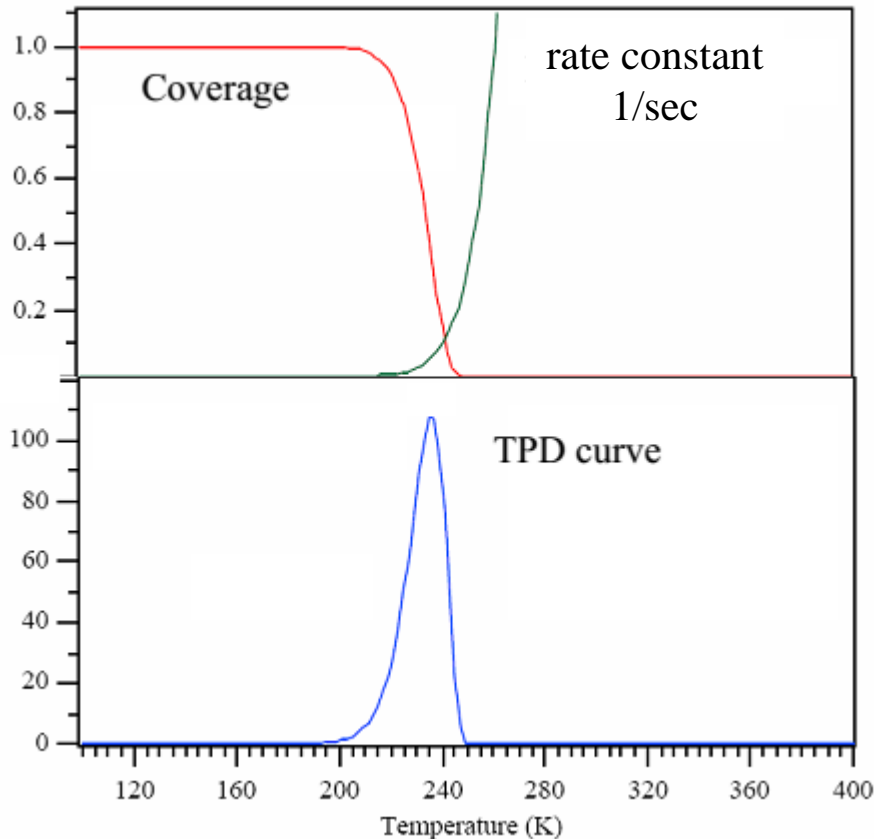

$$r_{des} = -\frac{d\Theta}{dt} = \nu_n \cdot \exp\left(-\frac{\Delta E_{des}^{PW}}{RT}\right) \cdot \Theta^n$$

TPD curve represents
the desorption rate

Order of Desorption

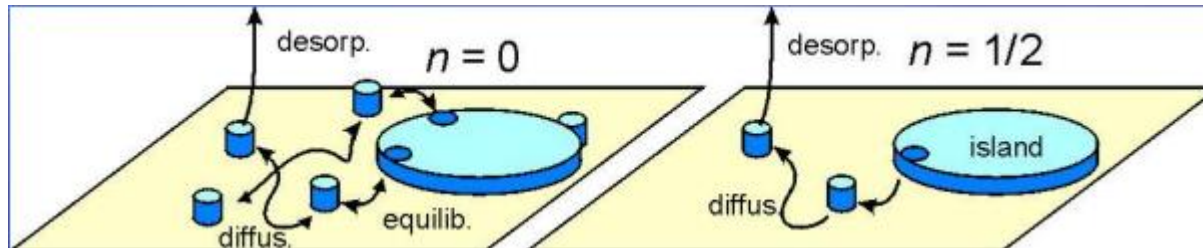

0: rate independent of coverage; fast exchange with an “infinite” reservoir; e.g. evaporation, sublimation, surface species replenished from bulk

0.5: desorption occurs from the perimeter of i.e. a cluster/edge of a cluster

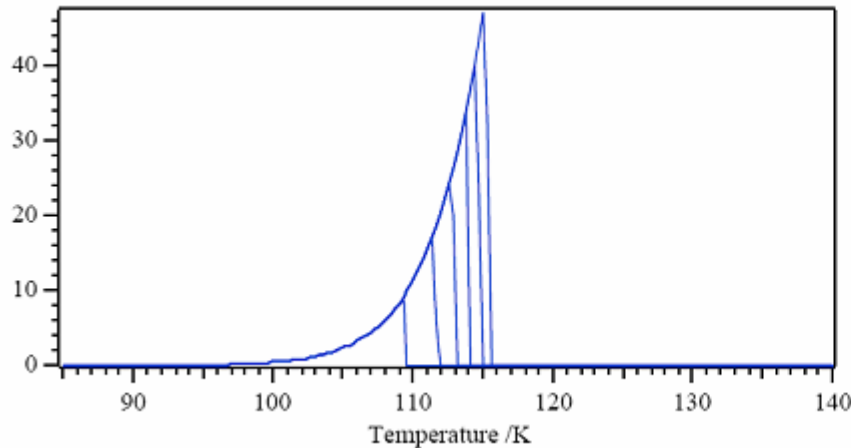

i) Zero-order kinetics:

- multilayer desorption
- unlimited supply of particles (no coverage dependence)
- common leading edges

Order of Desorption

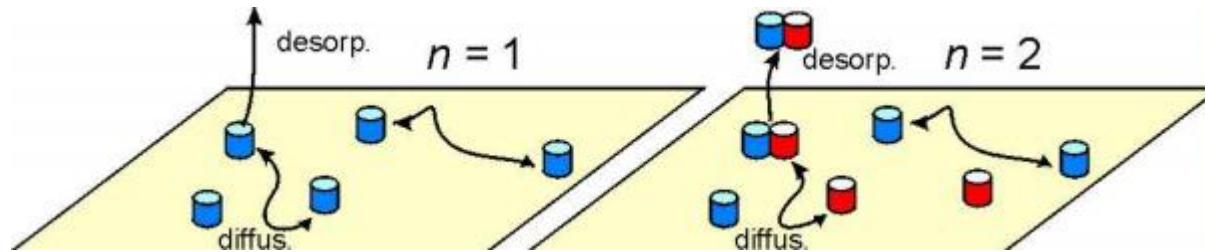

1: classical molecular desorption: **rate proportional to Θ^1**

2: associative desorption, the coverage of 2 species matters, mobility of 1 species is needed: **rate proportional to Θ^2**

ii) First-order kinetics:

unimolecular desorption

$I(T) \sim$ no. of particles

peak position independent of θ

asymmetric peak shape

iii) Second-order kinetics:

recombinative desorption

$I(T) \sim$ no. of particles (no. of particles -1) $\sim \theta^2$

peak position shifts to lower T with increasing θ

symmetric peak shape

common trailing edges

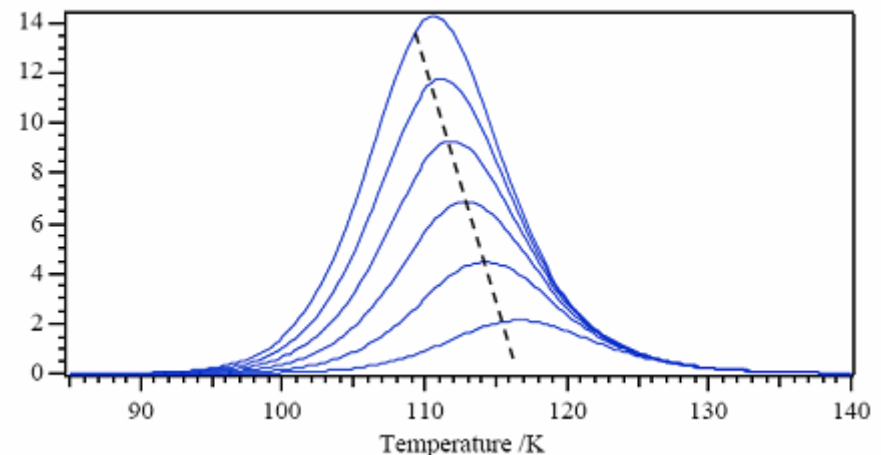
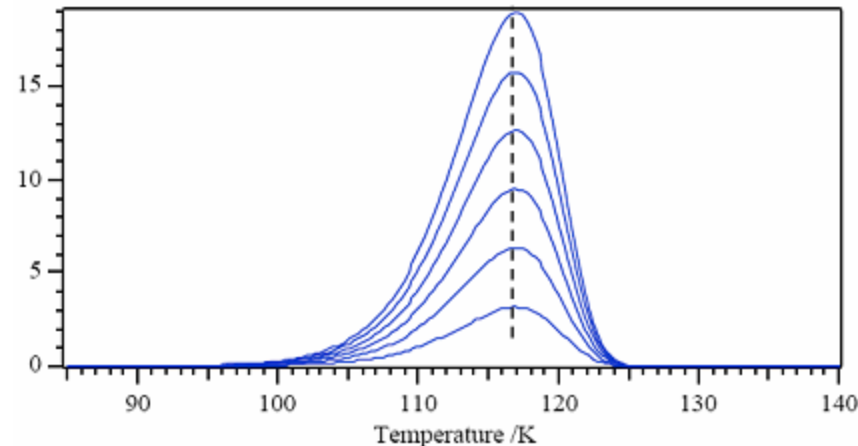

The pre-exponential or frequency factor

Using transition state theory

$$v_{des} = \kappa \frac{kT}{h} \frac{q_{\ddagger}}{q_{ad}} = e\kappa \frac{kT}{h} \exp\left(\frac{\Delta S^{\ddagger}}{R}\right)$$

κ : transmission coefficient

k, h : Boltzmann and Planck constants

q : partition function of transition and adsorbed state

ΔS^{\ddagger} : entropy of activation

If $q_{\ddagger}/q_{ad} = 1$, $v_{des} \cong 10^{13} \text{ s}^{-1}$ at RT

The pre-exponential or frequency factor

Molecular Desorption



Similar freedom for adsorbed and transition states

More rotational and translational freedom for transition state

$$r = A [\exp -(E_s/k_B T)] \theta_A$$

$$A = 10^{13}/s$$

$$A = 10^{16}/s$$

Associative Desorption



Mobile adsorbed and transition states with full rotational freedom

Mobile adsorbed and transition states without rotation

Immobile adsorbed and transition states

Immobile species with more rotational and translational freedom for transition state

$$r = A [\exp -(E_s/k_B T)] (\theta_A)^2$$

$$A = 10^8/s$$

$$A = 10^{11}/s$$

$$A = 10^{13}/s$$

$$A = 10^{16}/s$$

Information from TPD curves

Parameters governing TDS peak T

- E_{des}
- Pre-exponential
- Coverage
- Desorption order
- Heating rate

Differential and integral methods for data analysis

Complete analysis, after King

(D.E. King, T.E. Madey, J.T. Yates, Jr., J. Chem. Phys. 55 (1971) 3236).

“Leading edge” method (E. Habenschaden, J. Küppers, Surf. Sci. 138 (1984) L147)

HRV Method Falconer, J. L.; Madix, R. J. Surf. Sci. 1975, 48, 393

CAW-Method Chan, C. M.; Aris, R.; Weinberg, W. H. Appl. Surf. Sci. 1978, 1, 360.

Single TD-spectrum: Redhead’s analysis

(P.A. Redhead, Vacuum 12 (1963) 203)

Size Effects on the Desorption of O₂ from Au₂O₃/Au⁰ Nanoparticles Supported on SiO₂: A TPD Study

Luis K. Ono and Beatriz Roldan Cuenya*

Department of Physics, University of Central Florida, Orlando, Florida 32816

Received: July 23, 2008; Revised Manuscript Received: September 8, 2008

18548 *J. Phys. Chem. C, Vol. 112, No. 47, 2008*

Ono and Roldan Cuenya

TABLE 1: Summary of the Kinetic Parameters [Desorption Order, Desorption Energy and Pre-exponential Factor] Obtained from Our O₂ TPD Measurements on ~5 nm (Sample #1) and ~1.5 nm (Sample #3) Au Nanoparticles Deposited on SiO₂ Using Different Analysis Methods^a

sample	analysis method	desorption order (<i>n</i>)	desorption energy (<i>E_d</i>)	pre-exponential factor (<i>ν_a</i>)	comments
Au NPs ~5 nm/SiO ₂	Arrhenius				no linear fit
	HRV	* <i>n</i> = 1	1.2 ± 0.1 eV	1 × 10 ^{10±1} s ⁻¹	θ ₀ = 0.22 ML β = 0.1~5 K/s
		* <i>n</i> = 2	1.2 ± 0.1 eV	4 × 10 ^{10±1} ML ⁻¹ s ⁻¹	
	Redhead	* <i>n</i> = 1	1.5 eV	*1 × 10 ¹³ s ⁻¹	θ ₀ = 0.22 ML β = 5 K/s T _{max} = 555 K
		* <i>n</i> = 2	1.4 eV	*1 × 10 ¹³ ML ⁻¹ s ⁻¹	
	complete analysis	* <i>n</i> = 1	1.3 ± 0.1 eV	1 × 10 ^{11±1} s ⁻¹	θ' = 0.04 ML β = 5 K/s
			1.3 ± 0.1 eV	6 × 10 ^{10±1} s ⁻¹	θ' = 0.12 ML β = 5 K/s
			1.5 ± 0.1 eV	6 × 10 ^{12±1} s ⁻¹	θ' = 0.17 ML β = 5 K/s
		* <i>n</i> = 2	1.3 ± 0.1 eV	3 × 10 ^{12±1} ML ⁻¹ s ⁻¹	θ' = 0.04 ML β = 5 K/s
			1.3 ± 0.1 eV	5 × 10 ^{11±1} ML ⁻¹ s ⁻¹	θ' = 0.12 ML β = 5 K/s
		1.5 ± 0.1 eV	4 × 10 ^{13±1} ML ⁻¹ s ⁻¹	θ' = 0.17 ML β = 5 K/s	
	ln (-dθ/dt) vs ln (θ)	<i>n</i> = 1.0 ± 0.1			β = 5 K/s T _{max} = 555 K
	simulation	<i>n</i> = 1	1.5 eV	1 × 10 ¹³ s ⁻¹	θ ₀ = 0.22 ML β = 5 K/s
Au NPs ~1.5 nm/SiO ₂	Arrhenius	<i>n</i> = 2	1.6 ± 0.1 eV	7 × 10 ^{14±1} ML ⁻¹ s ⁻¹	θ ₀ = 0.31 ML β = 5 K/s
	HRV	* <i>n</i> = 2	1.7 ± 0.1 eV	2 × 10 ^{15±1} ML ⁻¹ s ⁻¹	θ ₀ = 0.26 ML β = 0.7~5 K/s
	Redhead	* <i>n</i> = 2	1.5 eV	*1 × 10 ¹³ ML ⁻¹ s ⁻¹	θ ₀ = 0.26 ML β = 5 K/s T _{max} = 584 K
		* <i>n</i> = 2	1.6 eV	*1 × 10 ¹⁴ ML ⁻¹ s ⁻¹	
	complete analysis	* <i>n</i> = 2	1.2 eV	3 × 10 ^{11±1} ML ⁻¹ s ⁻¹	θ' = 0.02 ML β = 5 K/s
			1.3 eV	3 × 10 ^{12±1} ML ⁻¹ s ⁻¹	θ' = 0.035 ML β = 5 K/s
			2.0 eV	2 × 10 ^{18±1} ML ⁻¹ s ⁻¹	θ' = 0.05 ML β = 5 K/s
			2.2 eV	1 × 10 ^{19±1} ML ⁻¹ s ⁻¹	θ' = 0.09 ML β = 5 K/s
	simulation	* <i>n</i> = 2	1.7 eV	1.2 × 10 ¹⁴ ML ⁻¹ s ⁻¹	θ ₀ = 0.31 ML β = 5 K/s

Different TDS/TPD Setups!

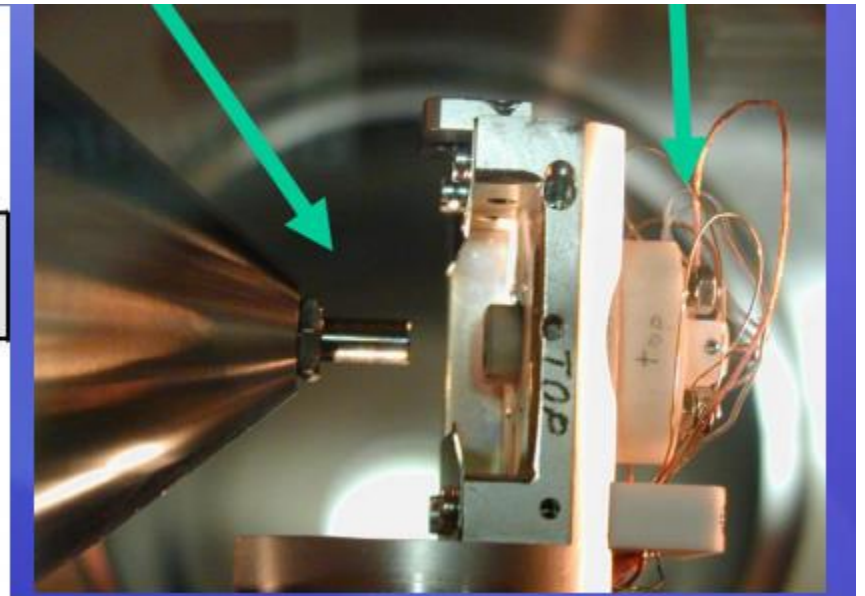
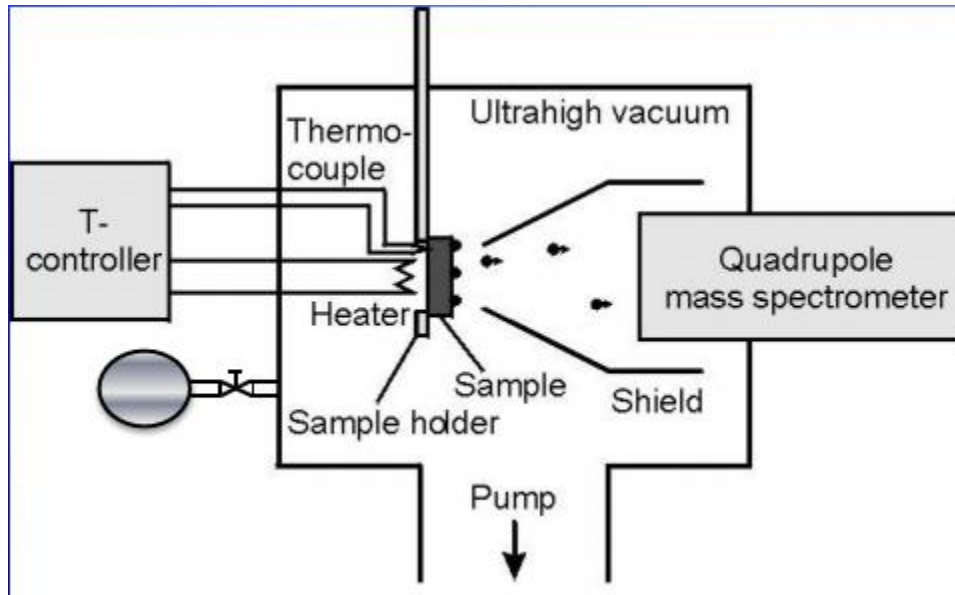

Different TDS/TPD Setups!

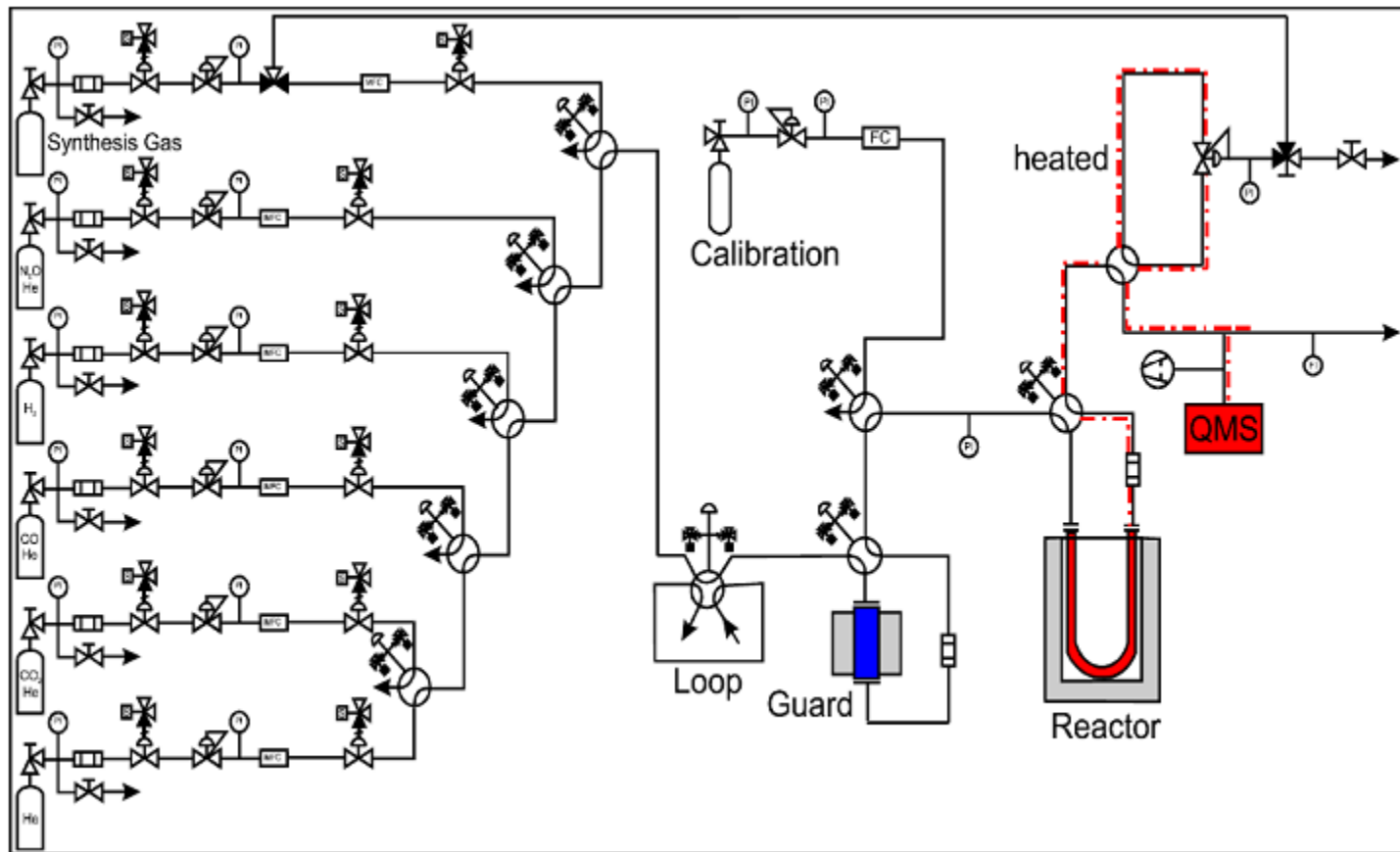

Different Coverages in TPD

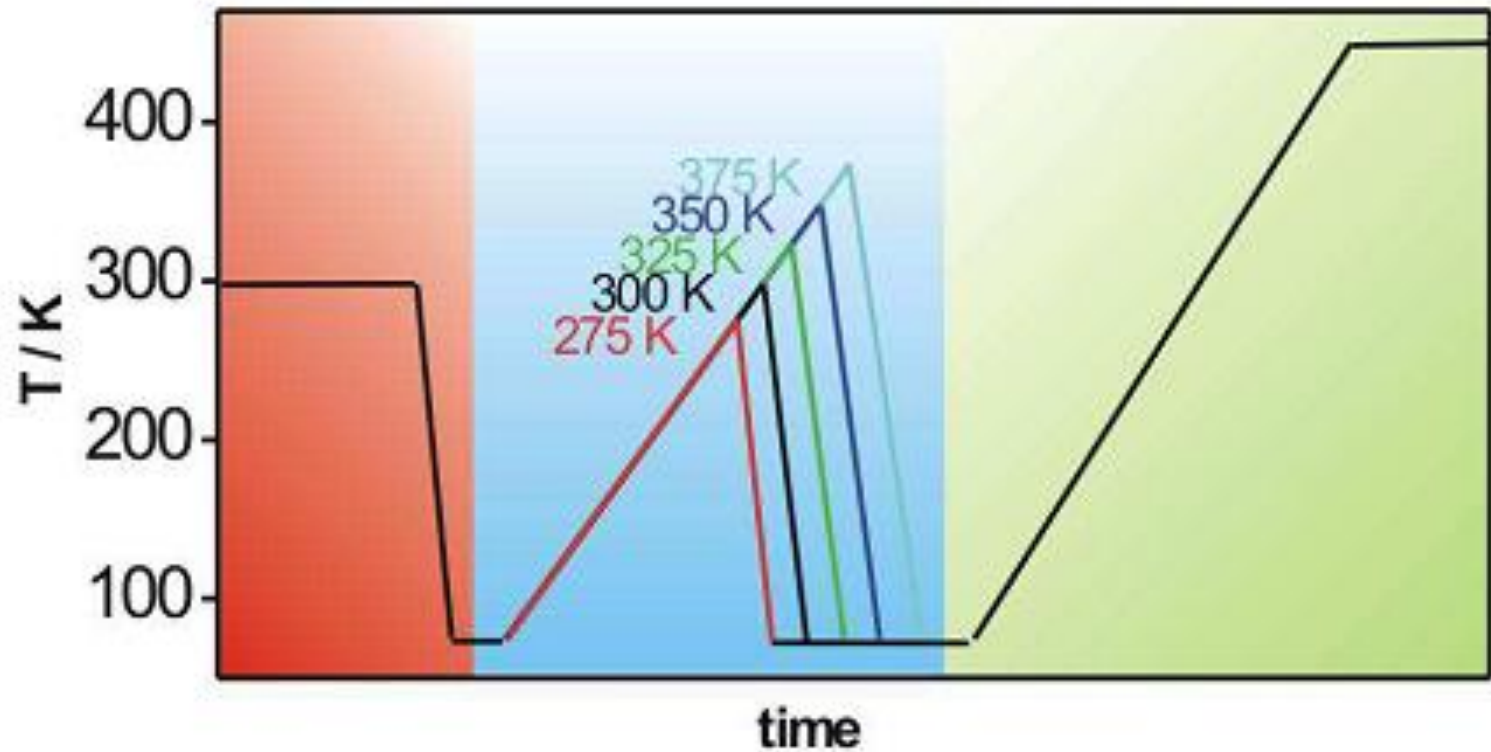

Challenges for powder TDS/TPD

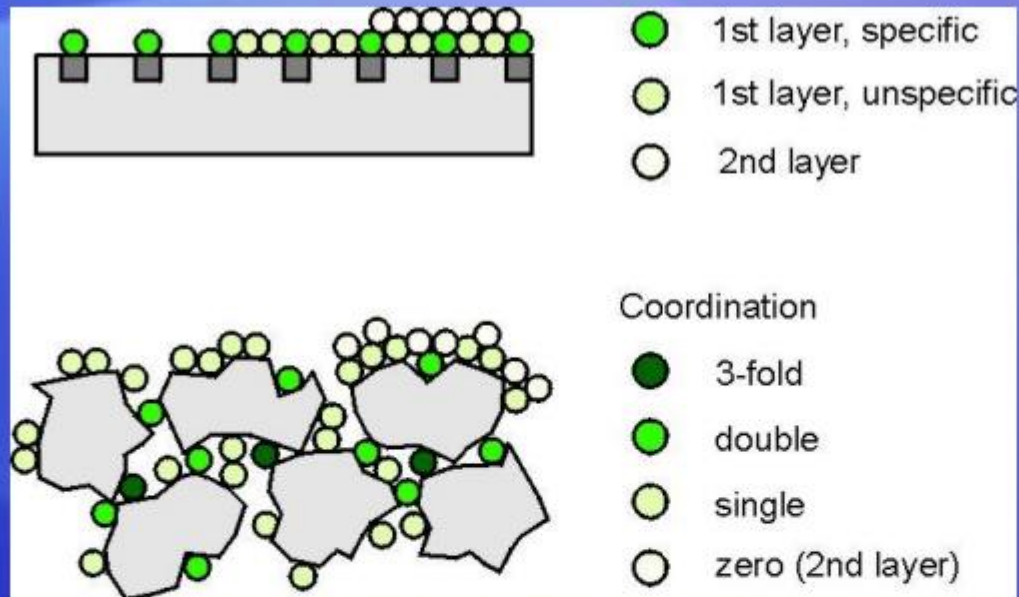

Powder: additional inhomogeneity from roughness: sites with different coordination to the substrate; desorption includes pore diffusion even in UHV.

During TPD with inert gas flow, pore diffusion an issue: peak form is largely affected by the rate of diffusion.

Challenges for powder TDS/TPD

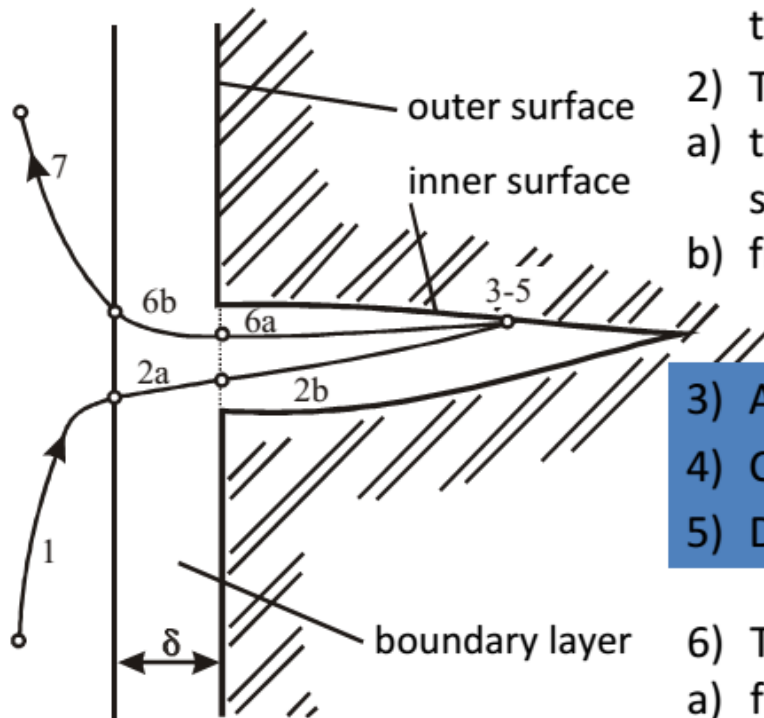

Very frequently:
inner surface \gg outer surface

- 1) Transport of the reactants from the fluid bulk to the boundary layer
- 2) Transport of the reactants to the surface
 - a) through the boundary layer to the outer surface
 - b) from the outer surface to the inner surface
- 3) Adsorption (chemisorption) of the reactant
- 4) Chemical reaction
- 5) Desorption of the product
- 6) Transport of the products to the fluid bulk
 - a) from the inner surface to the outer surface
 - b) from the outer surface through the boundary layer
- 7) Transport of the products from the boundary layer to the fluid bulk

A new TDS setup!

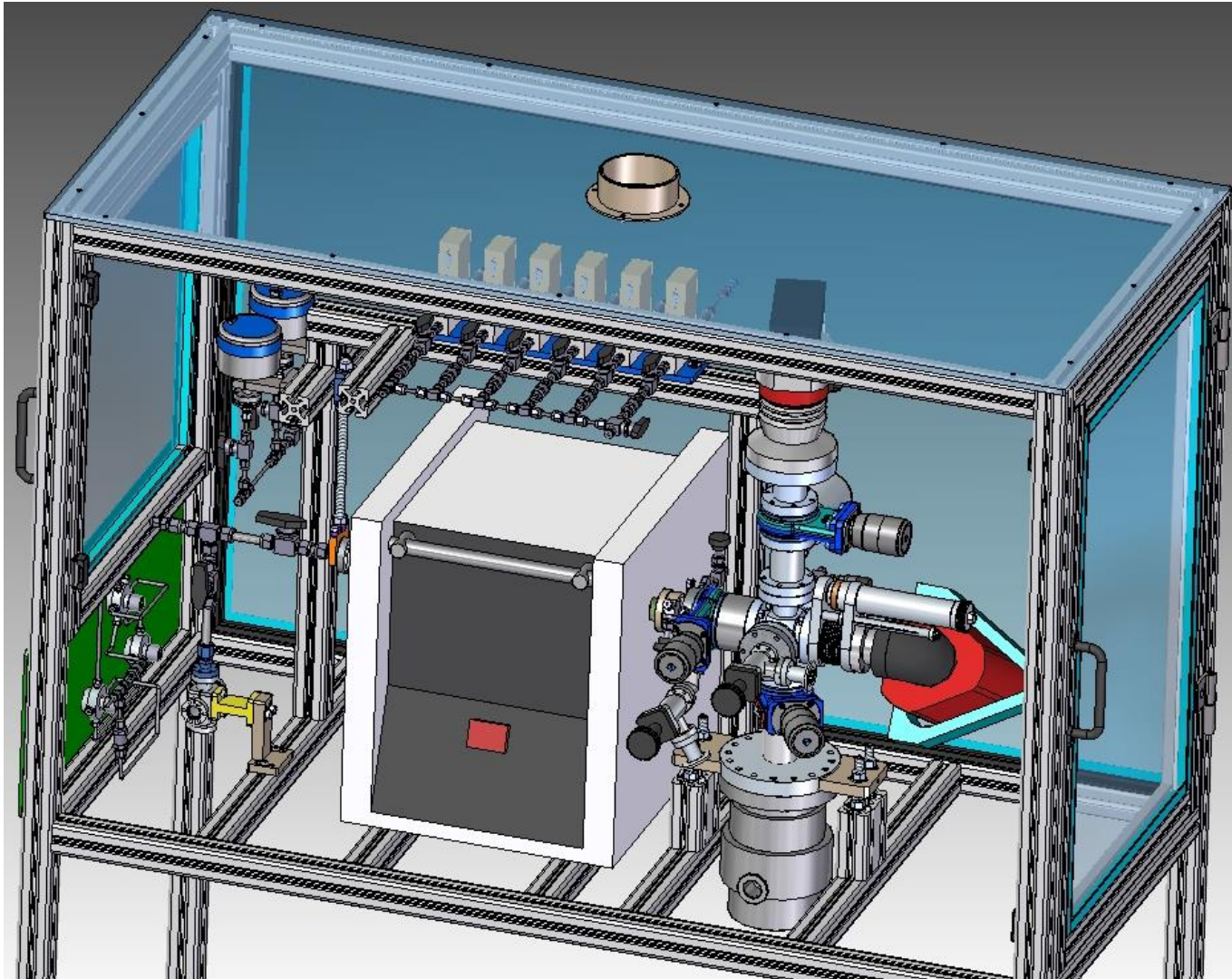

A new TDS setup!

sample

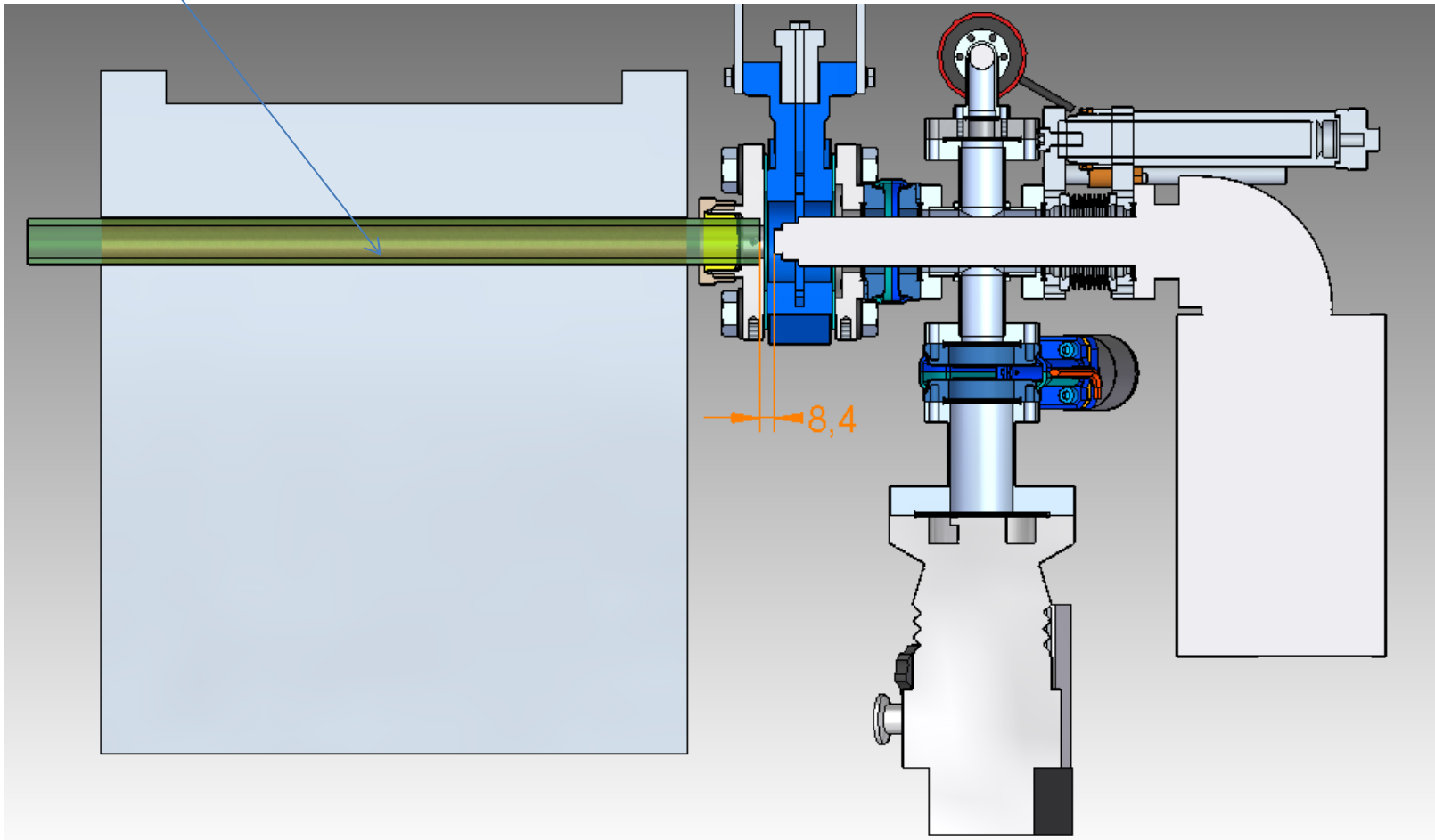

A new TDS setup!

1. Sample has to be properly pre-treated: Activated / cleaned / reduced etc.
2. Adsorption process at dedicated T and t!
3. Bring from 1 bar to $2 \cdot 10^{-6}$ mbar!
4. Move MS to the end of the oven!
5. Start Desorption with constant heating rate!

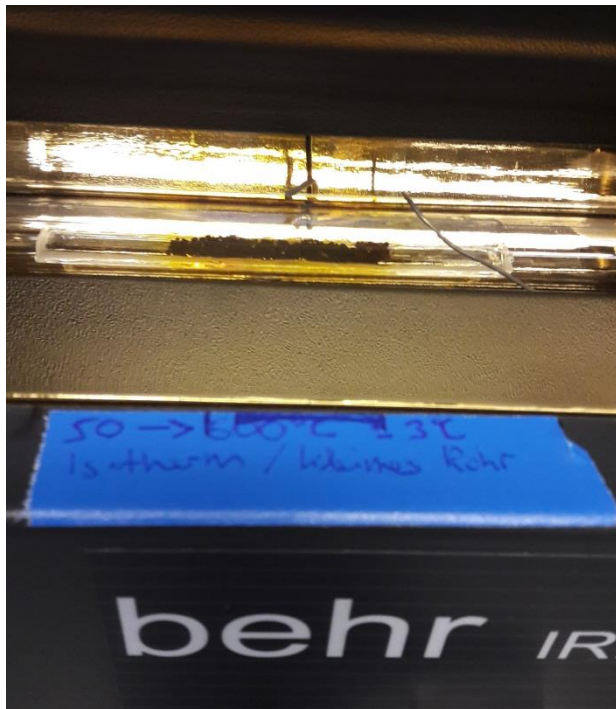

Oxygen TDS on Ag powder

The pretreatment temperature (200-350 °C) shifts the desorption maximum to higher temperatures and new desorption events are created.

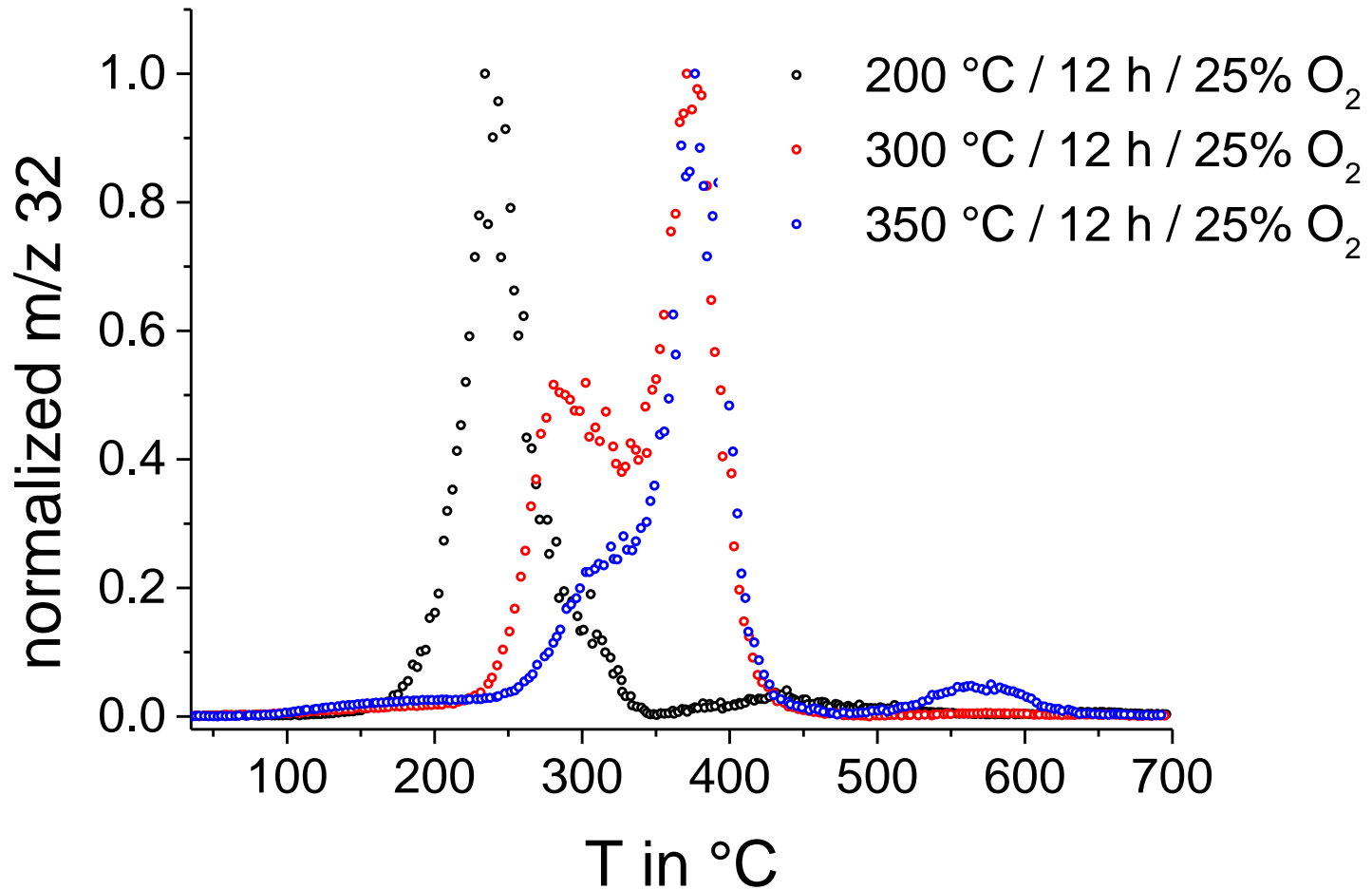

Oxygen TDS on Ag powder

The only desorption event which is recovering belongs likely to oxygen dissolved in the Ag bulk invisible for supported samples.

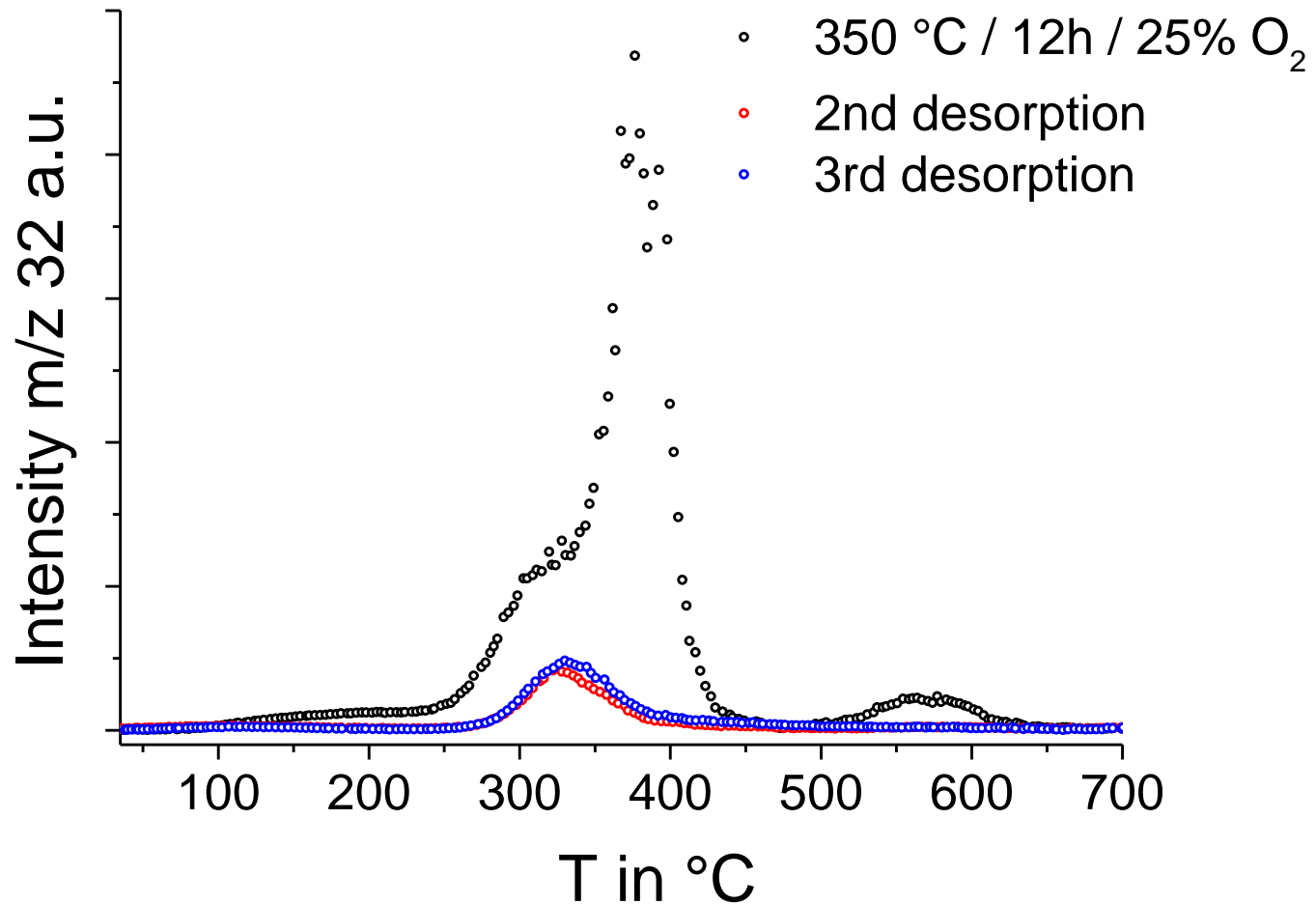

Oxygen TDS on Ag@ α -Al₂O₃

Only one main de-sorption event is visible independent from the pre-treatment temperature.

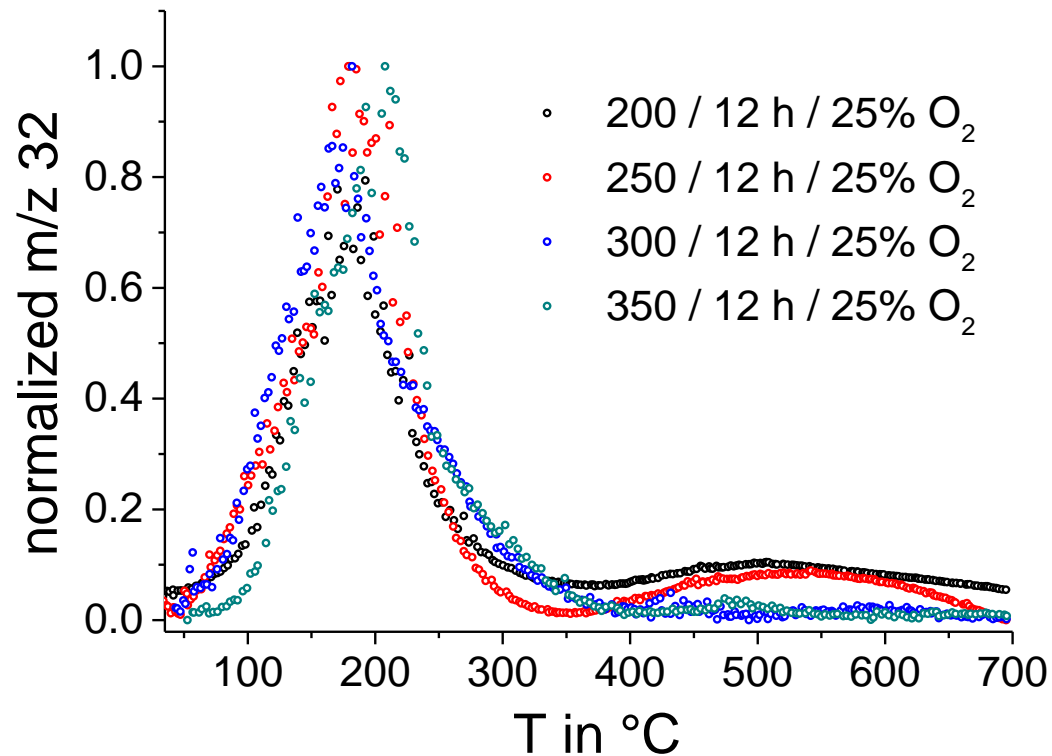

High quality powder TDS data

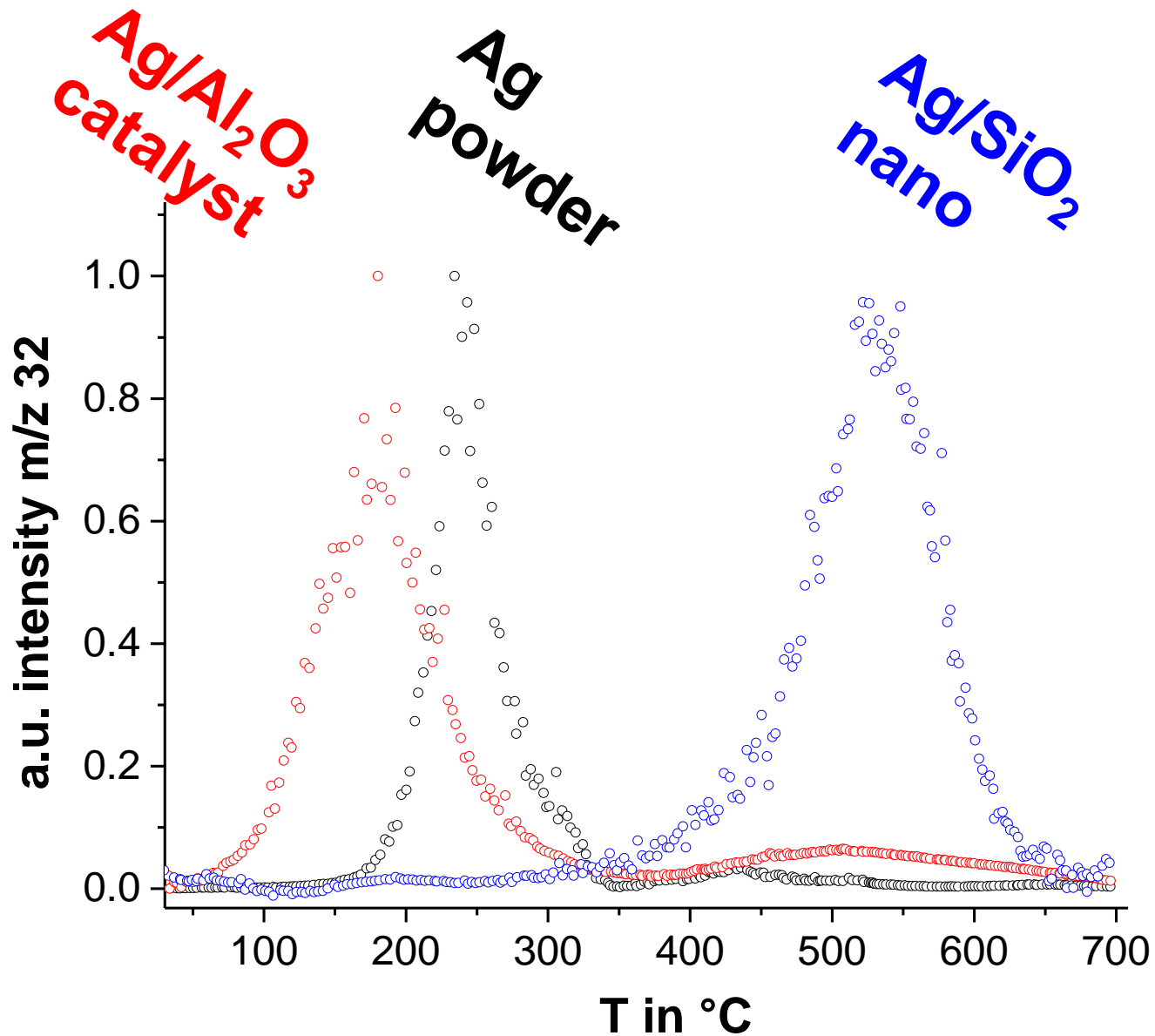

Adapted Polanyi-Wigner Equation

$$\ln\left(\frac{\beta}{T_m^2}\right) = \ln\left(\frac{R A_{des} n_m^{n-1}}{E_{des}} n \Theta_m^{n-1}\right) - \frac{E_{des}}{RT_m}$$

HRV Analysis

(Heating rate variation)

Adapted Polanyi-Wigner Equation

- ⇒ 2nd order desorption
- ⇒ No readsorption or transport limitations

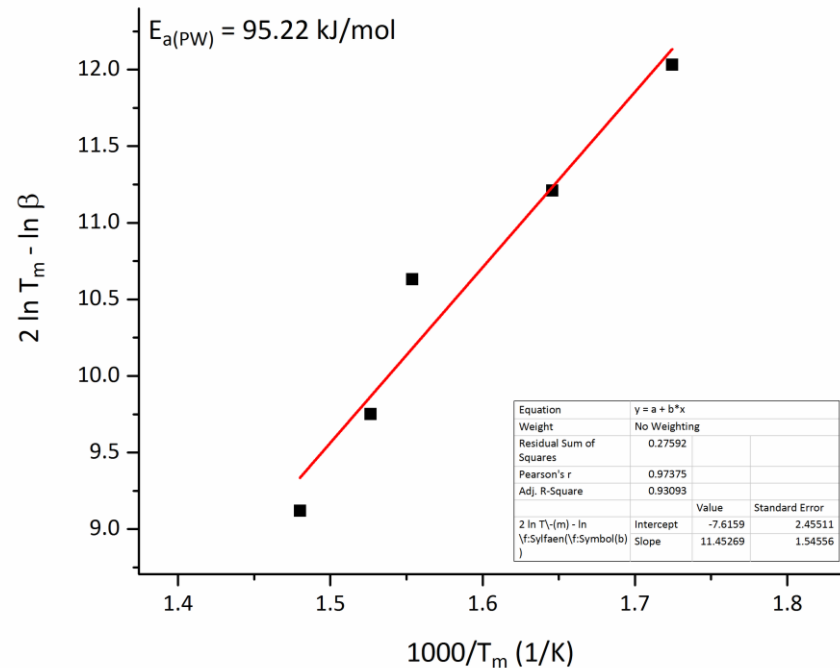
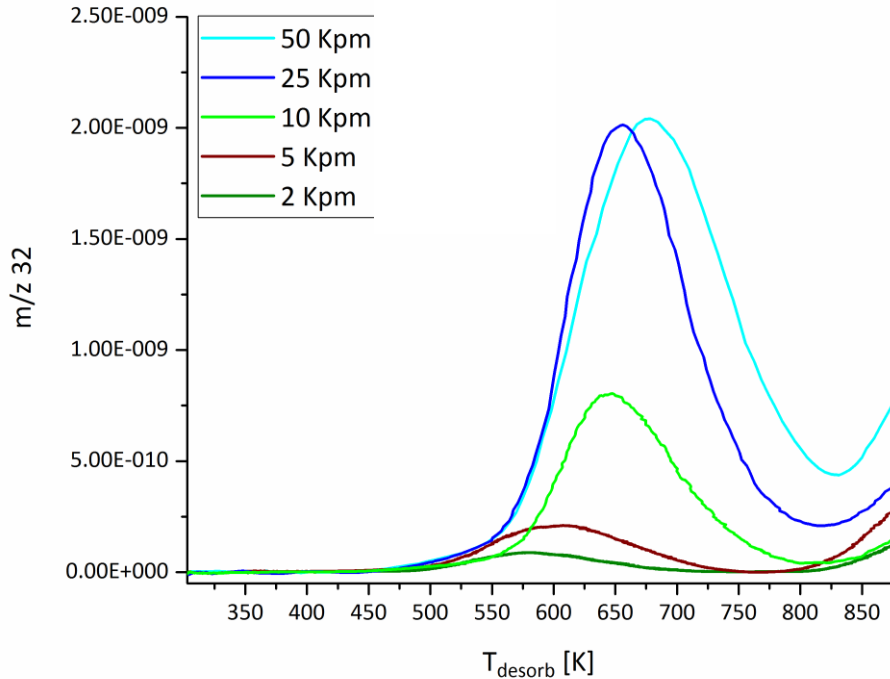

Determination of activation energy for oxygen desorption based on Polanyi-Wigner.

Ag(111): $E_{\text{des}} = 51.9\ \text{kJ/mol}$
 C.T. Campbell, Surf. Sci. 157 (1985) 43.

Summary from previous TDS lectures

“Simple” surfaces:

Suggestive: Number of consecutively adsorbing/desorbing species. BUT!

Qualitatively: Distinction of chemisorbed, physisorbed, condensed species

Quantitative: Evaluation of coverages possible; evaluation of E_d , ν_n and n difficult, many parameters. But still possible.

“Complex” surfaces:

Mostly only qualitative evaluation.

Summary from previous TDS lectures

“Simple” surfaces and “simple model” (Polanyi-Wigner-equation):

Suggestive: Number of consecutively adsorbing species

Qualitatively: Distinction of chemisorbed, physisorbed, condensed species

Quantitative: Evaluation of coverages possible;
evaluation of E_d , ν_n and n difficult,
many parameters

“Complex” surfaces and order-disorder phenomena:

So far only qualitative evaluation or more complex model
with readsorption and diffusion necessary.



See above, quantitative information are extracted!!